

## CITY OF DORAL

### FACADE IMPROVEMENT GRANT AGREEMENT

THIS AGREEMENT is made and entered into this **1st day of July, 2024** (“Effective Date”) by and between the **City of Doral, Florida**, (“City”) and **Doral Office Park LLC**, owner of a property located at **3785 NW 82 Avenue, Doral, FL 33166** whose Federal I.D. No. is **30-1266571** (“Recipient”).

#### RECITALS

WHEREAS, the City is desirous of encouraging activities which contribute to the enhancement of redevelopment activities within the City; and

WHEREAS, the Doral Façade Improvement Grant Program (“Program”) provides financial assistance to businesses, homeowner associations and property owners in the City in order to stimulate private sector investment, beautification, economic growth and job creation in the City by improving the appearance of the buildings within City boundaries; and

WHEREAS, the Program will provide financial assistance by contributing up to 50% of the costs of approved improvements, in an amount not to exceed \$10,000 per project, associated with façade and beautification projects for properties throughout the City limits; and

WHEREAS, pursuant to the Program, **Nicholas Siberio**, as a duly authorized representative of Recipient, applied for a Grant to assist the Recipient in making exterior property improvements to the property located at **3785 NW 82 Avenue, Doral, FL 33166**; and

WHEREAS, after reviewing the application submitted by Recipient, the City has found and determined that it would be beneficial to its economic development and beautification efforts to support Recipient’s improvement project through a grant of funds upon the terms and conditions hereinafter described; and

NOW, THEREFORE, for the mutual considerations described herein and other good and valuable consideration, the parties agree as follows:

#### **D) CITY Obligations and Responsibilities:**

✓ (A) Upon Recipient completing construction of the comprehensive exterior improvements more particularly described in Exhibit “B” (the “Project”), provided the same are deemed acceptable to the City Manager and upon receipt of all documentation relating to the project’s improvement costs, the City shall reimburse Recipient for 50% of the construction cost up to a maximum grant of **\$3,484.63**. In the event that Recipient fails to complete the Project by the Completion Date, as the term is defined in subsection II(F), the City shall not be liable for reimbursement for any construction costs unless the City Manager agrees in writing.

✓ (B) The City shall not be liable for payments for work beyond the scope of the City authorized improvements, nor shall the City be liable for improvements which are made after the Project is completed, or after the City has authorized reimbursement to the Recipient.

- ✓ (C) The City shall not be a party to nor is it liable for any contractual payments to any contractors, architects or other third parties retained by Recipient or associated with the Project. Payments to any of the Recipient's contractors, architects or other parties are the sole responsibility of the Recipient.

**II) Recipient Obligations and Responsibilities:**

- ✓ (A) Recipient acknowledges and agrees that the payment of grant funds by the City shall be paid solely on a reimbursement basis and shall only be for 50% of the construction cost of the Project, up to a maximum grant amount of **\$3,484.63**; and
- ✓ (B) Recipient acknowledges and agrees that the grant funds will be limited to reimbursements for the specific Project approved by the City on the property located at, **3785 NW 82 Avenue, Doral, FL 33166**, as more particularly set forth in Exhibit "B"; and
- ✓ (C) Recipient represents and warrants that it is the owner of the subject property, or if the Recipient is not the owner, it has received the owner's written consent to improve the subject property (letter of consent/authorization is attached hereto as Exhibit "A") and as such it is authorized to contract for exterior property improvements; and
- ✓ (D) If not already provided to the City, the Recipient shall provide to the City a final design sketch of the exterior property improvements along with the selected contractor's bid for the improvements; and
- ✓ (E) In addition to the bid provided in II(D), above, Recipient shall be required to provide at least two additional comparable estimates by licensed contractors. All general exterior property improvements for the Project shall be consistent with all applicable Federal, State and City of Doral codes and design regulations; and
- ✓ (F) Recipient agrees that the Project, as set forth in Exhibit "B," shall be completed by **July 1st, 2025** (the "Completion Date") and no grant fund reimbursement payments shall be made prior to successful completion as determined by the City; and
- ✓ (G) Recipient shall comply with all applicable federal, state, county and municipal laws, ordinances, codes and regulations; and
- ✓ (H) Recipient shall maintain books, records, and documents and adequate internal controls concerning the Project, to sufficiently and properly reflect all expenditures of funds that will be subject to reimbursement by the City under this Agreement; and
- ✓ (I) Recipient shall make all books pertaining to the business and Project available to the City for inspection, review or audit purposes at all reasonable times upon demand the term of this Agreement and for three (3) years thereafter; and
- ✓ (J) The Recipient shall submit to the City not more than sixty (60) days after the Project is completed, all supporting documentation to verify the expenditures for which it seeks reimbursement, including but not limited to paid receipts, two color photographs of the completed exterior property improvements and documentation relating to the construction costs expended for the Project. The sufficiency of the documentation for verification of expenditures is at the City's sole discretion and determination. The

Recipient shall not be provided reimbursement for work performed that is not adequately documented as having been complete and paid; and

- ✓ (K) The Recipient and or the Recipient's contractor(s) shall carry worker's compensation insurance to cover all workers involved in the project. Recipient shall maintain, at its own expense, General Liability Insurance covering the subject property and the resultant uses thereof in the amount of \$1,000,000.00 and will maintain property damage coverage for a minimum of \$100,000.00 the premium of which shall be paid prior to execution of this Agreement. Said insurance shall name the City as an additional insured; and shall provide that the City will receive notice of any cancellation or change in coverage. Recipient shall furnish City with certificates of Insurance. Any lapse of this coverage during this period of the Agreement shall be grounds for termination of the Agreement by the City.

**(III) Representations**

As a material consideration in granting the funds which are the subject of this agreement, the City has relied upon the following representations of the Recipient:

- ✓ (A) Recipient, or any of its officers, directors, or employees has not been convicted of any felony or crime involving dishonesty, fraud, misrepresentation or moral turpitude.
- ✓ (B) To the best knowledge of the Recipient, there is no action, investigation or proceeding pending against the Recipient or any of its officers, directors or employees involving dishonesty, fraud, misrepresentation, moral turpitude or like matters, nor is there any factual basis which is likely to give rise to such an action, investigation or proceeding.
- ✓ (C) The Recipient is a duly authorized representative of the business and is authorized to execute this Agreement.
- ✓ (D) The Recipient shall comply with all applicable laws and procedures in connection with the expenditure of funds including but not limited to obtaining all necessary permits and licenses.

**(IV) Term of Agreement**

- ✓ This Agreement shall commence upon execution and shall expire sixty (60) days after the Completion Date. In the event that the Recipient fails to complete the Project within one (1) year from the Effective Date of this Agreement, City reserves the right to terminate this Agreement upon twenty-four (24) hours' notice to Recipient.

**(V) Designated Representatives**

The names and addresses of the Designated Representatives of the parties in connection with this Agreement are as follows:

**AS TO AGENCY:**                    ✓ **City Manager**  
City of Doral, FL  
8401 NW 53<sup>rd</sup> Terrace  
Doral, FL 33166

**WITH A COPY TO:** **City Attorney** ✓  
City of Doral, FL  
8401 NW 53<sup>rd</sup> Terrace  
Doral, FL 33166

**AS TO RECIPIENT:** **Doral Office Park LLC** ✓  
3625 NW 82nd Avenue, Suite 103  
Doral, FL 33166

**WITH A COPY TO:** \_\_\_\_\_  
\_\_\_\_\_  
\_\_\_\_\_  
\_\_\_\_\_

**(VI) Additional Terms and Conditions**

- (A) Limitation of Liability, Indemnification and Hold Harmless. Recipient acknowledges that the City is not affiliated with or responsible for Recipient's activities hereunder or otherwise. Further, to the fullest extent permitted by law, Recipient shall indemnify and hold harmless the City, its officers and employees, from liabilities, damages, losses and costs, including, but not limited to, reasonable attorneys' fees, to the extent caused by the negligence, recklessness or intentional wrongful misconduct of Recipient and persons employed or utilized by the Recipient in the performance of this Agreement or in relation to the Project. This indemnification shall survive the term of this Agreement.
- (B) Recipient agrees that nothing herein contained is intended or should be construed as in any way creating or establishing the relationship of partners or joint ventures between the City and the Recipient as an agent, representative or employee of the City for any purpose or in any manner whatsoever, and that it shall not represent to any third parties that such is the case.
- (C) Recipient may not assign any rights under this Agreement without the prior written consent of the City, which may be withheld in its sole discretion.
- (D) The name and address of the official payee to whom payments hereunder will be made is:  
  
**Doral Office Park LLC, 3625 NW 82nd Ave, Suite 103, Doral, FL 33166** ✓
- (E) This Agreement shall be governed by the laws of the State of Florida. Any and all legal action necessary to enforce this Agreement will be heard in Miami-Dade County, Florida. No remedy herein conferred upon any part is intended to be in addition to every other remedy given hereunder or now or hereafter existing at law or in equity or by statute or otherwise. No single or partial exercise by any part of any right, power or remedy hereunder shall preclude any other of further exercise thereof.
- (F) This Agreement may only be amended or modified by an instrument in writing signed by both parties.
- ✓ (G) The Recipient acknowledges and agrees that the City may in its sole discretion discontinue this program at any time. At all other times, either party can cancel this Agreement by thirty-(30) days written notice to the other. In the event that Recipient cancels this Agreement, the City shall not be liable to any

contractor (s) or subcontractor (s) with relation to any work performed pursuant to the contract between Recipient and the Contractor(s) or subcontractor(s).

- (H) As a condition of receiving funds under this Agreement, Recipient must agree to keep the façade improvements or Project well maintained, and to refrain from substantial modification of same, for a period of one (1) year. Removal, substantial alteration, or failure to maintain the façade improvements or Project with the specified time frame shall be cause for the City to demand reimbursement of granted funds. Upon demand from the City, the Recipient's failure to repair and/or replace the improvements or to reimburse the granted funds may cause the City to place a lien on the property for the amount of granted funds and administrative fees. The Recipient further agrees to execute, as a condition to this Agreement, a covenant or other instrument in a form prescribed by the City which will be recorded in the Public Records as an encumbrance upon the property for one (1) year from the Project Completion Date.

**(VI) Public Records Law.**

The Recipient shall comply with all applicable requirements contained in the Florida Public Records Law (Chapter 119, Florida Statutes), including but not limited to any applicable provisions in Section 119.0701, Florida Statutes. To the extent that the Recipient and this Agreement are subject to the requirements in Section 119.0701, Florida Statutes, the Recipient shall: (a) keep and maintain public records required by the City to perform the services provided hereunder; (b) upon request from the City's custodian of public records, provide the City with a copy of the requested records or allow public records to be inspected or copied within a reasonable time at a cost that does not exceed the cost provided in Chapter 119, Florida Statutes, or as otherwise provided by law; (c) ensure that public records that are exempt or confidential and exempt from public records disclosure requirements are not disclosed, except as authorized by law for the duration of the term of this Agreement and following completion of this Agreement if the Recipient does not transfer the records to the City; and (d) upon completion of the Agreement, transfer, at no cost, to the City all public records in the possession of the Contractor or keep and maintain public records required by the City to perform the service. If the Recipient transfers all public records to the City upon completion of the Agreement, the Recipient shall destroy any duplicate public records that are exempt or confidential and exempt from public records disclosure requirements. If the Recipient keeps and maintains public records upon completion of the Agreement, the Recipient shall meet all applicable requirements for retaining public records. All records stored electronically must be provided to the City, upon request from the City's custodian of public records, in a format that is compatible with the information technology systems of the City. If the Recipient fails to comply with the requirements in this Section, the City may enforce these provisions in accordance with the terms of this Agreement. If the Recipient fails to provide the public records to the City within a reasonable time, it may be subject to penalties under Section 119.10, Florida Statutes.

**IF THE RECIPIENT HAS QUESTIONS REGARDING THE APPLICATION OF CHAPTER 119, FLORIDA STATUTES, TO THE RECIPIENT'S DUTY TO PROVIDE PUBLIC RECORDS RELATING TO THIS AGREEMENT, CONTACT THE CITY'S CUSTODIAN OF PUBLIC RECORDS AT 305-593-6730, CITYCLERK@CITYOFDORAL.COM, 8401 NW 53RD TERRACE, DORAL, FLORIDA 33166.**

[SIGNATURE PAGE TO FOLLOW]

**IN WITNESS WHEREOF**, the parties have executed this Agreement on the respective dates under each signature. The City, signing by and through its City Manager, attested to by its City Clerk, duly authorized to execute same; and by Recipient by and through its authorized representative, who has been duly authorized to execute same.

ATTEST:

DORAL, FLORIDA



\_\_\_\_\_  
CONNIE DIAZ, CMC  
CITY CLERK



\_\_\_\_\_  
REY VALDES  
CITY MANAGER

Approved as to Form and Legality for  
the Use and Reliance of the City of Doral,  
Florida, only.



\_\_\_\_\_  
GASTESI, LOPEZ & MESTRE, PLLC  
CITY ATTORNEY

AS TO RECIPIENT

ATTEST:

  
\_\_\_\_\_  
SORAYA MELGADO  
CORPORATE SECRETARY

\_\_\_\_\_  
By:   
Signature  
Print Name: Nicholas Siberio  
Title: Property Mgr.

# Facade Improvement Grant Application



Submitted on	30 April 2024, 12:03PM
Receipt number	2
Related form version	6

## Grant Overview

Grant Overview Acknowledgement I acknowledge and accept the terms of the grant program

## Organization Information

Organization Name	DORAL OFFICE PARK, LLC
Federal Employer ID Number (FEIN) number	30-1266571
Florida Corporation Number	M06000000395
Year of Incorporation	01/24/2006
Organization Address	3625 NW 82nd Ave, Doral, FL 33166, USA <a href="#">Map</a> (25.8074977, -80.3287525)

## Document Upload

State of Florida Certificate of Incorporation	<a href="#">Doral Office Park, LLC Sunbiz.pdf</a>
City of Doral Certificate of Use (not required for HOAs or Property Owners)	
City of Doral Local Business Tax Receipt (BTR), or Proof of Non-Profit Status	<a href="#">Doral Office Park, LLC BTR City of Doral.pdf</a>
Signed proof of consent letter from property owner or HOA	<a href="#">Doral Office Park, LLC Letterhead Nicholas Siberio Doral Facade Improvements 4-11-24.pdf</a>
Estimate #1 from Licensed Contractor for proposed property improvements	<a href="#">Advantech Inc. General Contractor Automatic Door Openers Estimate Doral 1 4-16-24.pdf</a>
Estimate #2 from Licensed Contractor for proposed property improvements	<a href="#">Est_5093_from_Oratso_Corporation_11408-1 Doral 1 Automatic Push Door Operator 4-18-24.pdf</a>
Estimate #3 from Licensed Contractor for proposed property improvements	<a href="#">ASSA Abloy Automatic ADA Push Buttons Estimate 4-29-24.pdf</a>

Picture(s) of current facade	<a href="#">IMG_5677.jpg</a>
Conceptual rendering of proposed improvements	<a href="#">swing-door-opener-m-force.jpg.webp</a>
Upload Florida Statutes on Public Entity Crimes Affidavit here	<a href="#">City of Doral Florida Statutes On Public Entity Crimes Signed Notarized Document 4-18-24.pdf</a>

## Indemnity and Hold Harmless Agreement

**Indemnity and Hold Harmless Agreement Acknowledgment** I acknowledge and accept the terms of the Indemnity and Hold Harmless Agreement

## Improvement Project Checklist

Proposed improvements	ADA improvements
Project Narrative	Install an ADA automatic door opener on the lobby entrance into the building. One push button located inside and one push button located outside.
Are the improvements proposed for grant funding part of a larger renovation?	The improvement proposed for grant funding is self-contained.
How will the improvements beautify the surrounding community?	The proposed improvement will make it easier for ADA tenants/visitors to access the building.
Total proposed project cost	\$6,969.26
Total Facade Improvement Grant amount requested	\$3,484.63
Proposed project date	07/01/2024

## Project Budget Form

[Fill Form Online](#)

Item 1	<b>Description</b> STANLEY MAGIC FORCE SINGLE OPERATOR IQ 36"
	<b>\$ Dollar Amount</b> 3980
Item 2	<b>Description</b> TIMER DELAY
	<b>\$ Dollar Amount</b> 48.00
Item 3	<b>Description</b> KIT STANLEY HANDICAPPED PUSH OPENER



**\$ Dollar Amount**  
340.00

**Item 4**

**Description**  
HANDICAPPED MOUNTING POST

**\$ Dollar Amount**  
550.00

**Item 5**

**Description**  
MATERIALS

**\$ Dollar Amount**  
100.00

**Item 6**

**Description**  
LABOR

**\$ Dollar Amount**  
1600.00

Upload Project Budget Form

## Authorized Signer Information

**First Name**

NICHOLAS

**Last Name**

SIBERIO

**Job Title**

PROPERTY MANAGER

**Telephone**

3055926586

**Email**

atriumoffice@aol.com

**Authorized Signer**



[Link to signature](#)



[Department of State](#) / [Division of Corporations](#) / [Search Records](#) / [Search by Entity Name](#) /

## Detail by Entity Name

Foreign Limited Liability Company  
DORAL OFFICE PARK, LLC

### Filing Information

**Document Number** M06000000395  
**FEI/EIN Number** 30-1266571  
**Date Filed** 01/24/2006  
**State** DE  
**Status** ACTIVE

### Principal Address

4649 Ponce de Leon Blvd  
Ste 404  
CORAL GABLES, FL 33146

Changed: 06/08/2023

### Mailing Address

4649 Ponce de Leon Blvd  
Ste 404  
CORAL GABLES, FL 33146

Changed: 06/08/2023

### Registered Agent Name & Address

ARAZOZA & FERNANDEZ-FRAGA, P.A.  
2100 SALZEDO STREET SUITE 300  
CORAL GABLES, FL 33134

### Authorized Person(s) Detail

#### **Name & Address**

Title Manager

Tres Management, LLC  
4649 Ponce de Leon Blvd  
Ste 404  
Coral Gables, FL 33146

### Annual Reports

<b>Report Year</b>	<b>Filed Date</b>
2022	02/24/2022

2023 01/24/2023

2024 02/20/2024

**Document Images**

<a href="#">02/20/2024 -- ANNUAL REPORT</a>	View image in PDF format
<a href="#">01/24/2023 -- ANNUAL REPORT</a>	View image in PDF format
<a href="#">02/24/2022 -- ANNUAL REPORT</a>	View image in PDF format
<a href="#">02/23/2021 -- ANNUAL REPORT</a>	View image in PDF format
<a href="#">03/17/2020 -- ANNUAL REPORT</a>	View image in PDF format
<a href="#">02/19/2019 -- ANNUAL REPORT</a>	View image in PDF format
<a href="#">03/13/2018 -- ANNUAL REPORT</a>	View image in PDF format
<a href="#">03/08/2017 -- ANNUAL REPORT</a>	View image in PDF format
<a href="#">02/24/2016 -- ANNUAL REPORT</a>	View image in PDF format
<a href="#">02/02/2015 -- ANNUAL REPORT</a>	View image in PDF format
<a href="#">02/26/2014 -- ANNUAL REPORT</a>	View image in PDF format
<a href="#">04/16/2013 -- ANNUAL REPORT</a>	View image in PDF format
<a href="#">04/27/2012 -- ANNUAL REPORT</a>	View image in PDF format
<a href="#">02/18/2011 -- ANNUAL REPORT</a>	View image in PDF format
<a href="#">01/13/2010 -- ANNUAL REPORT</a>	View image in PDF format
<a href="#">08/03/2009 -- ADDRESS CHANGE</a>	View image in PDF format
<a href="#">08/03/2009 -- ADDRESS CHANGE</a>	View image in PDF format
<a href="#">01/22/2009 -- ANNUAL REPORT</a>	View image in PDF format
<a href="#">01/04/2008 -- ANNUAL REPORT</a>	View image in PDF format
<a href="#">01/05/2007 -- ANNUAL REPORT</a>	View image in PDF format
<a href="#">01/24/2006 -- Foreign Limited</a>	View image in PDF format



2024

# LOCAL BUSINESS TAX RECEIPT

CITY OF DORAL, FLORIDA  
8401 NW 53RD TERRACE  
DORAL, FL 33166  
(305) 593-6631

**04/16/2024**

**LICENSE NO. BLIC-004477-2024**

**DORAL OFFICE PARK, LLC**

**License Fee Paid: \$200.00**

**3625 NW 82 AVE 103  
Doral, FL 33166**

FOR THE PERIOD COMMENCING OCTOBER 1 AND ENDING SEPTEMBER 30, THE ABOVE-NAMED BUSINESS IS LICENSED TO ENGAGE IN THE FOLLOWING BUSINESS FOR THE LICENSE YEAR:

**Landlord**

**Square Footage:** 57659

**Machines:**

**State License #:**

**No. of Seats/Tables:** 0

**Employees:**

**No. of Units/Spaces:**

**No. of Trucks:**

**CONDITIONS:**

**DORAL: LANDLORD ONLY**

Kenia Palau  
Chief Licensing Official

**This Document Must Be Posted**

## **Doral Office Park, LLC**

*3625 NW 82<sup>nd</sup> Avenue, Suite 103, Doral, FL 33166*

*PH: 305.592.6586 FAX: 305.594.1113*

April 8, 2024

To Whom It May Concern:

I, Nicholas Siberio, representative for Doral Office Park, LLC approve the work to be done to the property, acknowledge and consent of the Facade Grant Application. Thanks.

Any questions please contact me at [atriumoffice@aol.com](mailto:atriumoffice@aol.com) and/or 305-592-6586. Thanks.

Sincerely,



Nicholas Siberio  
Property Manager  
Management Office  
Doral Office Park, LLC

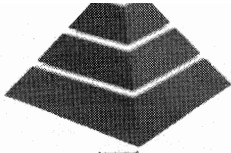

**ADVANTECH INC**  
GENERAL CONTRACTOR

2249 NW 127th Avenue  
Pembroke Pines, FL 33028  
Office: 954-740-9240

**Estimate**

Date	Estimate #
4/12/2024	3659

Fax #	954-740-9240
E-mail	advantech.assistant@gmail.com
Web Site	www.advantechinc.com

**DORAL OFFICE PARK LLC**  
3625 NW 82nd Ave  
Suite 103  
Doral, FL 33166

<b>TERMS</b>
50% IN ADVANCE 50% TO END.
PAYMENT WITH CREDIT CARD APPLY FEE 3.5%

Item #	Description	Qty	Cost	Total
	Doral 1 <b>3785 NW 82 Avenue</b>			
	PARTS:			
4107	STANLEY MAGIC FORCE SINGLE OPERATOR IQ 36"	1	3,980.00	3,980.00T
3762	TIMER RELAY	1	48.00	48.00T
4159	KIT STANLEY HANDICAPPED PUSH OPENER	1	340.00	340.00T
5328	HANDICAPPED MOUNTING POST	1	550.00	550.00T
230	MATERIALS	1	100.00	100.00T
Doors 004 Others	Labor: (2 People)	16	100.00	1,600.00
	- Install 1 new magic operator			
	- Install 1 new timer relay			
	- Install 1 new kit handicapped push opener			
	- Install 1 new handicapped post			
	- Config operation with existing access control.			
	- Install electrical connections to the nearest electrical outlet			
	Note: Permits and fees are not included.			

This estimate is valid for 45 days.

Acceptance of this offer by the customer constitute and order purchase of item and job as describe. Terms: Net 30 days; customer agrees to pay all cost and expenses associated with such enforcement including without limitation, the fee of a collection agency and an attorney.

Advantech Inc reserves the right to retire the equipments installed on invoices over 90 days without required authorization.

Customer agrees to render payment in full for all work performed and agrees to reimburse Advantech Inc. for reasonable attorney fee in the case that payment is not permitted in full. Past due balances subject to service charge of 1.5% per month to any balance owed.

<b>Subtotal</b>	USD 6,618.00
<b>Sales Tax (7.0%)</b>	USD 351.26
<b>Total</b>	USD 6,969.26

Advantech Inc

Customer Signature

\_\_\_\_\_

\_\_\_\_\_

Oratso Corporation

4565 NW 37th Ave  
FL 33142

Phone # 305-888-2211

info@oratsocorp.com

Name/Address

Doral Office Park  
3625 NW 82 AVE (Suite 103)  
Doral, FL 33166

# Estimate

Date	Estimate No.
4/17/2024	5093

Rep	JE
-----	----

Description	Qty	Rate	Total
3785 NW 82nd ave Main Lobby Door			
8100 Series Record Swinging Door Operator	1	2,400.00	2,400.00
36" AL Push long spindle			
BEA Set of Push Plates (Square - Push to Open)	1	450.00	450.00
Buttons with 2 Wireless Transmitter and 1 Receiver.			
Relay RB12-24	1	65.00	65.00
Bollard for push button	1	375.00	375.00
Labor Costs: Time spent by workers to perform work described above.		760.00	760.00
Payment Schedule:			
70% Deposit is Required upon approval of this Estimate.			
30% Due Upon Completion of the specified work.			
Credit Card Convenience / Processing Fees:			
There will be a Credit Card Convenience Fee automatically applied to the Total, at time of payment processing. Fees are as follows:			
Visa / Mastercard / Discover: + 2.5%			
American Express: + 3%			
Thank you for giving us the opportunity to work with you			
		<b>Total</b>	

Signature



Oratso Corporation

4565 NW 37th Ave  
 FL 33142

Phone # 305-888-2211

info@oratsocorp.com

Name/Address

Doral Office Park  
 3625 NW 82 AVE (Suite 103)  
 Doral, FL 33166

# Estimate

Date	Estimate No.
4/17/2024	5093

Rep	JE
-----	----

Description	Qty	Rate	Total
<p>TERMS:                      Quoted prices are valid for 30 days.                      All sales are final and non-disputable, non-refundable,                      and items are non-returnable. Interest of 5% of Invoice                      total, per month, applied on all outstanding invoices.                      All materials remain property of Oratso Corporation                      until Invoice is Paid In Full.</p>			
<p>Thank you for giving us the opportunity to work with you</p>			<p><b>Total</b> \$4,050.00</p>

TERMS: Quoted Prices are valid for 30 days. All charge sales are final and non-disputable.

Signature





# Quotation

**ASSA ABLOY**  
Entrance Systems

Experience a safer  
and more open world

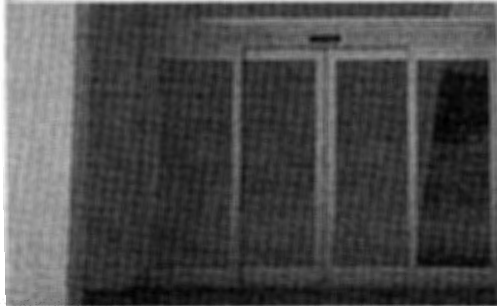

Realbloc, LLC

Doral Office Building Single Swing Door  
Automation

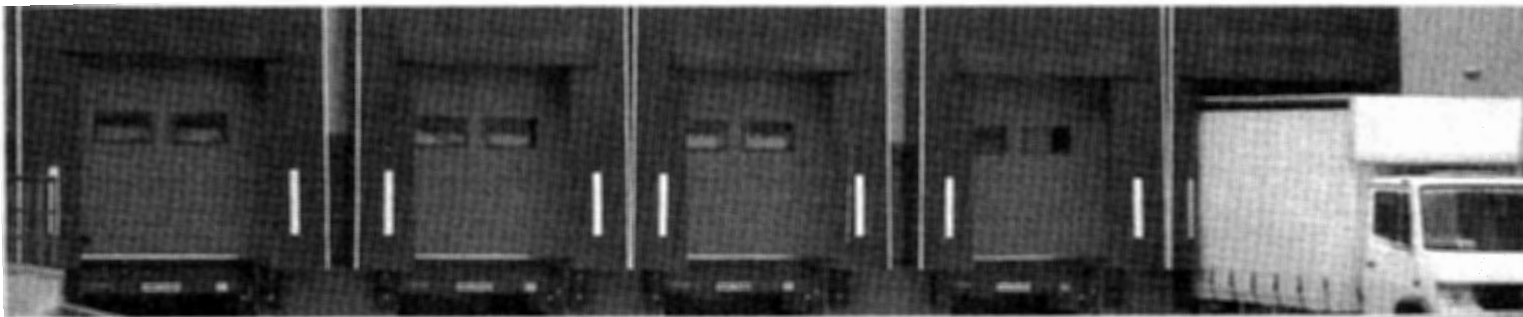

Realbloc, LLC  
Attn: Nicholas Siberio  
3625 NW 82nd Ave  
Doral, FL 33166

## Project Doral Office Building Single Swing Door Automation

\*\*\* For wireless push plates please add \$375\*\*\*

Kind Regards,

Raul Swain  
District Sales Representative  
Raul.Swain@assaabloy.com

ASSA ABLOY Entrance Systems US Inc.  
Crystal Park Building 13  
1937 NW 40th Court  
33064 Pompano Beach  
USA  
Tel: 954-984-0722  
Fax: 954-984-0723

Email:  
[www.assaabloyentrance.us](http://www.assaabloyentrance.us)

**ASSA ABLOY**  
Entrance Systems

Experience a safer  
and more open world

**Solution**

**Single Swing Door Low Energy Automation**

**Qty**

ASSA ABLOY SW200i Swing Door Operator	1
Equipment: Surface Applied	
Handing: Single RH Outswing	
Outswing Reveal: 0" – 3-3/4"	
Cover: 51"	
Sensors Platform: ANSI 156.19	
Finish: Clear Anodized - Class 1	
Arm Finish: Clear	
Configuration : Standard	
<a href="#">Click here for Brochure</a>	
Additional Hardware (per door)	1
4.75" Square Push Plate: Engraved "Push to Open" with "HC Logo"	
Quantity: 2	
Square Surface Box: Surface Box	
Square 4.75"	
Quantity: 2	
Relay:: -	
Decal Kits: Low Energy Decal Kit	
Quantity: 2	
Installation during normal working unless otherwise indicated.	1

**Equipment total : \$4,042.42**

ASSA ABLOY Entrance Systems US Inc.  
Crystal Park Building 13  
1937 NW 40th Court  
33064 Pompano Beach  
USA  
Tel: 954-984-0722  
Fax: 954-984-0723

Email:  
[www.assaabloyentrance.us](http://www.assaabloyentrance.us)

**ASSA ABLOY**  
Entrance Systems

Experience a safer  
and more open world

## Quote Acceptance

**Invoice Address** Realbloc, LLC  
3625 NW 82nd Ave  
Doral, FL 33166

**Site Address** Doral Office Building Single Swing Door  
Automation  
Doral, FL 33166

Quote Summary	Qty
Single Swing Door Low Energy Automation	1

**Equipment total : \$4,042.42**

**Payment Terms:** Pending Credit Approval

**Includes:**

- Installation during normal working hours
- Shop drawings
- Insurance
- Applicable taxes
- (1) SW200i Single Swing Door Operator, Clear Anodized, (2) 4.75" Push Plates w/ Surface Mounting Boxes

**Excludes:**

- 110 volt electrical service to operator header
- Gang Box, 1 pair 18 gauge low voltage wiring, and any necessary conduit or wire mold for each push plate
- Header support for surface mounted swing door operator(s)
- Painting, patching and repairing of floors, walls and ceilings
- Building Permits or Inspections

ASSA ABLOY Entrance Systems US Inc.  
Crystal Park Building 13  
1937 NW 40th Court  
33064 Pompano Beach  
USA  
Tel: 954-984-0722  
Fax: 954-984-0723

Email:  
[www.assaabloyentrance.us](http://www.assaabloyentrance.us)

**ASSA ABLOY**  
Entrance Systems

Experience a safer  
and more open world

**Terms & Conditions: Purchaser's signature on this quotation or issuance of a purchase order or other writing expressing an intention to purchase the services/equipment that is the subject of this quote reflects acceptance of the attached Terms and Conditions.**

**To Ensure Timely Processing, Please Provide Contract/Sub-Contract Documents in MS Word Format.**

**Note: This quote is valid for 30 days. After the expiration date noted above, this quote must be confirmed or adjusted before it can be accepted.**

**Acceptance of Quotation**

Signature of purchaser below represents Purchaser personally (a) has read, understands, and agrees with the terms herein, (b) is holding him or herself out to be authorized to bind his or her company or organization to the terms herein, (c) and that his or her company or organization is of sound financial standing so has to accommodate specifically the payment terms herein expressed.

**Purchaser**

Accepted by: \_\_\_\_\_

Rey Valdes

Print name: \_\_\_\_\_

Date: \_\_\_\_\_

**Purchaser's authorized signature required.**

ASSA ABLOY Entrance Systems US Inc.  
Crystal Park Building 13  
1917 NW 40th Court  
33064 Pompano Beach  
USA  
Tel: 954-984-0722  
Fax: 954-984-0723

Email:  
[www.assaabloyentrance.us](http://www.assaabloyentrance.us)

**ASSA ABLOY**  
Entrance Systems

Experience a safer  
and more open world

## Terms and Conditions

**1. Terms.** Acceptance of this quote by Customer constitutes an order and contract for the purchase of the equipment and/or services described herein. If this quote is not accepted by Customer within 30 days, ASSA ABLOY Entrance Systems US Inc. ("AAES") reserves the right to change the equipment and/or services and prices quoted. Signature on this document or issuance of a purchase order or other writing by Customer expressing an intention to purchase the services/equipment that is the subject of this quote constitutes acceptance of the scope of work and these Terms and Conditions ("Agreement"). Any additional orders, changes or extras for material or labor will be subject to all terms and conditions of this agreement. No terms, provisions, or conditions of any previously or subsequently submitted Customer agreement or purchase order (including but not limited to any verbal representation or understandings) will have any effect on the obligations of the parties under or otherwise modify this Agreement.

**2. Labor.** AAES's labor is non-union and non-prevailing wage unless otherwise stated.

**3. Specific Exclusions.** The following exclusions apply to all work quoted or performed by AAES unless otherwise stated:

- |  |   |
|--|---|
| <ul style="list-style-type: none"> <li>a. Cost of bonds, permits or fees.</li> <li>b. Recertification and/or re-labeling of modified doors or frames.</li> <li>c. Cost of special insurance requirements.</li> <li>d. Engineering, structural support or backing.</li> <li>e. Paint/patch of walls, finish paint/stain, fascia or trim work.</li> <li>f. Protection or cleaning of material after installation.</li> </ul> | <ul style="list-style-type: none"> <li>g. All other items, products or services that are not listed as inclusions</li> <li>h. After-hours security of any type including temporary board up.</li> <li>i. Preparation, installation or connection of material supplied by others.</li> <li>j. All conduits, boxes and wire runs for high or low voltage requirements.</li> <li>k. Interface fire/smoke/security alarm systems.</li> <li>l. Dust and/or security barricades.</li> </ul> |
|--|---|

**4. Submittals.** Submittals, cut sheets and/or shop drawings submitted by AAES and approved by Customer, general contractor, architect or owner shall be deemed the correct interpretation of the scope of work to be performed even if inconsistent with the architectural plans and specifications.

**5. Commencement of Work.** AAES will not commence work by ordering materials or fabrication until:

- a) Customer has signed this Agreement and AAES has countersigned this Agreement;
- b) All complete and current plans, drawings and specifications, if applicable, have been delivered to AAES by Customer;
- c) All submittals, cut sheets and/or shop drawings submitted by AAES have been approved by Customer, general contractor, architect or owner and have been returned to AAES with a stamp of approval;
- d) AAES has received all information from related trades affecting the scope of work being performed;
- e) AAES has received, after Customer's compliance with 5a – 5d, reasonable notice to commence fabrication or ordering of materials within the factory lead time in effect at the time of notice from Customer; and
- f) All credits and debits for changes in quantity or design of material furnished have been accepted in writing.

**6. Delivery.** This quote is subject to AAES's ability to procure suitable material at the time of manufacture. Shipping dates are approximate only and are subject to change. AAES shall not be liable in damages or otherwise for delays or failure in performance when caused by circumstances beyond its reasonable control, including, without limitation, fire, acts of God, strikes, labor difficulties, acts of governmental or military authority, and/or delays in transportation or in procuring materials. In the event that AAES is unable, due to any such occurrence or otherwise, to fulfill its total commitments to all customers, Customer agrees to accept as full and complete performance by AAES, deliveries in accordance with such plan or proration as AAES may adopt. AAES will provide commercial packaging, adequate under normal conditions, to protect the products in shipment and identify the contents. Should Customer request any special packaging, it will be done at Customer's expense. All products will be shipped via the most cost effective means of transportation under the circumstances, unless Customer indicates otherwise. In the event Customer requests expedited shipping and handling, AAES shall comply provided Customer pays all reasonable expediting and increased shipping fees and expenses. If Customer provides no routing instructions, AAES shall be the sole judge of the best method of routing shipment. Claims for loss or damage in transit must be entered and prosecuted by the Customer. AAES will provide reasonable assistance, at Customer's expense, upon request.

**7. Storage.** If after complete or partial fabrication of the equipment purchased by Customer, shipment of the equipment is delayed at the request of Customer for 30 calendar days past the agreed upon delivery date, Customer will be invoiced for the equipment based on the agreed upon delivery date and will pay the invoice upon the terms thereof. AAES will store the equipment at its or a third party's facility and, as necessary, insure the equipment and arrange for shipment, at Customer's expense.

**8. Installation Requirements.** Unless otherwise stated, Customer must comply with the following requirements:

- a) 110-volt AC permanent power must be available to each of the automatic operators at the time of installation. Additional charges will be added in the event it is not.
- b) If the project contains multiple units, Customer must provide AAES with the ability to complete the work in a manner that allows for the continuous installation of multiple units without interruption, delay or return trips to the project site. If the work cannot be completed as set forth herein, Customer shall incur additional charges.
- c) Once given an authorization to proceed, Customer must properly prepare the area for the automatic door equipment. If the installers arrive and find that the area is not properly prepared to accept the equipment for installation, Customer shall incur additional charges for loss of time for the crew, travel and staging.
- d) Once given an authorization to proceed, Customer must ensure that the area is accessible and free of other trades working above, below or adjacent to AAES' equipment. If the installers arrive and find that other trades might impede our ability to install in the area, Customer shall incur additional charges for loss of time for the crew, travel and staging.
- e) All work shall be performed during normal business hours: Monday through Friday, 8:00 a.m. – 4:00 p.m.

**9. Back-charges.** No back-charges will be accepted unless approved in writing by AAES.

**10. Cancellation.** All orders shall be subject to cancellation fees to cover any and all administrative fees and restocking fees. If materials have been ordered and Customer cancels the order, Customer shall pay for all materials released for fabrication in addition to all administrative and restocking fees. If no materials have been ordered, Customer shall pay 20% of the overall order.

**11. Payment.** 50% deposit or joint check agreements are required for new customers that are denied credit or special orders. Payment terms are net 30 days from invoice date. If payment is not received within 30 days, a finance charge of 1½ % per month will be assessed and added to past due invoices. If Customer defaults in payment obligations with respect to equipment, AAES has the right to suspend fabrication or cancel any outstanding orders. If Customer defaults in payment obligations with respect to services, AAES has the right to file a lien against all or part of the property being improved. Should payment be received in the form of a check containing insufficient funds, a charge of \$25.00 will be added for each additional deposit attempt. In the event AAES has to enforce its right to payment under this Agreement, Customer agrees to reimburse AAES for any costs reasonably incurred by AAES relating to Customer's default (e.g., costs of collection, attorneys' fees, and court costs).

**12. Shipment and Risk of Loss.** Title, ownership and risk of loss of product(s) purchased by Customer ("Purchased Product") shall pass from AAES to Customer upon shipment of Purchased Product from AAES's factory. AAES reserves the right to invoice Customer for 50% of the contract upon shipment of Purchased Product from the AAES factory.

**13. Limited Warranty.** There are no guarantees or warranties except those specifically set forth herein. New equipment shall be free from material defects for a period of one (1) year from the date of installation. Extended warranties are available for an additional charge. Warranty does not apply when damage is caused by misuse, fire, flood, storms, vandalism, acts of God, or any other cause outside of AAES's control. No allowance or credit will be made or given for any warranty material or labor repairs made by AAES. **In the event (i) it is discovered that the equipment has been tampered with or (ii) if work has been performed on the equipment by any person or company other than AAES, this paragraph and all warranties and indemnification obligations of AAES set forth herein shall be void.** AAES reserves the right to refuse to perform warranty service if Customer has not complied with all payment obligations under the Agreement. Warranty services shall be performed during normal business hours, Monday – Friday, 8:00 a.m. – 4:00 p.m. In the event after-hours, weekend or holiday warranty service is required, over-time or double-time labor and zone charges will apply and will be invoiced at the then-current AAES labor rates. **ALL OTHER WARRANTIES, EXPRESS OR IMPLIED, INCLUDING ANY WARRANTIES OF MERCHANTABILITY AND FITNESS FOR A PARTICULAR USE ARE HEREBY DISCLAIMED. THE FOREGOING EXPRESSES ALL OF SUBCONTRACTOR'S OBLIGATIONS AND LIABILITIES WITH RESPECT TO THE PRODUCTS FURNISHED BY IT HEREUNDER.**

**14. Insurance.** AAES's obligation to maintain insurance shall be limited to the types and amounts of coverage set forth on the certificate of insurance submitted by AAES.

**15. LIMITATION OF LIABILITY.** AAES shall not be liable for any indirect, incidental or consequential damages (including without limitation, lost profits or savings), arising from or related to the sale of equipment or any related installation or maintenance services, even if such damages are foreseeable or AAES had notice of such damages. If AAES breaches any of its obligations, Customer's sole and exclusive remedy, and AAES's entire liability, shall be the re-performance of AAES's applicable warranty obligations set forth above with respect to the purchased equipment and the re-performance of any non-conforming services with respect to any installation or maintenance services purchased by Customer. The total liability of AAES related to or arising out of this quote shall not exceed the amount paid by Customer to AAES hereunder. This limitation of liability will apply even if AAES's re-performance of any obligation fails of its essential purpose. This limitation of liability reflects a negotiated allocation of risks between the parties and is an essential part of the consideration for AAES's performance of the Agreement.

# ASSA ABLOY Entrance Systems

## Opening doors to business and life

ASSA ABLOY Entrance Systems' comprehensive range of entrance automation products and solutions supports efficient and reliable entrance operation throughout any facility.

### Complete entrance solutions for every building

- Automatic doors
- Industrial & commercial doors
- High-performance doors
- Hangar doors
- Loading dock equipment
- Service

*Our team of experienced specialists offers support and advice throughout the whole building process.*



# Swing Door

## ASSA ABLOY SW200i™ Surface Mounted Operator

ASSA ABLOY

ASSA ABLOY Entrance Systems

The global leader in door opening solutions

### Technical Data Sheet

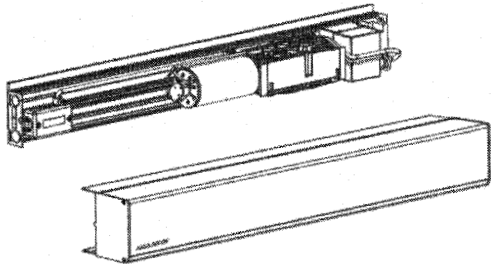

#### SW200i Surface Mounted Swing Door Operator

The ASSA ABLOY SW200i automatic swing operator is intended for use in exterior or interior entryways, corridors and a variety of applications. The ASSA ABLOY SW200i heavy duty (HD) electro-mechanical operator is suitable for use on large heavy doors, yet adaptable enough to be used in low energy (LE) applications. The product can be either surface mounted or overhead concealed, on either side of the door, for pull or push applications. It is suitable for single doors, double doors and double egress doors fitted with swing clear hinges, offset pivots or center pivots. The operator is connected to the door leaf with a range of different arm systems.

ASSA ABLOY SW200i is designed to offer continuous use, a high degree of safety and maximum performance over the lifetime of your entrance. The ASSA ABLOY SW200i ensures all-around safety and can be equipped with a full range of sensor products providing swing door safety that meets or exceeds ANSI A156.10 standard.

#### Operator Features and Performance

- Operator: electro-mechanical, non-handed operator, 24 volt, 5/16 hp motor
- ANSI Compliance: Field selectable full pedestrian usage (ANSI A156.10) and low energy (ANSI A156.19)
- Door Weight: up to 700 pounds (315 kg) per operator
- Door Size: up to 48" (consult for wider sizes)
- Manual Push Force: adjustable from 5 lbf – 15 lbf
- Hold Open Time: adjustable from 1.5 seconds to 30 seconds
- Wind Force Dampening: operator mechanically counteracts to wind forces, slowing down the opening or closing of the door
- Stack Pressure Compensation: operator counteracts to positive stack pressures, negative stack pressures, and sudden changes of stack pressures to maintain consistent door speeds
- Intelligent Trajectory Control: operator knows where the door should be at all times and adjusts torque accordingly. Dynamic braking helps cushion the door during opening to prevent going past 90 degrees, or during closing to prevent slamming.
- Extended Closing Torque (ECT): exclusive Extended Closing Torque (ECT) functionality provides extra torque in the last 10 degrees of closing, if needed, to close and latch the door. Speed remains constant so the door stays within ANSI standards.



- Latch Retry: if the door does not latch when closing, the SW200i will detect this condition and immediately open the door to 10 degrees and execute two attempts to latch the door.
- On-board timing sequencer
- On-board 12V or 24V transformer
- Low pass filter (i.e. "delay on make")
- Door position relay
- Kill input to close doors immediately
- Self-learning set-up – measures inertia and door weight
- Low Power Consumption (300 watts, 2.5 amp (max))

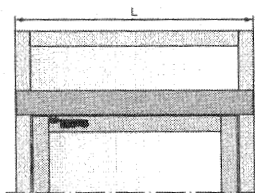

Door Set-ups:

Left: Single

Below Left: Dual Egress

Below Right: Simultaneous Pair

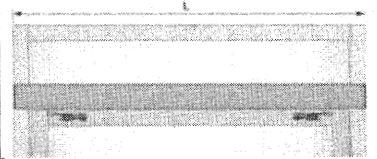
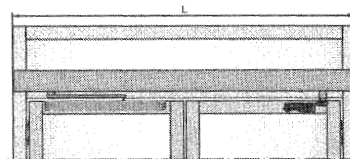



- Automatic sensor activation (ANSI A156.10)
- Push plate activation (ANSI A156.19 or A156.10)
- Push and go feature allowing door to open automatically when operator senses movement of door (ANSI A156.19)
- Power assist open – provides easy to open push forces (ANSI A156.19)
- Internal, push to open, push to close (i.e., ratchet relay) (ANSI A156.19)
- Speed controlled Extended Closing Torque (ECT) to provide power assist close with on-board functionality to automatically adjust torque without increasing speed
- Loss of Power: the operator controls the door closing, preventing slamming of door
- Torque Limiting: if positive air pressure condition is removed, operator compensates accordingly and will not slam



**Door Operator Handings**

**Electric Lock Management**

- Lock monitoring prevents operator(s) from opening door(s) until release of electrified lock
- Operator pulls door closed before opening, unjamming electric latch hardware
- Sequenced operation between operators for pairs of doors allowing lock release and astragal coordination
- Electric Lock Output: selectable 12 VDC, maximum 1200 mA / 24 VDC, maximum 600 mA

**Sensor Monitoring**

- Monitored Door Mounted Presence Sensors – upon detection of sensor failure, the operator will automatically revert to low energy mode
- Blanking Potentiometer: tells sensors on swing side of door when to shut off
- Torque Cancellation – Extended Closing Torque (ECT) is deactivated if signal is received from door mounted presence sensors of a possible obstruction

**Aesthetics**

- Aesthetically pleasing, low profile appearance: 4-5/16" (109mm) high by 5-1/8" (130mm) deep
- Continuous header for full width of door
- Same header/housing as ASSA ABLOY PowerSwing and ASSA ABLOY SW100 for consistent sightlines in your facility
- Finishes: anodized, powder coat, Kynar, clad

**Configurations**

- Surface Applied • Side Load • Bottom Load

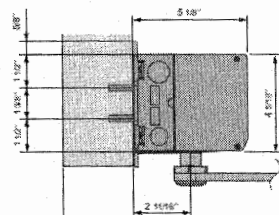
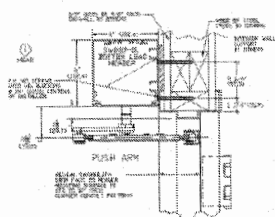

**Authorities**

- UL/CUL approved
- UL Listed Fire Door Operator
- UL10C, UL325, UL991, UL244A, UL1998, UL1310
- IBC and CBC
- ANSI A156.10 / ANSI A156.19
- CAN/CSA-C22.2 NO 223-M91 and CAN/CSA-C22.2 NO 223-M92
- California State Fire Marshall

**Sensor Packages**

- Sensor Packages as follows:
  - ANSI A156.19**
    - Activation: push plates per your selection
    - Safety devices: not required per ANSI. Optional door mounted presence sensors (DMPS) are available

**ANSI A156.10**

- Activation: push plates per your selection (motion sensors or push plates)
- Choice of ASSA ABLOY i-Adapt™ door mounted presence sensor system:
  - A202 – ASSA ABLOY i-Adapt Premium – stand alone, adapted field, door mounted presence sensors (DMPS)
  - A102 – ASSA ABLOY i-Adapt Flex – overhead presence sensor (OPS) and one door mounted presence sensor (DMPS) per swing and non-swing side
  - A101 – ASSA ABLOY i-Adapt Flex - overhead presence sensor (OPS) and one door mounted presence sensor (DMPS) swing side
  - A100 – ASSA ABLOY i-Adapt Flex – Knowing Act applications – dual egress only – overhead presence sensor (OPS) and motion sensor secondary activation per ANSI A156.10

**Authorities**

<b>Operator type</b>	Electro-mechanical
<b>Door width</b>	36" – 48" (914 – 1219mm)
<b>Door weight</b>	100 – 700 lb (45 – 315 kg)
<b>Power supply</b>	120 V AC +10/-15%, 50/60 hz
<b>Power consumption</b>	Max. 300W
<b>Auxiliary voltage</b>	24 V DC, max. 700 mA
<b>Internal control fuse</b>	2 x T 6, 3 AH 250 V
<b>Electro-mechanical locking device</b>	Selectable: 12V DC, max. 1200 mA / 24 V DC, max. 600 mA
<b>Door opening</b>	<b>Push:</b> 80 – 110° with reveal 0 – 12" (0 – 305mm) <b>Pull:</b> 80 – 110° with reveal 0 – 5-1/8" (0 – 130mm) <b>PAS:</b> 80 – 95° (concealed application)
<b>Opening time (0 – 80°)</b>	Variable between 2 – 12 seconds
<b>Closing time (90 – 100°)</b>	Variable between 4 – 12 seconds
<b>Hold open time</b>	1.5-30 seconds
<b>Ambient temperature</b>	-31° F to 160° F (-35° C to 71° C)
<b>Relative humidity</b>	Max. 85%
<b>Drive weight unit (non-condensing)</b>	19.8 lb (9 kg)
This product is to be installed internally or externally with suitable weather protection.	
<b>Class of protection</b>	IP 20.
<b>Complies with:</b> ANSI/BHMA A156.19, ANSI/BHMA A156.10, UL325, UL 991, UL 244A, UL 1998, UL 1310, UL 10C, CAN/CSA-C22.2 NO 223-M91, CAN/CSA-C22.2 NO 247-92 and CA State Fire Marshall	

ASSA ABLOY Entrance Systems  
 Tel: 1-866-237-2687 (US) • 1-888-608-9242 (Canada)  
 info-automatic.na.entrance@assaabloy.com  
 assaabloyentrance.us • assaabloyentrance.ca

ASSA ABLOY as words and logo are trademarks owned by the ASSA ABLOY Group.

Technical data subject to change without notice. ©ASSA ABLOY Entrance Systems AB/IT/DS SW2001; CAN-USA-EN-3.0/2012

## 1 Description

BEA introduces its new stainless steel pushplate line. These pushplates are designed to fit into standard electrical gang boxes, and/or BEA's line of plastic enclosures. The faceplate is made of 1/16" thick stainless steel for durability, and has concealed fasteners to minimize vandalism. The pushplates may be hard wired to the door operator or connected to BEA's line of radio-controlled transmitters.

**NOTE:** if using transmitters, BEA recommends not using metal electrical boxes as this will reduce the range or effectiveness of the transmitters radio signal.

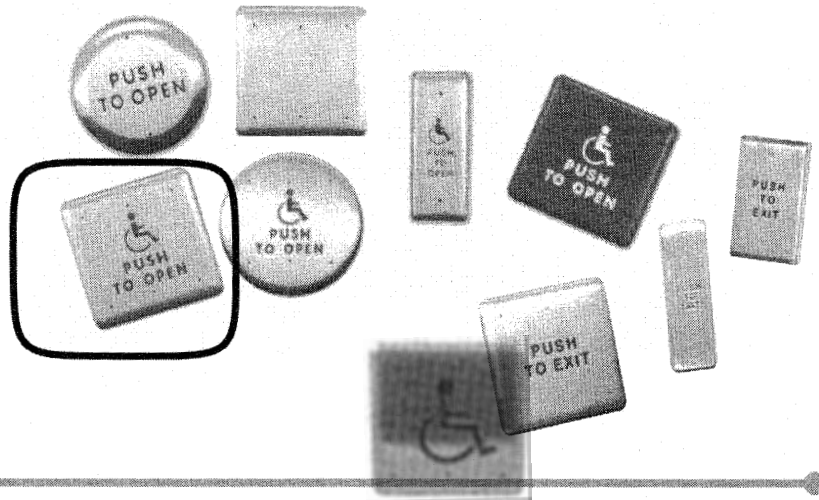

## 2 Specifications

DESCRIPTION	4.5" ROUND	6" ROUND	4.75" SQUARE	6" SQUARE	JAMB	SINGLE GANG
SIZE	4.50" X 0.62"	6.00" X 0.62"	4.75" X 0.62"	6.00" X 0.62"	1.50" X 4.75" X 0.62"	2.75" X 4.50" X 0.40"
<b>PUSH TO OPEN</b>	10PBR45	10PBR	<b>10PBS</b>	10PBS6	10PBJ	
TEXT AND LOGO	10PBR451	10PBR1	10PBS1	10PBS61	10PBJ1	10PBO241
LOGO ONLY	10PBR45LL	10PBRLL	10PBSLL	10PBS6L	10PBJL	10PBO24L
PLAIN FACE	10PBR4510	10PBR10	10PBS10	10PBS610	10PBJ10	
WHITE ON BLUE			10PBS1B			
PUSH TO EXIT			10PBSE		10PBJE	10PBO24E

## 3 Precautions

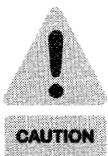

- Shut off all power before attempting any wiring procedures.
- Maintain a clean & safe environment when working in public areas.
- Constantly be aware of pedestrian traffic around the door area.
- Always stop pedestrian traffic through doorway when performing tests that may result in unexpected reactions by door.
- ESD electrostatic discharge: Circuit boards are vulnerable to damage by electrostatic discharge. Before handling any board ensure you dissipate your body's charge.
- Always check placement of all wiring before powering up to insure that moving door parts will not catch any wires and cause damage to equipment.
- Ensure compliance with all applicable safety standards (i.e. ANSI A156.10/19) upon completion of installation.
- DO NOT** attempt any internal repair of the sensor. All repairs and/or component replacements must be performed by BEA, Inc. Unauthorized disassembly or repair:
  1. May jeopardize personal safety and may expose one to the risk of electrical shock.
  2. May adversely affect the safe and reliable performance of the product will result in a voided product warranty.

## 4 Accessories

CUSTOM PUSHPLATE - Etched Pushplate with Company Name and/or Logo.

PLASTIC ENCLOSURES - Wide Range of Surface and Flush Mount Electrical Boxes.

TRANSMITTERS & RECEIVERS - Range of Analog and Digital Transmitters and Receivers.

BOLLARD - Steel Pushplate Mounting Post Available in Black, Bronze and Silver for use with 4 1/2" Round & 4 3/4" Square Pushplates.

ESCUTCHEON - Stylish Stainless Steel Surface Mounting Box for 4.5" & 6" Round Pushplates.

## 5 Installation

1. Wire the pushplate to the door controller or radio controlled transmitter using the NO or NC and COM contacts.

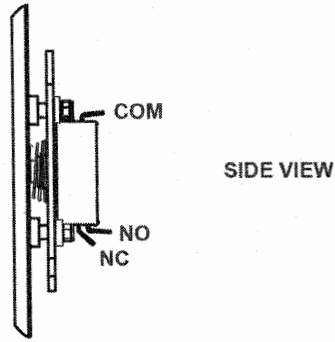

2. Finger-tighten the enclosed hex-head screws into the electrical enclosure.

**NOTE:** The 6" Round, 6" & 4 3/4" Square pushplates contain two different sized screws. The larger screws (#8) are for the corner locations on 4X4 electrical type boxes and the two smaller screws (#6) are for the single-gang or double-gang electrical type boxes.

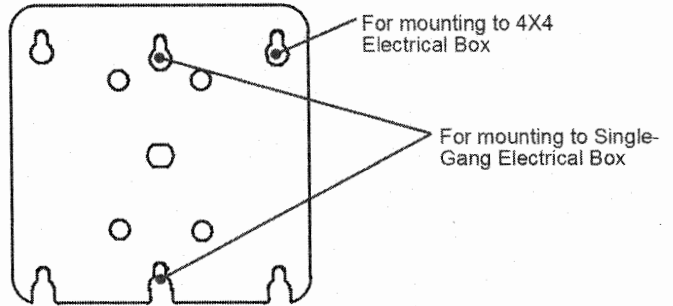

3. Place the pushplate holes over the hex-head screws. Use the enclosed hex key to fully tighten the screws.

4. Test for proper pushplate activation.

**NOTE:** Pushplates will need an Adapter Ring (10BRINGC) to use with BEA's Double Gang Electrical Box.

## 6 Cleaning

The pushplates are constructed with durable stainless steel and painted with scuff-resistant coatings. To clean the plates, use only a damp, non-abrasive cloth. Regular cleaning with harsh solvents or abrasive materials may cause deterioration of the paint coating. Please make the end-user aware of this procedure.

## 7 Company Contact



Do not leave problems unresolved. If a satisfactory solution cannot be achieved after troubleshooting a problem, please call BEA, Inc. If you must wait for the following workday to call BEA, leave the door inoperable until satisfactory repairs can be made. Never sacrifice the safe operation of the automatic door or gate for an incomplete solution.

Our Service Technicians can be called 24 hours a day, 7 days a week. For more information visit [www.beasensors.com](http://www.beasensors.com).

Northeast US & Canada: 1 866.836.1863  
Mountain & West: 1 888.419.2564

Southeast: 1 800.407.4545  
Regional: 1 866.249.7937

Midwest: 1 888.308.8843



Management Office  
302-202-6280  
No Soliciting





FLORIDA STATUTES ON PUBLIC ENTITY CRIMES

**THIS FORM MUST BE SIGNED AND SWORN TO IN THE PRESENCE OF A NOTARY PUBLIC OR OTHER OFFICIAL AUTHORIZED TO ADMINISTER OATHS**

1. This form statement is submitted to Miami-Dade County  
by Nicholas Siberio Property Manager (Print individual's name and title)  
for Doral Office Park LLC (Print name of business submitting sworn statement)  
whose business address is: 3625 NW 82 Ave (Address, City, State, Zip Code) Suite 103 Doral FL 33166  
and if applicable its Federal Employer Identification Number (FEIN) is 30-1266571  
If the entity has no FEIN, include the Social Security Number of the individual signing this sworn statement.

2. I understand that a "public entity crime" as defined in paragraph 287.133(1)(g), Florida Statutes, means a violation of any state or federal law by a person with respect to an directly related to the transactions of business with any public entity or with an agency or political subdivision of any other state or with the United States, including, but not limited to any bid or contract for goods or services to be provided to public entity or agency or political subdivision of any other conspiracy, or material misinterpretation.

3. I understand that "convicted" or "conviction" as defined in Paragraph 287.133(1)(b), Florida Statutes, means a finding of guilt or a conviction of a public entity crime, with or without an adjudication of guilt, in an federal or state trial court of record relating to charges brought by indictment or information after July 1, 1989, as a result of a jury verdict, non-jury trial, or entry of a plea of guilty or nolo contendere.

4. I understand that an "Affiliate" as defined in paragraph 287.133(1)(a), Florida Statutes, means:

1. A predecessor or successor of a person convicted of a public entity crime, or
2. An entity under the control of any natural person who is active in the management of the entity and who has been convicted of a public entity crime. The term 'affiliate" includes those officers, directors, executives, partners, shareholders, employees, members, and agents who are active in the management of an affiliate. The ownership by one person of shares constituting a controlling interest in another person, or a pooling of equipment or income among persons when not for fair market value under an arm's length agreement, shall be prima facie case that one person controls another person. A person who knowingly enters into a joint venture with a person who has been convicted of a public entity crime Florida during the preceding 36 months shall be considered an affiliate.

5. I understand that a "person" as defined in Paragraph 287.133(1)(e), Florida Statutes, means any natural person or entity organized under the laws of any state or of the United States within the legal power to enter into a binding contract and which bids or applies to bid on contracts of the provision of goods or entity. The term "person" includes those executives, partners, shareholders, employees, members, and agents who are active in management of an entity.



6. Based on information and belief, the statement which I have marked below is true in relation to the entity submitting this sworn statement. (Please indicate which statement applies.)

Neither the entity submitting sworn statement, nor any of its officers, director, executives, partners, shareholders, employees, members, or agents who are active in the management of the entity, nor any affiliate of the entity has been charged with and convicted of a public entity crime subsequent to July 1, 1989.

The entity submitting this sworn statement, or one or more of its officers, directors, executives, partners, shareholders, employees, members, or agents who are active in the management of the entity, or any affiliate of the entity had been charged with and convicted of a public entity crime subsequent to July 1, 1989, AND (please indicate which additional statement applies.)

The entity submitting this sworn statement, or one or more of its officers, directors, executives, partners, shareholders, employees, members, or agents who are active in the management of the entity, nor any affiliate of the entity has been charged with and convicted of a public entity crime subsequent proceeding before a Hearing Officer of the State of the State of Florida, Division of Administrative Hearings and the Final Order entered by the Hearing Officer determined that it was not in the public interest to place the entity submitting this sworn statement on the convicted vendor list. Attach a copy of the final order.

I UNDERSTAND THAT THE SUBMISSION OF THIS FORM TO THE CONTRACTING OFFICER FOR THE PUBLIC ENTITY IDENTIFIED I PARAGRAPH 1(ONE) ABOVE IS FOR THAT PUBLIC ENTITY ONLY AND THAT THIS FORM IS VALID THROUGH DECEMBER 31 OR THE CALENDAR YEAR IN WHICH IT IS FILED. I ALSO UNDERSTAND THAT I AM REQUIRED TO INFORM THAT PUBLIC ENTITY PRIOR TO ENTERING INTO A CONTRACT IN EXCESS OF THE THRESHOLD AMOUNT PROVIDED IN SECTION 28.017 FLORIDA STATUTES FOR A CATEGORY TWO OF ANY CHANGE IN THE INFORMATION CONTAINED IN THIS FORM.

*[Handwritten Signature]*  
\_\_\_\_\_  
(Signature)

Sworn to and subscribed before me this 18 day of April, 2024.

Personally Known Nicholas Siberio

Or produced identification \_\_\_\_\_ Notary Public-State of FLORIDA

Grisel Berdion My commission expires (Printed, typed or stamped commissioned name of notary public)

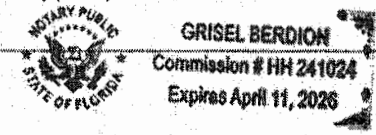

**RESOLUTION No. 24-141**

**A RESOLUTION OF THE MAYOR AND THE CITY COUNCIL OF THE CITY OF DORAL, FLORIDA, APPROVING THE AWARD OF FISCAL YEAR 2024 CYCLE FAÇADE IMPROVEMENT GRANTS IN THE AMOUNT OF \$10,000.00 TO AMERICAS 7910 LLC; \$10,000.00 TO DORAL ESTATES HOMEOWNERS' ASSOCIATION INC; \$3,484.63 TO DORAL OFFICE PARK LLC; \$10,000.00 TO SANTORINI AT ISLANDS AT DORAL NEIGHBORHOOD ASSOCIATION INC; AND \$7,732.50 TO THE VILLAGE OF DORAL DUNES ASSOCIATION INC; AND PROVIDING FOR AN EFFECTIVE DATE**

**WHEREAS**, the City of Doral (the "City") provides financial assistance to businesses, commercial property owners and homeowners associations in Doral through the Façade Improvement Grant in order to stimulate private sector investment, advance economic growth and encourage the beautification of buildings and communities within Doral; and

**WHEREAS**, the City received five (5) eligible applications in response to the FY24 Cycle of Façade Improvement Grant Applications by May 10th, 2024; and

**WHEREAS**, after careful review of the applications, the Façade Improvement Grant Evaluation Committee respectfully recommends that the Mayor and City Council approve Façade Improvement Grant awards to each of the following organizations:

1. Americas 7910 LLC - \$10,000.00
2. Doral Estates Homeowners Association Inc - \$10,000.00
3. Doral Office Park LLC - \$3,484.63
4. Santorini at Islands at Doral Neighborhood Association Inc - \$10,000.00
5. The Village of Doral Dunes Association Inc - \$7,732.50

**WHEREAS**, the Mayor and City Council believe that these Façade Improvement Grant awards will advance economic development and quality of life and otherwise be in



the best interests of the City.

**NOW, THEREFORE, BE IT RESOLVED BY THE MAYOR AND THE CITY COUNCIL OF THE CITY OF DORAL, FLORIDA, AS FOLLOWS:**

**Section 1. Recitals.** The foregoing recitals are confirmed, adopted, and incorporated herein and made a part hereof by this reference.

**Section 2. Approval.** The Mayor and City Council, hereby approve a Façade Improvement Grant award of \$10,000.00 to Americas 7910 LLC, \$10,000.00 to Doral Estates Homeowners Association Inc, \$3,484.63 to Doral Office Park LLC, \$10,000.00 to Santorini at Islands at Doral Neighborhood Association Inc, and \$7,732.50 to The Village of Doral Dunes Association Inc.

**Section 3. Implementation.** The City Manager and City Attorney are hereby authorized to take such additional action as may be necessary to implement the purpose and provision of this Resolution.

**Section 4. Effective Date.** This Resolution shall become effective upon its adoption.

The foregoing Resolution was offered by Vice Mayor Puig-Corve who moved its adoption.

The motion was seconded by Councilmember Pineyro and upon being put to a vote, the

vote was as follows:

Mayor Christi Fraga	Yes
Vice Mayor Oscar Puig-Corve	Yes
Councilwoman Digna Cabral	Yes
Councilman Rafael Pineyro	Yes
Councilwoman Maureen Porras	Yes

PASSED AND ADOPTED this 12 day of June, 2024.

CHRISTI FRAGA, MAYOR

ATTEST:

CONNIE DIAZ, MMC  
CITY CLERK

APPROVED AS TO FORM AND LEGAL SUFFICIENCY  
FOR THE USE AND RELIANCE OF THE CITY OF DORAL ONLY:

GASTESI, LOPEZ & MESTRE, PLLC  
CITY ATTORNEY