

RESOLUTION NO. 21-219

A RESOLUTION OF THE MAYOR AND THE CITY COUNCIL OF THE CITY OF DORAL, FLORIDA, PURSUANT TO SECTION 2-322 OF THE CITY'S CODE OF ORDINANCES, AUTHORIZING THE CITY MANAGER TO UTILIZE THE AGREEMENT WITH AXON ENTERPRISE, INC. FOR THE PURCHASE OF ELEVEN (11) BODY WORN CAMERAS AND RELATED LICENSES AND ACCESSORIES FOR THE USE OF THE CODE COMPLIANCE DEPARTMENT IN AN AMOUNT NOT TO EXCEED BUDGETED FUNDS VIA CONTRACT No. 151089 CITY OF TUCSON, ARIZONA; AUTHORIZING THE CITY MANAGER TO EXPEND FUNDS ON BEHALF OF THE CITY; PROVIDING FOR IMPLEMENTATION; AND PROVIDING FOR AN EFFECTIVE DATE

WHEREAS, the Code Compliance Department ("Department") for the City of Doral (the "City") is seeking to purchase eleven body worn cameras ("BWC's") for use by Department field personnel; and

WHEREAS, the purpose of the BWC's is to further enhance the customer service that the field staff provides to the residents and businesses of the City, as well as to provide greater accountability for the actions of the Officers and Field Supervisors of the Department when physically interacting with the public; and

WHEREAS, the implementation of the BWC's will greatly assist the Department in capturing additional evidence of various violations of the City Code to better compel compliance of code cases; and

WHEREAS, it is becoming increasingly more common for Code Compliance Departments in the State of Florida to utilize BWC's as part of their daily operations; and

WHEREAS, the City of Doral Police Department currently has an active contract with Axon Enterprise, Inc, a sole source provider, to purchase BWC's and other related equipment via contract no. 151089, City of Tucson, Arizona (National Intergovernmental

Purchasing Alliance) (“Exhibit A”), where said contract was authorized by the Mayor and City Council via Resolution No. 17-215 on December 13, 2017 (“Exhibit B”); and

WHEREAS, the BWC’s will be purchased through the Information Technology budget account 001.22005.500464 for fiscal year 2021/2022 and 2022/2023 in the amount of \$17,576.99 and \$17,577.00, respectively, as detailed in Axon Enterprise, Inc. quote Q-325550-44399.531BR (“Exhibit C”); and

WHEREAS, Staff respectfully requests that the Mayor and City Council authorize the City Manager to purchase eleven BWC’s and related licenses and accessories for the Code Compliance Department.

NOW, THEREFORE, BE IT RESOLVED BY THE MAYOR AND THE CITY COUNCIL OF THE CITY OF DORAL, FLORIDA, AS FOLLOWS:

Section 1. Recitals. The above recitals are confirmed, adopted, and incorporated herein and made a part hereof by this reference.

Section 2. Approval. Pursuant to Section 2-322 of the City’s Code of Ordinances, the purchase of the requested eleven body worn cameras and related licenses and accessories with Axon Enterprise, Inc, a sole source provider, via quote Q-325550-44399.531BR and paid for through the Information Technology budget account 001.220005.500464.

Section 3. Authorization. The City Manager is hereby authorized to purchase the body worn cameras and related equipment and licenses and to expend budgeted funds on behalf of the City with respect to the purchase approved herein.

Section 4. Implementation. The City Manager and the City Attorney are hereby authorized to take such further action as may be necessary to implement the purpose and the provisions of this Resolution.

Section 5. Effective Date. This Resolution shall become effective immediately upon its adoption.

The foregoing Resolution was offered by Councilmember Mariaca who moved its adoption. The motion was seconded by Councilmember Cabral and upon being put to a vote, the vote was as follows:

Mayor Juan Carlos Bermudez	Yes
Vice Mayor Pete Cabrera	Yes
Councilwoman Digna Cabral	Yes
Councilwoman Claudia Mariaca	Yes
Councilman Oscar Puig-Corve	Yes

PASSED AND ADOPTED this 13 day of October 2021.



JUAN CARLOS BERMUDEZ, MAYOR

ATTEST:



CONNIE DIAZ, MMC
CITY CLERK

APPROVED AS TO FORM AND LEGAL SUFFICIENCY
FOR THE USE AND RELIANCE OF THE CITY OF DORAL ONLY:



LUIS FIGUEREDO, ESQ.
CITY ATTORNEY

EXHIBIT “A”



MEMORANDUM

DATE: January 20, 2015

TO: Nathan Daou, CPPB, C.P.M., A.P.P.
Contract Administrator

FROM: Gillian Needham
Senior Contract Officer

Subject: Executive Summary - Request for Proposal No. 151089
Body Worn Cameras

Dept./Div.:	TPD/ Logistics	Date Issued:	September 24, 2014
Pre-Proposal Date:	October 3, 2014	No. of Individuals Attending:	10
Due Date:	October 20, 2014	No. of Proposals Received:	12
Negotiated Value:	See Below	pCard Accepted:	yes

BACKGROUND

The City of Tucson issued the above referenced Request for Proposal to select a contractor to Body Worn Cameras services. The solicitation was publicly posted on the City's website and notices were emailed to all registered vendors who have indicated email is their preferred delivery.

EVALUATION

A committee was formed to evaluate the proposals based upon the selection criteria set forth in the original RFP. The committee was comprised of the following members and signed Committee Member Statements were received from all.

Voting Committee Members

LT. Joe Puglia, Tucson Police Department
Captain Walter Mercer, DPS
Bill Peck, City of Tucson IT Department

Non-Voting Committee Members

George Garman	Dan Moore
Lisa Judge	Jim Webb
Lawrence McDowell	Bart Rohr
Mike Merrill	Michael Silva
Yvonne Morken	Ed Schwenn
Raymon Smith	Tim Reese
Jacques Sproken	Allen Smith
Mark Timpf	Mitch Vipond
Josephine Cervantes	Matt Ronstadt
Gene Myers	Brett Kaczynski
Karen Hochede	Alisa Cunningham
Jesse Niwa	Jobe Dickenson

The City received proposals from the following firms:

Business Solutions	Johnathan Hick Marine
L-3 Communications	Coban Technologies
Taser International	Voice Products Inc.
Heath Bidau	Pre-Ventronics
Linear Systems	Corporate Technologies Solutions
Gatekeeper Systems Inc.	American Video and Security Solutions
Viewu	

Prior to releasing the proposals to the committee, I conducted an initial review of the proposals to ensure that all requested information had been submitted. As a result, all proposals were deemed eligible for the committee's review. The committee is charged with the final determination of acceptability.

On October 23, 2014, I met with the evaluation committee and discussed the role of the committee and the evaluation process. Each committee member received a copy of the City's Guidelines for Evaluation, the Evaluation Committee Responsibilities document, the evaluation criteria and copies of the proposals.

The committee reconvened on October 29, 2014, to discuss the relative strengths and weaknesses of the proposals with regard to the evaluation criteria set forth in the solicitation. After discussing all of the proposals, the committee members individually scored and ranked the proposals. The committee members' rankings were totaled to arrive at an overall ranking. As a result, the committee recommended shortlisting to the top three ranked firms:

Taser International
L-3 Communications
Coban Technologies

On November 7, 2014, the City requested product demonstrations from the three shortlisted vendors. It was requested that each vendor provide five cameras with all mounting solutions available.

On November 12, 2014, L-3 submitted a request to withdraw their proposal from consideration, citing that they were removing their product from the market and returning to the research and development phase. On November 17, 2014 Coban cited similar issues with their product and asked to remove their submission from evaluation also. The Procurement Department granted the request for withdrawal of both proposals.

The evaluation process for Taser International continued with the Tucson Police Department coordinating a variety of simulated field tests to document the differences between the mounting solutions and camera components. On December 15, 2014, the committee reconvened to view the video footage that was collected. After discussing the videos, the committee members individually scored Taser's proposal, and recommended awarding to Taser International.

On December 15, 2014, a request for Best and Final Offer was sent to Taser International. The request asked for revised pricing, additional information and pricing on Intergraph coordination program, and future replacement of products.

NEGOTIATED VALUE

Taser decreased all pricing 5% to 15% across the board on products including cameras, mounting solutions, docking stations and software. Taser also introduced an unlimited data package that will provide the Tucson Police Department with the ability to forecast and plan financially for storage needs. They also included special pricing for the Intergraph coordination project.

CONTRACT OFFICER RECOMMENDATION:

I attest that the evaluation process was conducted in accordance with the Tucson Procurement Code and all applicable rules and regulations. Based upon the evaluation committee's recommendation, it is recommended that this contract shall be awarded to:

Concurrence:

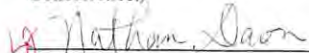
Nathan Daou
Contract Administrator

Taser International

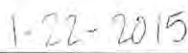
Date



CITY OF
TUCSON
DEPARTMENT OF
PROCUREMENT

AFFIRMATION OF POSTING NOTICE OF REQUEST FOR PROPOSALS

I, Carole Quintana, affirm that on SEPTEMBER 24, 2014, I posted on the City of Tucson Department of Procurement's website (www.tucsonprocurement.com) a public notice of Request for Proposal #151089 for Body Worn Cameras. Proposals submitted in response to Request for Proposal #151089 had to be received by the City of Tucson Department of Procurement by 4:00 PM on OCTOBER 20, 2014.

Carole Quintana



MEMORANDUM

DATE: January 20, 2015

TO: Nathan Daou, CPPB, C.P.M., A.P.P.
Contract Administrator

FROM: 
Gillian Needham
Senior Contract Officer

Subject: Executive Summary - Request for Proposal No. 151089
Body Worn Cameras

Dept./Div.:	TPD/ Logistics	Date Issued:	September 24, 2014
Pre-Proposal Date:	October 3, 2014	No. of Individuals Attending:	10
Due Date:	October 20, 2014	No. of Proposals Received:	12
Negotiated Value:	See Below	pCard Accepted:	yes

BACKGROUND

The City of Tucson issued the above referenced Request for Proposal to select a contractor to Body Worn Cameras services. The solicitation was publicly posted on the City's website and notices were emailed to all registered vendors who have indicated email is their preferred delivery.

EVALUATION

A committee was formed to evaluate the proposals based upon the selection criteria set forth in the original RFP. The committee was comprised of the following members and signed Committee Member Statements were received from all.

Voting Committee Members

LT. Joe Puglia, Tucson Police Department
Captain Walter Mercer, DPS
Bill Peck, City of Tucson IT Department

Non-Voting Committee Members

George Garman
Lisa Judge
Lawrence McDowell
Mike Merrill
Yvonne Morken
Raymon Smith
Jacques Sproken
Mark Timpf
Josephine Cervantes
Gene Myers
Karen Hochede
Jesse Niwa

Dan Moore
Jim Webb
Bart Rohr
Michael Silva
Ed Schwenn
Tim Reese
Allen Smith
Mitch Vipond
Matt Ronstadt
Brett Kaczynski
Alisa Cunningham
Jobe Dickenson

The City received proposals from the following firms:

Business Solutions
L-3 Communications
Taser International
Heath Bidau
Linear Systems
Gatekeeper Systems Inc.
Viewu

Johnathan Hick Marine
Coban Technologies
Voice Products Inc.
Pre-Ventronics
Corporate Technologies Solutions
American Video and Security Solutions

Prior to releasing the proposals to the committee, I conducted an initial review of the proposals to ensure that all requested information had been submitted. As a result, all proposals were deemed eligible for the committee's review. The committee is charged with the final determination of acceptability.

On October 23, 2014, I met with the evaluation committee and discussed the role of the committee and the evaluation process. Each committee member received a copy of the City's Guidelines for Evaluation, the Evaluation Committee Responsibilities document, the evaluation criteria and copies of the proposals.

The committee reconvened on October 29, 2014, to discuss the relative strengths and weaknesses of the proposals with regard to the evaluation criteria set forth in the solicitation. After discussing all of the proposals, the committee members individually scored and ranked the proposals. The committee members' rankings were totaled to arrive at an overall ranking. As a result, the committee recommended shortlisting to the top three ranked firms:

Taser International
L-3 Communications
Coban Technologies

On November 7, 2014, the City requested product demonstrations from the three shortlisted vendors. It was requested that each vendor provide five cameras with all mounting solutions available.

On November 12, 2014, L-3 submitted a request to withdraw their proposal from consideration, citing that they were removing their product from the market and returning to the research and development phase. On November 17, 2014 Coban cited similar issues with their product and asked to remove their submission from evaluation also. The Procurement Department granted the request for withdrawal of both proposals.

The evaluation process for Taser International continued with the Tucson Police Department coordinating a variety of simulated field tests to document the differences between the mounting solutions and camera components. On December 15, 2014, the committee reconvened to view the video footage that was collected. After discussing the videos, the committee members individually scored Taser's proposal, and recommended awarding to Taser International.

On December 15, 2014, a request for Best and Final Offer was sent to Taser International. The request asked for revised pricing, additional information and pricing on Intergraph coordination program, and future replacement of products.

NEGOTIATED VALUE

Taser decreased all pricing 5% to 15% across the board on products including cameras, mounting solutions, docking stations and software. Taser also introduced an unlimited data package that will provide the Tucson Police Department with the ability to forecast and plan financially for storage needs. They also included special pricing for the Intergraph coordination project.

CONTRACT OFFICER RECOMMENDATION:

I attest that the evaluation process was conducted in accordance with the Tucson Procurement Code and all applicable rules and regulations. Based upon the evaluation committee's recommendation, it is recommended that this contract shall be awarded to:

Taser International

Concurrence:

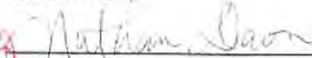

Nathan Daou
Contract Administrator

1-22-2015

Date

CITY OF TUCSON

Contract 151089

for

Body Worn Cameras and Storage System

with

Taser International, Inc.

Effective: February 2, 2015

The following documents comprise the executed contract between the City of Tucson and Taser International, Inc., effective February 2, 2015:

- I. City of Tucson
(Includes Term, Amendments, Pricing and National Cooperative Language)
- II. Notice to Award
- III. Supplier's Response to the RFP
(Includes Scope of Work)



Axon Dock Hardware

Model	Product Description	Agency Price
74009	1-bay + Core Axon Dock 2 for Axon Body 2	\$249.00 ea.
74008	6-bay + Core Axon Dock 2 for Axon Body 2	\$1,495.00 ea.
74011	1-bay for Axon Body 2	\$249.00 ea.
74010	6-bay for Axon Body 2	\$1,346.00 ea.
70026	6-bay + Core Axon Dock for Axon Flex and Axon Body	\$1,495.00 ea.
70023	1-bay + Core Axon Dock for Axon Flex and Axon Body	\$249.00 ea.
70028	Individual bay Axon Dock for Axon Flex and Axon Body	\$249.00 ea.
70027	Axon Dock Core, compatible with all 1-bays and 6-bays	\$149.00 ea.
70033	Wall mount, Axon Dock for Axon Flex and Axon Body	\$35.00 ea.
70040	Desk plate, Axon Dock, 6-bay for Axon Flex and Axon Body	\$35.00 ea.

Customer Care Extended Warranty

Model	Product Description	Agency Price
87029	Axon Body 2 cam 2-year extended warranty	\$199.95 ea.
87030	Axon Dock 2 for Axon Body 2, 2-year extended warranty, single bay + core	\$129.90 ea.
87031	Axon Dock 2 for Axon Body 2, 2-year extended warranty 6-bay + hub	\$499.90 ea.
70037	Axon Dock for Axon Body and Axon Flex, 2-year extended warranty, 6-bay	\$499.90 ea.
70038	Axon Dock for Axon Body and Axon Flex, 2-year extended warranty, single bay	\$129.90 ea.
73033	Axon Flex kit 2-year extended warranty	\$299.95 ea.
73074	Axon Body cam 2-year extended warranty	\$199.95 ea.

Axon Fleet License & Storage Plans (one license per vehicle)*

Model	Product Description	Agency Price
87010	Fleet Basic: 1 year (100 GB of included storage and Evidence.com basic license features)	\$300.00 ea
85161	Fleet Unlimited HD: 3 year (unlimited HD storage for Fleet cameras, Pro Evidence.com license features, extended Axon camera warranty)	\$1,404.00 ea
85162	Fleet Unlimited HD: 5 year (unlimited HD storage for Fleet cameras, Pro Evidence.com license features, extended Axon camera warranty)	\$2,340.00 ea.
85163	Fleet Unlimited HD, annual payment (unlimited HD storage for Fleet cameras, Pro Evidence.com license features, extended Axon camera warranty). Must purchase under a 3- or 5- year term	\$468.00 ea.

Evidence.com Services

Model	Product Description	Agency Price
87001	Basic Evidence.com license: 1 year	\$180.00 ea.
88001	Standard Evidence.com license: 1 year	\$300.00 ea.
89001	Pro Evidence.com license: 1 year	\$468.00 ea.
85100	Evidence.com integration license, annual payment	\$180.00 ea.
85078	Ultimate Evidence.com annual payment*	\$660.00 ea.
85123	Evidence.com Unlimited Plan annual payment*	\$948.00 ea.
85130	Officer Safety Plan annual payment**	\$1,188.00 ea.
85035	Evidence.com storage (GB): 1 year	\$0.75 ea.
85054	TASER Assurance Plan Axon Flex annual payment	\$276.00 ea.
85079	TASER Assurance Plan Axon Dock annual payment (based on the number of cameras purchased)	\$36.00 ea.
87026	TASER Assurance Plan Axon Dock 2 annual payment (based on the number of Docks purchased)	\$216.00 ea.
85055	Axon Full Service	\$15,000 ea.
85144	Axon Starter	\$2,500 ea.
85146	Axon 1-Day Service	\$2,000 ea.
N.A.	Basic remote support	Free
73094	Viewer (fees vary based on configuration needs, viewer desired, and market price)	Variable

*This license tier is only available for 3-year or 5-year terms

**This license tier is only available for 5-year terms.



Axon Flex Accessories

Model	Product Description	Agency Price
73004	USB Sync Cable w/ Wall Charger	\$14.95 ea.
73008	Oakley Clip	\$19.95 ea.
73088	Ratchet Collar/Versatile/Cap Mount	\$29.95 ea.
73062	Ball Cap Mount	\$29.95 ea.
73010	Low Rider Headband	\$49.95 ea.
73058	Low Rider Headband, Large	\$54.95 ea.
73036	Controller Holster, Flex, Belt Clips	\$29.95 ea.
73011	Epaulette Mount	\$19.95 ea.
73013	Helmet Mount	\$19.95 ea.
73020	Universal Magnet Clip	\$7.95 ea.
73021	Multi-Mounting Kit, Flex (Low Rider headband, Ratchet Collar mount, Epaulette mount, Oakley kit)	\$199.95 ea.
73059	Ballistic Vest Mount, Rotating	\$19.95 ea.
73005	Cable, Straight to Right Angle, 36"	\$5.95 ea.
73067	Cable, Coiled, Straight to Right Angle, 36"	\$12.95 ea.
73060	Cable, Coiled, Straight to Right Angle 48"	\$12.95 ea.
73081	TASER CAM HD/Axon Camera Universal Charger w/ U.S. and International Adaptors	\$14.95 ea.
73099	Helmet Mount, SWAT Kit, Axon Flex	\$29.95 ea.

Freight Policy Freight is the responsibility of the purchaser. All orders are shipped F.O.B. Scottsdale, AZ via Fed-Ex ground and billed as a separate line item on invoice. All taxes, duties and customs, where applicable, are the responsibilities of the customer.

Pricing Pricing for Law Enforcement/Correctional Agencies Only. Must be a sworn law enforcement officer to purchase. This is not-to-exceed pricing. Additional discounts may be available. Contact TASER for a quote specific to your agency's needs.

Order Lead Time 4 to 6 weeks ARO. ALL SALES ARE FINAL.

For delivery status or information on how to place an order, call our sales department at 800-978-2737, fax: 480-991-0791

TASER International, Inc.'s Sales Terms and Conditions for Direct Sales to End User Purchasers apply to all sales and are available at <http://www.taser.com/sales-terms-and-conditions>.

Flak Jacket is a trademark of Oakley, Inc., Motorola is a trademark of Motorola Trademark Holdings, LLC., and VELCRO is a trademark of Velcro Industries B.V.

AXON, Axon, Axon Body 2, Axon Flex, Axon Fleet, Axon Signal, Evidence.com, TASER, TASER CAM, and © are trademarks of TASER International, Inc., some of which registered in the US and other countries. For more information, visit www.TASER.com/legal. All rights reserved. © 2016 TASER International, Inc.

CONTRACT AMENDMENT

CITY OF TUCSON DEPARTMENT OF PROCUREMENT
255 W. ALAMEDA, 6TH FLOOR, TUCSON, AZ 85701
P.O. BOX 27210, TUCSON, AZ 85726
(520) 837-4137
ISSUE DATE: MARCH 30, 2016

CONTRACT NO.: 151089
CONTRACT AMENDMENT NO.: ONE (1)
PAGE 1 of 3
JM/sa
CONTRACT OFFICER: JENN MYERS

THIS CONTRACT IS AMENDED AS FOLLOWS:

BODY WORN CAMERAS

ITEM ONE (1): RENEWAL

Pursuant to Contract No. 151089, Special Terms and Conditions, Term and Renewal, the City is hereby exercising its option to renew the contract for the period of February 1, 2016 through January 31, 2017.

ITEM TWO (2): INDEMNIFICATION

Paragraph 19 of the Standard Terms and Conditions section is hereby replaced in its entirety with the following paragraph:

19. INDEMNIFICATION: To the fullest extent permitted by law, Contractor, its successors, assigns and guarantors, shall pay, defend, indemnify and hold harmless City of Tucson, its agents, representatives, officers, directors, officials and employees from and against all allegations, demands, proceedings, suits, actions, claims, including claims of patent or copyright infringement, damages, losses, expenses, including but not limited to, attorney fees, court costs, and the cost of appellate proceedings, and all claim adjusting and handling expense, related to, arising from or out of or resulting from any negligent actions, negligent acts, errors, mistakes or omissions caused in whole or part by Contractor relating to work, services and/or products provided in the performance of this Contract, including but not limited to, any Subcontractor or anyone directly or indirectly employed by any of them or anyone for whose acts any of them may be liable and any injury or damages claimed by any of Contractor's and Subcontractor's employees. It is agreed that Contractor will be responsible for primary loss investigation, defense and judgment costs where this indemnification is applicable. The Contractor agrees to waive all rights of subrogation against the City of Tucson, its agents, representatives, officers, directors, officials, employees and volunteers for losses arising from the work performed by the Contractor for the City of Tucson.

Contractor is responsible for compliance with the Patient Protection and Affordable Care Act (ACA), for its employees in accordance with 26 CFR §54. 4980H. Additionally, Contractor is responsible for all applicable IRS reporting requirements related to ACA. If Contractor or any of Contractor's employees is certified to the City as having received a premium tax credit or cost sharing reduction which contributes to or triggers an assessed penalty against the City, or Contractor fails to meet reporting requirements pursuant to section 6056 resulting in a penalty to City, Contractor indemnifies City from and shall pay any assessed tax penalty.

CONTRACT AMENDMENT

CITY OF TUCSON DEPARTMENT OF PROCUREMENT
255 W. ALAMEDA, 6TH FLOOR, TUCSON, AZ 85701
P.O. BOX 27210, TUCSON, AZ 85726
(520) 837-4137
ISSUE DATE: MARCH 30, 2016

CONTRACT NO.: 151089
CONTRACT AMENDMENT NO.: ONE (1)
PAGE 2 of 3
JM/sa
CONTRACT OFFICER: JENN MYERS

(This page intentionally left blank.)

ALL OTHER PROVISIONS OF THE CONTRACT SHALL REMAIN IN THEIR ENTIRETY.

CONTRACTOR: _____

CONTRACTOR HEREBY ACKNOWLEDGES RECEIPT OF AND UNDERSTANDING OF THE ABOVE AMENDMENT.

DocuSigned by:
 3/30/2016

Signature of person authorized to sign Date

Josh Isner, EVP Global Sales

Name and Title (typed or printed legibly)

TASER International, Inc.

Company Name

17800 N. 85th Street

Address

contracts@taser.com

Email Address

Scottsdale AZ 85255

City State Zip

Contact information for Sales/Account Representative for daily business operations:

Sales Ops

Name and Title (typed or printed legibly)

480-991-0797

Phone Number

CITY OF TUCSON: _____

THE ABOVE REFERENCED CONTRACT AMENDMENT IS HEREBY EXECUTED THIS 30th DAY OF March, 2016, AT TUCSON, ARIZONA.

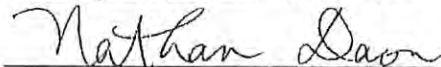
for 
Marcheta Gillesple, CPPO, C.P.M., CPPB, CPM as Director of Procurement and not personally

CONTRACT AMENDMENT

CITY OF TUCSON DEPARTMENT OF PROCUREMENT
255 W. ALAMEDA, 6TH FLOOR, TUCSON, AZ 85701
P.O. BOX 27210, TUCSON, AZ 85726
PHONE: (520) 837-4137 / FAX: (520) 791-4735
Jenn.Myers@tucsonaz.gov
ISSUE DATE: Tuesday, June 20, 2017

CONTRACT: 161089
CONTRACT AMENDMENT NUMBER: SIX (6)
PAGE 1 of 1
JM/car
SENIOR CONTRACT OFFICER: JENN MYERS

Body Worn Cameras

ITEM ONE (1): NATIONAL FIELD TRIAL AGREEMENT

The attached National Field Trial Agreement shall hereby be added to the contract. This agreement shall be utilized by Axon to offer agencies the ability evaluate products on a free-of-charge/loan basis.

*******END OF AMENDMENT*******

ALL OTHER PROVISIONS OF THE CONTRACT SHALL REMAIN IN THEIR ENTIRETY.

CONTRACTOR: AXON

CONTRACTOR HEREBY ACKNOWLEDGES RECEIPT OF AND UNDERSTANDING OF THE ABOVE AMENDMENT.

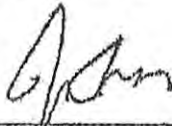

6/23/17

Signature of person authorized to sign Date

Josh Isner, EVP Global Sales
Name and Title (typed or printed legibly)

Axon Enterprise, Inc
Company Name

17800 N. 85th St, Scottsdale, AZ 85252
Address

Contracts@axon.com
Email Address

Scottsdale AZ 85255
City State Zip

Contact information for Sales/Account Representative for daily business operations:

Chad Kepler

Name and Title (typed or printed legibly)

480-991-0797

Phone Number

Contracts@axon.com
Email Address

CITY OF TUCSON:

THE ABOVE REFERENCED CONTRACT AMENDMENT

IS HEREBY EXECUTED THIS 26th DAY

OF June, 2017, AT TUCSON, ARIZONA.

Nathan Daon
for Marcheta Gillespie, CPPO, C.P.M., CPPB, CPM
as Director of Procurement and not personally



National Field Trial Agreement

This Agreement grants the right to use the Axon Enterprise, Inc. ("Axon") Product(s) identified in this Agreement to your law enforcement agency ("Agency" or "you") on loan and free of charge for a trial and evaluation of the Product(s) by the Agency.¹ The Trial Period is 365 days unless extended by Axon. This offer from Axon is void where prohibited by law or regulation.

1. Trial Kit. The Trial Kit may include the following:

- 74016 – Axon Body 2
- 70042 – Axon Dock, Single Camera Bay
- 70043 – Axon Dock, 6-Camera Bay

which will be specified on your Sales Order ("Product"). Axon reserves the right to limit the number of Trial Kits you receive. Axon reserves the right to supply a refurbished Product as part of the Trial Kit. Axon's warranty, limitations and releases for the Products is applicable and available on Axon's website at www.axon.com.

2. Agency Obligations. You agree to only use the Product for trial and evaluation purposes and will not: (a) reproduce or modify the Product; (b) rent, sell, lease or otherwise transfer the Product; (c) use the Product or Evidence.com to store or transmit infringing, libelous, or otherwise unlawful or tortuous material or to store or transmit material in violation of third-party privacy rights; or (d) attempt to gain unauthorized access to Evidence.com or related systems or networks. You agree to comply with all Axon materials, including all addendums attached hereto regarding the Products during the Trial Period. Upon request of Axon, you also agree to cooperate and participate in a case study involving the Product and your use of the Product. You agree that Axon will have a non-exclusive, perpetual license to utilize the results and any report or publication resulting from the case study in Axon's training, markets and sales materials.

3. Return of Product. You agree to either return the Product to Axon within 10 days after the end of the Trial Period, or be invoiced for the full MSRP of the Product and pay the invoice along with any applicable taxes and shipping costs pursuant to Axon's standard sales terms and conditions. If any individual piece of the Trial Kits not returned to Axon at the end of the Trial Period, then Axon will issue to you an invoice for the MSRP of the unreturned item(s). You agree to pay the invoice along with any applicable taxes. In the event you decide to enter into a contract with Axon after the Trial Period for the continued use of the Evidence.com Services, Axon will negotiate

pricing with you at that time.

If you choose to return the Product to Axon instead of purchasing the Product, you agree to return the Product to Axon in good working condition, normal wear and tear excepted. Axon reserves the right to charge you if there is damage beyond the normal wear and tear and outside of the warranty coverage.

Before you return the Product, it is your responsibility to download the Product and keep a backup copy of the data. All data stored in the Product will be erased upon receipt of the Product by Axon. Product is to be returned via the RMA process to Axon Enterprise, Inc., 17800 N. 85th Street, Scottsdale, Arizona USA 85255, Attention: Trial Returns.

4. Agency Data. With your return of the Product, you may request Axon make available to you for download your data and any attachments that you uploaded to Evidence.com during the Trial Period. During the 30 days following this request you may retrieve your data from the Evidence.com services. After this 30-day period, Axon will have no obligation to maintain or provide any data uploaded to Evidence.com and will thereafter, unless legally prohibited, delete all of this data in Axon's systems or otherwise in its possession or control.

5. Proprietary Information. You agree that Axon has and claims various proprietary rights in the hardware, firmware, software, and the integration of ancillary materials, knowledge, and designs that constitute the Product, and that you will not directly or indirectly cause any proprietary rights to be violated.

6. Intellectual Property. You acknowledge and agree that you do not acquire ownership of any rights in the Product or Evidence.com services, and that Axon and its affiliates own all right, title and interest in and to the Product and Evidence.com services, and its data and any modifications, alterations, translations or derivative works relating to the Products and Evidence.com services.

7. Confidentiality. You agree that your evaluation of the Product is confidential. You agree that you shall not directly or indirectly disclose any information about the Product and your evaluation of the Product to any third person or entity and only to those people of your Agency who have a need to know.

Formal Matters.

A. **Signature.** Your signature warrants and acknowledges that you are authorized to execute this Agreement on behalf of your Agency.

B. **Entire Agreement; Modification; Severability.** This Agreement incorporates the Community One Field Trial



National Field Trial Agreement

Addendum in its entirety and contains all the terms and conditions agreed on by the parties regarding the Trial Kit. Any previous agreements between the parties regarding a free trial of the Product are replaced by this Agreement. This Agreement can be modified or changed only by a written Instrument signed by both parties. This Agreement is contractual and not a mere recital. If any part of this Agreement is held indefinite, invalid, or otherwise unenforceable, the rest of the Agreement will continue in full force and effect. You must accept this Agreement unmodified and as written.

C. Relationship of the Parties. The parties are independent contractors and this Agreement does not create a partnership, franchise, joint venture, agency, fiduciary or employment relationship between the parties.

D. Assignment. You must not, by operation of law or otherwise, assign any of your rights or delegate any of your obligations under this Agreement without the prior express written consent of Axon.

Axon Enterprise, Inc.

Signature: _____

Name: _____

Title: _____

Agency

Signature: _____

Name: _____

Title: _____

[†]This Agreement does not cover trials or evaluations solely of any Axon beta software or firmware.

▲ ▲ AXON, Axon, Axon Body 2, Axon Capture, Axon Dock Axon View, Evidence.com, and Evidence Sync are trademarks of Axon Enterprise, Inc., some of which are registered in the US and other countries. For more information, visit www.axon.com/legal. All rights reserved. © 2017 Axon Enterprise, Inc.

NATIONAL FIELD TRIAL ADDENDUM

This Addendum sets forth the terms and conditions for the delivery, use, and support of Axon products and services as detailed in the Field Trial Agreement, which is hereby incorporated by reference.

1 **Definitions.**

"Documentation" means the (i) specifications, explanatory or informational materials, whether in paper or electronic form, that relate to the Services provided under this Addendum, or (ii) user manuals, technical manuals, training manuals, warnings, specification or other explanatory or informational materials, whether in paper or electronic form, that relate to the Products provided under this Addendum.

"Evidence.com Service" means Axon web services for Evidence.com, the Evidence.com site, Evidence Sync software, Axon Capture App, Axon View App, other software, maintenance, storage, and product or service provided by us under this Addendum for use with Evidence.com. This does not include any Third Party Applications, hardware warranties, or the my.evidence.com services.

"Installation Site" means the location(s) where the Products are to be installed.

"Products" means all Axon equipment, software, cloud based services, Documentation and software maintenance releases and updates provided by Axon under this Addendum.

"Quote" is an offer to sell, is valid only for products and services listed on the quote at prices on the quote. All Quotes referenced in this Addendum or issued and accepted after the Effective Date of this Addendum will be subject to the terms of this Addendum. Any terms and conditions contained within the Agency's purchase order in response to the Quote will be null and void and shall have no force or effect. Axon is not responsible for pricing, typographical, or other errors in any offer by Axon and Axon reserves the right to cancel any orders resulting from such errors. Axon reserves the right to adjust prices or Products unless otherwise specified in the Quote.

"Services" means all services provided by Axon pursuant to this Addendum.

"Agency Content" means software, data, text, audio, video, images or other Agency content or any of the Agency's end users (a) run on the Evidence.com Services, (b) cause to interface with the Evidence.com Services, or (c) upload to the Evidence.com Services under the Agency account or otherwise transfer, process, use or store in connection with the Agency account.

- 2 **Agency Responsibilities.** The Agency is responsible for (i) use of Axon Products (including any activities under the Agency Evidence.com account and use by Agency employees and agents), (ii) breach of this Addendum or violation of applicable law by the Agency or any of the Agency's end users, (iii) Agency Content or the combination of Agency Content with other applications, content or processes, including any claim involving alleged infringement or misappropriation of third party rights by Agency Content or by the use of Agency Content, (iv) a dispute between the Agency and any third party over Agency use of Axon products or the collection or use of Agency Content, (v) any hardware or networks that the Agency connects to the Evidence.com Services, and (vi) any security settings the Agency establishes to interact with or on the Evidence.com Services.

3 Warranties.

3.1 Hardware Limited Warranty. Axon warrants that its law enforcement hardware products are free from defects in workmanship and materials for a period of ONE (1) YEAR from the date of receipt. Extended warranties run from the date of purchase of the extended warranty through the balance of the 1-year limited warranty term plus the term of the extended warranty measured after the expiration of the 1-year limited warranty. Axon-Manufactured Accessories are covered under a limited 90-DAY warranty from the date of receipt. Non-Axon manufactured accessories are covered under the manufacturer's warranty. If Axon determines that a valid warranty claim is received within the warranty period, Axon agrees to repair or replace the Product. Axon's sole responsibility under this warranty is to either repair or replace with the same or like Product, at Axon's option.

3.2 Warranty Limitations.

3.2.1 The warranties do not apply and Axon will not be responsible for any loss, data loss, damage, or other liabilities arising from: (a) damage from failure to follow instructions relating to the Product's use; (b) damage caused by use with non-Axon products or from the use of cartridges, batteries or other parts, components or accessories that are not manufactured or recommended by Axon; (c) damage caused by abuse, misuse, intentional or deliberate damage to the product, or force majeure; (d) damage to a Product or part that has been repaired or modified by persons other than Axon authorized personnel or without the written permission of Axon; or (e) if any Axon serial number has been removed or defaced.

3.2.2 To the extent permitted by law, the warranties and the remedies set forth above are exclusive and Axon disclaims all other warranties, remedies, and conditions, whether oral or written, statutory, or implied, as permitted by applicable law. If statutory or implied warranties cannot be lawfully disclaimed, then all such warranties are limited to the duration of the express warranty described above and limited by the other provisions contained in this Agreement.

3.2.3 Axon's cumulative liability to any Party for any loss or damage resulting from any claims, demands, or actions arising out of or relating to any Axon product will not exceed the purchase price paid to Axon for the product or if for services, the amount paid for such services over the prior 12 months preceding the claim. In no event will either Party be liable for any direct, special, indirect, incidental, exemplary, punitive or consequential damages, however caused, whether for breach of warranty, breach of contract, negligence, strict liability, tort or under any other legal theory.

3.3 Warranty Returns. If a valid warranty claim is received by Axon within the warranty period, Axon agrees to repair or replace the Product which Axon determines in its sole discretion to be defective under normal use, as defined in the Product Instructions. Axon's sole responsibility under this warranty is to either repair or replace with the same or like Product, at Axon's option.

3.3.1 For warranty return and repair procedures, including troubleshooting guides, please go to Axon's websites www.axon.com/support or www.evidence.com, as indicated in the appropriate product user manual or quick start guide.

3.3.2 Before delivering product for warranty service, it is the Agency's responsibility to upload the data contained in the product to the EVIDENCE.com services or download the product data and keep a separate backup copy of the contents. Axon is not responsible for any loss of software programs, data, or other information contained on the storage media or any other part of the product services.

4 A replacement product will be new or like new and have the remaining warranty period of the original product or 90 days from the date of replacement or repair, whichever period is longer. When a product or part is exchanged, any replacement item becomes Purchaser's property and the replaced item becomes Axon's

property.

Evidence.com Terms of Use Addendum

- 1 **Access Rights.** Upon the purchase or granting of a subscription from Axon and the opening of an Evidence.com account the Agency will have access and use of the Evidence.com Services for the storage and management of Agency Content during the subscription term (**Term**). The Evidence.com Service and data storage are subject to usage limits. The Evidence.com Service may not be accessed by more than the number of end users specified in the Quote. If Agency becomes aware of any violation of this Addendum by an end user, the Agency will immediately terminate that end user's access to Agency Content and the Evidence.com Services.
- 2 **Agency Owns Agency Content.** The Agency controls and owns all right, title, and interest in and to Agency Content and Axon obtains no rights to the Agency Content and the Agency Content are not business records of Axon. The Agency is solely responsible for the uploading, sharing, withdrawal, management and deletion of Agency Content. Axon will have limited access to Agency Content solely for the purpose of providing and supporting the Evidence.com Services to the Agency and Agency end users. The Agency represents that the Agency owns Agency Content; and that none of Agency Content or Agency end users' use of Agency Content or the Evidence.com Services will violate this Addendum or applicable laws.
- 3 **Evidence.com Data Security.**
 - 3.1. **Generally.** Axon will implement commercially reasonable and appropriate measures designed to secure Agency Content against accidental or unlawful loss, access or disclosure. Axon will maintain a comprehensive Information Security Program (**ISP**) that includes logical and physical access management, vulnerability management, configuration management, incident monitoring and response, encryption of digital evidence uploaded, security education, risk management, and data protection. The Agency is responsible for maintaining the security of end user names and passwords and taking steps to maintain appropriate security and access by end users to Agency Content. Log-in credentials are for Agency internal use only and Agency may not sell, transfer, or sublicense them to any other entity or person. The Agency agrees to be responsible for all activities undertaken by the Agency, Agency employees, Agency contractors or agents, and Agency end users which result in unauthorized access to the Agency account or Agency Content. Audit log tracking for the video data is an automatic feature of the Services which provides details as to who accesses the video data and may be downloaded by the Agency at any time. The Agency shall contact Axon immediately if an unauthorized third party may be using the Agency account or Agency Content or if account information is lost or stolen.
 - 3.2. **FBI CJIS Security Addendum.** For customers based in the United States, Axon agrees to the terms and requirements set forth in the Federal Bureau of Investigation (**FBI**) Criminal Justice Information Services (**CJIS**) Security Addendum for the Term of this Addendum.
- 4 **Our Support.** Axon will make available updates as released by Axon to the Evidence.com Services. Updates may be provided electronically via the Internet. Axon will use reasonable efforts to continue supporting the previous version of any API or software for 6 months after the change (except if doing so (a) would pose a security or intellectual property issue, (b) is economically or technically burdensome, or

- (c) is needed to comply with the law or requests of governmental entities. The Agency is responsible for maintaining the computer equipment and Internet connections necessary for use of the Evidence.com Services.
- 5 **Data Privacy.** Axon will not disclose Agency Content or any information about the Agency except as compelled by a court or administrative body or required by any law or regulation. Axon will give notice if any disclosure request is received for Agency Content so the Agency may file an objection with the court or administrative body. The Agency agrees to allow Axon access to certain information from the Agency in order to: (a) perform troubleshooting services for the account upon request or as part of our regular diagnostic screenings; (b) enforce this agreement or policies governing use of Evidence.com Services; or (c) perform analytic and diagnostic evaluations of the systems.
- 6 **Data Storage.** Axon will determine the locations of the data centers in which Agency Content will be stored and accessible by Agency end users. For United States customers, Axon will ensure that all Agency Content stored in the Evidence.com Services remains within the United States including any backup data, replication sites, and disaster recovery sites. Axon may transfer Agency Content to third parties for the purpose of storage of Agency Content. Third party subcontractors responsible for storage of Agency Content are contracted by Axon for data storage services. Ownership of Agency Content remains with the Agency. For use of an Unlimited Evidence.com License unlimited data may be stored in the Agency's Evidence.com account if the data originates from a Axon device.
- 7 **Suspension of Evidence.com Services.** Axon may suspend Agency access or any end user's right to access or use any portion or all of the Evidence.com Services immediately upon notice in accordance with the following:
- 7.1. The Agency or an end user's use of or registration for the Evidence.com Services (i) poses a security risk to the Evidence.com Services or any third party, (ii) may adversely impact the Evidence.com Services or the systems or content of any other customer, (iii) may subject Axon, Axon's affiliates, or any third party to liability, or (iv) may be fraudulent;
- 7.2. Axon will not delete any of Agency Content on Evidence.com as a result of a suspension, except as specified elsewhere in this Addendum.
- 8 **Software Services Warranty.** Axon warrants that the Evidence.com Services will not infringe or misappropriate any patent, copyright, trademark, or trade secret rights of any third party. Axon disclaims any warranties or responsibility for data corruption or errors before the data is uploaded to the Evidence.com Services.
- 9 **License Restrictions.** Neither the Agency nor any Agency end users may, or attempt to: (a) permit any third party to access the Evidence.com Services except as permitted in this Addendum; (b) modify, alter, tamper with, repair, or otherwise create derivative works of any of the Evidence.com Services; (c) reverse engineer, disassemble, or decompile the Evidence.com Services or apply any other process or procedure to derive the source code of any software included in the Evidence.com Services, or allow any others to do the same; (d) access or use the Evidence.com Services in a way intended to gain unauthorized access, avoid incurring fees or exceeding usage limits or quotas; (e) copy the Evidence.com Services in whole or part, except as expressly permitted in this Addendum; (f) use trade secret information contained in the Evidence.com Services, except as expressly permitted in this Addendum; (g) resell, rent, loan, or sublicense the Evidence.com Services; (h) access the Evidence.com Services in order to build a competitive product or service or copy any features, functions, or graphics of the Evidence.com Services;



National Field Trial Agreement

(i) remove, alter, or obscure any confidentiality or proprietary rights notices (including copyright and trademark notices) of ours or our licensors on or within the Evidence.com Services or any copies of the Evidence.com Services; or (j) use the Evidence.com Services to store or transmit infringing, libelous, or otherwise unlawful or tortious material, to store or transmit material in violation of third party privacy rights, or to store or transmit malicious code. All licenses granted in this Addendum are conditional on continued compliance this Addendum, and will immediately and automatically terminate if the Agency does not comply with any term or condition of this Addendum. The Agency may only use our trademarks in accordance with the Axon Trademark Use Guidelines (located at www.axon.com).

Professional Services Addendum

1 **Scope of Services.** The project scope will consist of the Services identified on the Quote.

1.1. The Package for the Axon and Evidence.com related Services are detailed below:

<p>System set up and configuration Setup Axon View on smart phones (if applicable). Configure categories & custom roles based on Agency need. Troubleshoot IT Issues with Evidence.com and Evidence.com Dock (Dock) access. Work with IT to install Evidence Sync software on locked-down computers (if applicable). For the Full Service Package: One on-site session Included</p>
<p>Dock installation Work with Agency to decide ideal location of Dock setup and set configurations on Dock if necessary. Authenticate Dock with Evidence.com using "admin" credentials from Agency. Work with Agency's IT to configure its network to allow for maximum bandwidth and proper operation within Agency's network environment. On site Assistance Included</p>
<p>Dedicated Project Manager Assignment of a specific Axon representative for all aspects of planning the Product rollout (Project Manager). Ideally, the Project Manager will be assigned to the Agency 4-6 weeks prior to rollout.</p>
<p>Weekly project planning meetings Project Manager will develop a Microsoft Project plan for the rollout of Axon camera units, Docks and Evidence.com account training based on size, timing of rollout and Agency's desired level of training. Up to 4 weekly meetings leading up to the Evidence.com Dock installation of not more than 30 minutes in length.</p>
<p>Best practice implementation planning session—1 on-site session to: Provide considerations for establishment of video policy and system operations best practices based on Axon's observations with other agencies. Discuss importance of entering metadata in the field for organization purposes and other best practice for digital data management. Provide referrals of other agencies using the Axon camera products and Evidence.com services Create project plan for larger deployments. Recommend rollout plan based on review of shift schedules.</p>
<p>System Admin and troubleshooting training sessions (only included in Full Service Package) 2 on-site sessions—each providing a step-by-step explanation and assistance for Agency's configuration of security, roles & permissions, categories & retention, and other specific settings for Evidence.com.</p>
<p>Axon instructor training Prior to general user training on Axon camera systems and Evidence.com services, Axon's on-site professional services team will provide training for instructors who can support the Agency's subsequent Axon camera and Evidence.com training needs.</p>
<p>End user go live training and support sessions Provide individual device set up and configuration assistance; pairing with viewers when applicable; and training on device use, Evidence.com and Evidence Sync.</p>
<p>Implementation document packet Evidence.com administrator guides, camera implementation guides, network setup guide, sample policies, and categories & roles guide</p>
<p>Post go live review session</p>

1.2. Additional training days may be added on to any service package for additional fees set forth in the Quote.

- 2 **Out of Scope Services.** Axon is responsible to perform only the Services described on the Quote. Any additional services discussed or implied that are not defined explicitly by the Quote will be considered out of the scope.
- 3 **Delivery of Services.**
- 3.1. **Hours and Travel.** Axon personnel will work within normal business hours, Monday through Friday, 8:30 a.m. to 5:30 p.m., except holidays unless otherwise agreed in advance. All tasks on-site will be performed over a consecutive timeframe unless otherwise agreed to by the Parties in advance. Travel time by Axon personnel to Agency premises will not be charged as work hours performed.
- 3.2. **Changes to Services.** Changes to the scope of Services must be documented and agreed upon by the Parties in a change order. Changes may require an equitable adjustment in the charges or schedule.
- 4 **Authorization to Access Computer Systems to Perform Services.** The Agency authorizes Axon to access relevant Agency computers and network systems solely for the purpose of performing the Services. Axon will work diligently to identify as soon as reasonably practicable the resources and information Axon expects to use, and will provide an initial itemized list to the Agency. The Agency is responsible for, and assumes the risk of any problems, delays, losses, claims, or expenses resulting from the content, accuracy, completeness, and consistency of all data, materials, and information supplied by the Agency.
- 5 **Site Preparation and Installation.** Prior to delivering any Services, Axon will provide 1 copy of the then-current user documentation for the Services and related Products in paper or electronic form (**Product User Documentation**). The Product User Documentation will include all environmental specifications that must be met in order for the Services and related Products to operate in accordance with the Product User Documentation. Prior to the installation of Product (whether performed by the Agency or Axon), the Agency must prepare the Installation Site in accordance with the environmental specifications set forth in the Product User Documentation. Following the installation of the Products, the Agency must maintain the Installation Site where the Products have been installed in accordance with the environmental specifications set forth in the Product User Documentation. In the event that there are any updates or modifications to the Product User Documentation for any Products provided by Axon under this Addendum, including the environmental specifications for the Products, Axon will provide the updates or modifications to Agency when they are generally released by Axon to Axon customers.
- 6 **Liability for Loss or Corruption of Data.** The Agency is responsible for: (i) instituting proper and timely backup procedures for Agency software and data; (ii) creating timely backup copies of Agency software or data that may be damaged, lost, or corrupted due to our provision of Services; and (iii) using backup copies to restore any Agency software or data in the event of any loss of, damage to, or corruption of the operational version of Agency software or data, even if such damage, loss, or corruption is due to Axon negligence. However, regardless of any assistance provided by Axon: (i) Axon will in no way be liable for the accuracy, completeness, success, or results of efforts to restore Agency software or data; (ii) any assistance provided by Axon under this Section is without warranty, express or implied; and (iii) in no event will Axon be liable for loss of, damage to, or corruption of Agency data from any cause.

CONTRACT AMENDMENT

CITY OF TUCSON DEPARTMENT OF PROCUREMENT
255 W. ALAMEDA, 6TH FLOOR, TUCSON, AZ 85701
P.O. BOX 27210, TUCSON, AZ 85726
PHONE: (520) 837-4137 / FAX: (520) 791-4735
Jenn.Myers@tucsonaz.gov
ISSUE DATE: MAY 22, 2017

CONTRACT #151089-01
CONTRACT AMENDMENT NUMBER: FIVE (5)
PAGE 1 of 1
JM/lr
CONTRACT OFFICER: JENN MYERS

BODY WORN CAMERAS

THIS CONTRACT IS AMENDED AS FOLLOWS:

ITEM ONE (1): PRICE LIST

The Price List shall hereby be updated based upon the attached list to reflect new items added to the contract.

ITEM TWO (2): NAME CHANGE

This amendment acknowledges the name change from Taser to Axon.

ALL OTHER PROVISIONS OF THE CONTRACT SHALL REMAIN IN THEIR ENTIRETY.

CONTRACTOR: Axon Enterprise, Inc.

CONTRACTOR HEREBY ACKNOWLEDGES RECEIPT OF AND UNDERSTANDING OF THE ABOVE AMENDMENT.

[Signature]

5/22/17

Signature of person authorized to sign Date

Josh Isner EVP, Global Sales
Name and Title (typed or printed legibly)

Axon Enterprise, Inc
Company Name

17100 N. 85th Street
Address

contracts@axon.com
Email Address

Scottsdale AZ 85255
City State Zip

Contact information for Sales/Account Representative for daily business operations:

Chad Kapler
Name and Title (typed or printed legibly)

800-978-2737
Phone Number

ckapler@axon.com
Email Address

CITY OF TUCSON: _____

THE ABOVE REFERENCED CONTRACT AMENDMENT
IS HEREBY EXECUTED THIS 23rd DAY
OF May, 2017, AT TUCSON, ARIZONA.

[Signature]
for Marcheta Gillespie, CPPO, C.P.M., CPPB, CPM
as Director of Procurement and not personally



17800 N. 85th St. Scottsdale, AZ 85255-6311
 800.978.2737 Toll Free • 480.991.0791 Fax
 www.axon.com • Sales@axon.com

2017 Law Enforcement Agency Pricing – Axon Systems

Axon Flex 2 Hardware and Accessories

Model	Product Description	Agency Price
11528	Axon Flex 2 Camera (online)	\$449.00 ea.
11529	Axon Flex 2 Camera (offline)	\$449.00 ea.
11532	Axon Flex 2 Controller	\$150.00 ea.
11544	Oakley Flak Jacket Kit, Axon Flex 2	\$149.00 ea.
11545	Collar Mount, Axon Flex 2	\$29.00 ea.
11554	Clip, Oakley, Axon Flex 2	\$9.00 ea.
11546	Epaulette Mount, Axon Flex 2	\$29.00 ea.
11547	Ballcap Mount, Axon Flex 2	\$19.00 ea.
11555	Mount, Ballistics Vest, Axon Flex 2	\$19.00 ea.
11548	Universal Helmet Mount, Axon Flex 2	\$19.00 ea.
11549	Tactical SWAT Kit with ARC Rail, Axon Flex 2	\$49.00 ea.
11533	Cable, Coiled, Straight to Right Angle, 48', Axon Flex 2	\$9.00 ea.
11534	USB Sync Cable, Axon Flex 2	\$9.00 ea.
11535	USB Sync Cable, with Wall Charger Axon Flex 2	\$14.95 ea.
11543	Multi-mount Kit, Axon Flex 2	\$199.00 ea.
73082	Wall Wart	\$9.00 ea.

* Camera system, multi-mount, viewer, case.

Axon Body 2 Hardware and Accessories

Model	Product Description	Agency Price
74001	Axon Body 2 Camera System (online)	\$399.00 ea.
74004	Axon Body 2 Camera System (offline)	\$399.00 ea.
74006	Axon Body 2 Battery	\$29.95 ea.
11553	USB Sync Cable	\$10.00 ea.

Axon Body 2 and Flex 2 Controller Mounts **

Model	Product Description	Agency Price
74006	Axon Body 2 Battery	\$29.95 ea.
74018	Z-Bracket, Men's, Axon RapidLock	\$29.95 ea.
74019	Z-Bracket, Women's Axon RapidLock	\$29.95 ea.
74020	Magnet, Flexible, Axon RapidLock	\$29.95 ea.
74021	Magnet, Outerwear, Axon RapidLock	\$29.95 ea.
74022	Small Pocket, 4" (10.1 cm), Axon RapidLock	\$29.95 ea.
74023	Large Pocket, 6" (15.2 cm), Axon RapidLock	\$29.95 ea.
11507	MOLLE Mount, Single, Axon RapidLock	\$29.95 ea.
11508	MOLLE Mount, Double, Axon RapidLock	\$39.95 ea.
11509	Belt Clip Mount, Axon RapidLock	\$29.95 ea.

** Two mounts are included (a la carte) for \$0; \$29.95 for each additional mount.

Axon Signal Hardware & Services

Model	Product Description	Agency Price
70112	Axon Signal unit (1 per car/motor)	\$279.00 ea.
70116	Axon Signal Performance Power Magazine (SPPM)	\$89.99 ea.

Axon Fleet Camera ****

Model	Product Description	Agency Price
Fleet Double Bundle	Axon Fleet Double Camera Bundle includes:*****	\$499.00 ea
74003	Two Axon Fleet Cameras	included
74025	Two Axon Fleet Mount Assemblies	included
70112	One Axon Signal Unit	included

**** Requires a fleet license for the vehicle used with the Axon Fleet product.

***** This is a promotional price currently available for the Axon Fleet system.

Axon Fleet Accessories

Model	Product Description	Agency Price
74025	Axon Fleet Mount Assembly	\$79.95 ea.
74024	Axon Fleet Battery System	\$129.95 ea.
74027	Axon Fleet Dongle	\$14.95 ea.

Axon Dock Hardware

Model	Product Description	Agency Price
11536	1-bay + Core Axon Dock for Axon Flex 2	\$249.00 ea.
11537	6-bay + Core Axon Dock for Axon Flex 2	\$1,495.00 ea.
11538	1-bay for Axon Flex 2	\$249.00 ea.

11539	6-bay for Axon Flex 2	\$1,346.00 ea.
74009	1-bay + Core Axon Dock for Axon Body 2	\$249.00 ea.
74008	6-bay + Core Axon Dock for Axon Body 2	\$1,495.00 ea.
74011	1-bay for Axon Body 2	\$249.00 ea.
74010	6-bay for Axon Body 2	\$1,346.00 ea.
70027	Axon Dock Core, compatible with all 1-bays and 6-bays	\$149.00 ea.
70033	Wall mount, Axon Dock	\$35.00 ea.
70040	Desk plate, Axon Dock	\$35.00 ea.

Customer Care Extended Warranty

Model	Product Description	Agency Price
85070	TASER Assurance Plan Axon Body 2 annual payment	\$204.00 ea.
85054	TASER Assurance Plan Axon Flex 2 annual payment	\$276.00 ea.
85079	TASER Assurance Plan Axon Dock Single Bay annual payment	\$36.00 ea.
87026	TASER Assurance Plan Axon Dock 6-Bay annual payment	\$216.00 ea.
80118	2-Year Extended Warranty Axon Flex 2 Camera	\$299.95 ea.
87029	2-year Extended Warranty Axon Body 2 camera	\$199.95 ea.
87030	2-year Extended Warranty Axon Dock for Axon Body 2, single bay + core	\$129.90 ea.
87031	2-year Extended Warranty Axon Dock for Axon Body 2, 6-bay + core	\$499.90 ea.
80124	2-year Extended Warranty Axon Dock for Axon Flex 2, single bay + core	\$129.90 ea.
80125	2-year Extended Warranty Axon Dock for Axon Flex 2, 6-bay + core	\$499.90 ea.
87032	4-year Extended Warranty Axon Fleet	\$399.00 ea.
87033	2-year Extended Warranty Axon Fleet	\$199.95 ea.

Axon Fleet Router Options

Model	Product Description	Agency Price
11510	Cradlepoint Router - IBR1100LP6	\$660.00 ea.
11511	Cradlepoint - 5 in 1 Cellular, WiFi, GPS Antenna (Black, Bol)	\$220.00 ea.
11512	Cradlepoint - Cellular antenna	\$14.99 ea.
11513	Cradlepoint - WiFi antenna	\$14.99 ea.
11516	Cradlepoint - Enterprise Cloud Manager, 3 yr	\$150.00 ea.
11517	Cradlepoint - Enterprise Cloud Manager, 5 yr	\$250.00 ea.
11518	Cradlepoint - CradleCare, 3 yr	\$175.00 ea.
11519	Cradlepoint - CradleCare, 5 yr	\$275.00 ea.
11520	Cradlepoint - Enterprise Cloud Manager + CradleCare, 3 yr	\$220.00 ea.
11521	Cradlepoint - Enterprise Cloud Manager + CradleCare, 5 yr	\$350.00 ea.
11603	Pepwave Router	\$299.00 ea.

Axon Fleet Wifi Offload Options

Model	Product Description	Agency Price
74064	WI-FI OFFLOAD WIRELESS ACCESS POINT INTEGRATION (5 CAR CONCURRENT UPLOAD)	\$18,745 ea.
74065	WI-FI OFFLOAD WIRELESS ACCESS POINT INTEGRATION (25 CAR CONCURRENT UPLOAD)	\$32,980.00 ea.
74066	WI-FI OFFLOAD NETWORK PROFESSIONAL SERVICES	\$1,000.00 ea.
74067	WI-FI OFFLOAD STORE & FORWARD SOFTWARE LICENSE YEAR 1 PAYMENT	\$600.00 ea.
74074	WI-FI OFFLOAD STORE & FORWARD SERVER HARDWARE	\$3,000.00 ea.

Axon Fleet Installation and Training

Model	Product Description	Agency Price
74063	STANDARD FLEET INSTALLATION (PER VEHICLE)	\$600.00 ea.
80126	FIRST DAY FLEET + SIGNAL INSTALLATION, UP TO 8 CARS	\$3500.00 ea.
80127	EXISTING HARDWARE REMOVAL PER VEHICLE	\$300.00 ea.
80128	FLEET WITH ROUTER INSTALLATION PER VEHICLE	\$500.00 ea.
80129	SIGNAL ONLY OR ROUTER ONLY INSTALLATION PER VEHICLE	\$250.00 ea.
80130	1 DAY, TRAIN THE TRAINER, FLEET INSTALLATION CERTIFICATION,	\$2500.00 ea.
80131	TRAIN INSTALLER OR INSTALLATION FACILITY, PER DAY, PER SITE	\$2500.00 ea.
80132	FIRST DAY, SIGNAL-ONLY, INSTALL ONLY, UP TO 10 CARS	\$2500.00 ea.
80133	FLEET WITHOUT ROUTER INSTALLATION PER VEHICLE	\$350.00 ea.
80134	1 DAY, TRAIN THE INSTALLER, SIGNAL INSTALLATION, PER SITE	\$2000.00 ea.
80135	FLEET + SIGNAL STARTER, 2 DAY, UP TO 8 INSTALL, 1 DAY END USER TRAINING	\$5000.00 ea.
80136	FLEET + SIGNAL FULL SERVICE, 4 DAY, UP TO 24 INSTALL, 1 DAY	\$10,000.00 ea.

Axon Fleet License & Storage Plans (one license per vehicle)*

Model	Product Description	Agency Price
87010	Fleet Basic: 1 year	\$288.00 ea
85731	Fleet Unlimited HD: 1 year payment	\$1,188.00 ea
85738	Fleet Evidence.com Storage (GB): 1 Year	\$0.75 ea.

Evidence.com Services

Model	Product Description	Agency Price
80007	Basic Evidence.com license: 1 year	\$180.00 ea.
80017	Pro Evidence.com license: 1 year	\$468.00 ea.
80057	API Platform Add-On: 1 Year	\$120.00 ea.
80037	Advance User Management Add-on: 1 Year	\$120.00 ea.
80047	CAD/RMS Service Add-On: 1 Year	\$180.00 ea.
80027	Enterprise Bundle Add-on: 1 Year	\$348.00 ea.

80069	Ultimate Evidence.com annual payment*	\$660.00 ea.
80082	Evidence.com Unlimited Plan annual payment*	\$948.00 ea.
80075	Officer Safety Plan annual payment**	\$1,188.00 ea.
85035	Evidence.com storage (GB): 1 year	\$0.75 ea.
85055	Axon Full Service	\$15,000 ea.
85144	Axon Starter	\$2,500 ea.
85146	Axon 1-Day Service	\$2,000 ea.
N.A.	Basic remote support	Free
73094	Viewer (fees vary based on configuration needs, viewer desired, and market price)	Variable

*This license tier is only available for 3-year or 5-year terms

**This license tier is only available for 5-year terms.

Freight Policy Freight is the responsibility of the purchaser. All taxes, duties and customs, where applicable, are the responsibilities of the customer.

Pricing Pricing for Law Enforcement/Correctional Agencies Only. Must be a sworn law enforcement officer to purchase. This is not-to-exceed pricing. Additional discounts may available. Contact Axon for a quote specific to your agency's needs.

Order Lead Time 4 to 6 weeks ARO. ALL SALES ARE FINAL.

Axon Enterprise, Inc.'s Sales Terms and Conditions for Direct Sales to End User Purchasers apply to all sales and are available at <http://www.axon.com/sales-terms-and-conditions>.

Flak Jacket is a trademark of Oakley, Inc.

AXON, Axon, Axon Body 2, Axon Flex, Axon Flex 2, Axon Fleet, Axon Signal, Evidence.com, and TASER are trademarks of Axon Enterprise, Inc., some of which registered in the US and other countries. For more information, visit www.axon.com/legal. All rights reserved. © 2017 TASER Enterprise, Inc.

CONTRACT AMENDMENT

CITY OF TUCSON DEPARTMENT OF PROCUREMENT
255 W. ALAMEDA, 6TH FLOOR, TUCSON, AZ 85701
P.O. BOX 27210, TUCSON, AZ 85726
PHONE: (520) 837-4105 / FAX: (520) 791-4735
lloyd.windle@tucsonaz.gov
ISSUE DATE: Friday, November 04, 2016

CONTRACT AGREEMENT NO: 161089
CONTRACT AMENDMENT NUMBER: FOUR (4)
PAGE 1 of 1
LW/hb
CONTRACT OFFICER: LLOYD WINDLE

BODY WORN CAMERAS AMENDMENT NO. FOUR (4)

THIS SERVICE CONTRACT IS AMENDED AS FOLLOWS:

ITEM ONE (1): Scope Addition

Contractor agrees to provide the City of Tucson's Prosecutors Office with Evidence.com License (Professional and Standard) and Storage at no cost to the City. Details are contained in the Taser Quotation Q-79777-1. Licenses will begin upon the City's signature of this amendment and expire at the expiration of this Contract.

*****END OF AMENDMENT*****

ALL OTHER PROVISIONS OF THE SERVICE AGREEMENT SHALL REMAIN IN THEIR ENTIRETY.

CONTRACTOR: TASER INTERNATIONAL

CONTRACTOR HEREBY ACKNOWLEDGES RECEIPT OF AND UNDERSTANDING OF THE ABOVE AMENDMENT.

[Signature] 11/16/16
Signature of person authorized to sign Date

Josh Isner EVP Global Sales
Name and Title (typed or printed legibly)

TASER International, Inc
Company Name

17800 N. 85th St. ☉
Address

contracts@taser.com
Email Address

Scottsdale AZ 85255
City State Zip

Contact information for Sales/Account Representative for daily business operations:

Jules Veloria Sr. Regional Manager
Name and Title (typed or printed legibly)

602-862-8580
Phone Number

jveloria@taser.com
Email Address

CITY OF TUCSON: _____

THE ABOVE REFERENCED CONTRACT AMENDMENT

IS HEREBY EXECUTED THIS 16th DAY

OF November, 2016, AT TUCSON, ARIZONA.

[Signature]
for Marcheta Gillespie, CPPO, C.P.M., CPPB, CPM
as Director of Procurement and not personally

SERVICE CONTRTACT AMENDMENT

CITY OF TUCSON DEPARTMENT OF PROCUREMENT
255 W. ALAMEDA, 6TH FLOOR, TUCSON, AZ 85701
P.O. BOX 27210, TUCSON, AZ 85726
PHONE: (520) 837-4137 / FAX: (520) 791-4735
Jenn.Myers@tucsonaz.gov
ISSUE DATE: Monday, August 15, 2016

SERVICE AGREEMENT NO: 151089-01
CONTRACT AMENDMENT NUMBER: THREE (3)
PAGE 1 of 2
JM/hb
CONTRACT OFFICER: JENN MYERS

BODY WORN CAMERAS AMENDMENT NO. THREE (3)

THIS SERVICE CONTRACT IS AMENDED AS FOLLOWS:

ITEM ONE (1): RENEWAL

Pursuant to Contract No. 151089, Special Terms and Conditions, Term and Renewal, Section 4, the City is hereby exercising its option to renew the contract for the period of February 1, 2017 through January 31, 2019.

*******END OF AMENDMENT*******

SERVICE CONTRACT AMENDMENT

CITY OF TUCSON DEPARTMENT OF PROCUREMENT
255 W. ALAMEDA, 6TH FLOOR, TUCSON, AZ 85701
P.O. BOX 27210, TUCSON, AZ 85726
PHONE: (520) 837-4137 / FAX: (520) 791-4735
Jenn.Myers@tucsonaz.gov
ISSUE DATE: Monday, August 15, 2016

SERVICE AGREEMENT NO: 151089-01
CONTRACT AMENDMENT NUMBER: THREE (3)
PAGE 2 of 2
JM/hb
CONTRACT OFFICER: JENN MYERS

ALL OTHER PROVISIONS OF THE SERVICE AGREEMENT SHALL REMAIN IN THEIR ENTIRETY.

CONTRACTOR: TASER INTERNATIONAL, INC.

CONTRACTOR HEREBY ACKNOWLEDGES RECEIPT OF AND UNDERSTANDING OF THE ABOVE AMENDMENT.

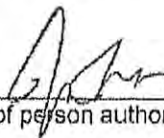
 8/16/16
Signature of person authorized to sign Date

Josh Isner, EVP Global Sales
Name and Title (typed or printed legibly)

TASER International, Inc.
Company Name

17800 N. 85th St. #500
Address

contracts@taser.com
Email Address

Scottsdale AZ 85253
City State Zip

Contact Information for Sales/Account Representative for daily business operations:

Jules Veloria, Sr. Regional Mgr.
Name and Title (typed or printed legibly)

602-862-8880
Phone Number

jveloria@taser.com
Email Address

CITY OF TUCSON: _____

THE ABOVE REFERENCED CONTRACT AMENDMENT IS HEREBY EXECUTED THIS 17th DAY OF August, 2016, AT TUCSON, ARIZONA.

for Nathan Daon
Marcheta Gillespie, CPPO, C.P.M., CPPB, CPM
as Director of Procurement and not personally

CONTRACT AMENDMENT

CITY OF TUCSON DEPARTMENT OF PROCUREMENT
255 W. ALAMEDA, 6TH FLOOR, TUCSON, AZ 85701
P.O. BOX 27210, TUCSON, AZ 85726
(520) 837-4137
ISSUE DATE: JUNE 15, 2016

CONTRACT NO.: 151089
CONTRACT AMENDMENT NO.: TWO (2)
PAGE 1 of 2
JM
CONTRACT OFFICER: JENN MYERS

THIS CONTRACT IS AMENDED AS FOLLOWS:

BODY WORN CAMERAS

ITEM ONE (1): SPECIAL TERMS AND CONDITIONS, COOPERATIVE PURCHASING

Special Terms and Conditions, Cooperative Purchasing, shall hereby be replaced in its entirety with the following:

The resulting Master Agreement from solicitation#151089, Body Worn Cameras shall be for the use of the City of Tucson. In addition, any or all public agencies, including state and local governmental entities, public and private primary, secondary and higher education entities, nonprofit entities and agencies for the public benefit ("Public Agencies"), that have entered into a Cooperative Purchasing Agreement with the City of Tucson's Department of Procurement or registered with National IPA are eligible to participate and purchase at prices stated in the Master Agreement.

See http://www.tucsonprocurement.com/coop_partners.aspx and click on Cooperatives for a list of the public and nonprofit agencies that have currently entered into Cooperative Purchasing Agreements with the City of Tucson. Additionally, this contract is eligible for use by the Strategic Alliance for Volume Expenditures (SAVE) cooperative. See <http://www.maricopa.gov/Materials/PubDocuments/SAVE-members.pdf> for a listing of participating agencies. The parties agree that these lists are subject to change.

Any orders placed to, or services required from, the successful Contractor(s) will be requested by each participating agency. Payment for purchases made under this agreement will be the sole responsibility of each participating agency. The Contractor may negotiate additional expenses incurred as a result of participating agencies' usage of this contract (i.e., freight charges, travel related expenses, etc.). The City shall not be responsible for any disputes arising out of transactions made by others.

ITEM TWO(2): LOCAL PRICE PREFERENCE

As a point of clarification, the following statement is hereby acknowledged:

The Request for Proposal that was used to create this contract included a Local Price Preference policy. However, application of the policy had no impact on the award of the contract.

ITEM THREE (3): PRICING

The Taser International product line is hereby added to the contract per the Attached "2016 Law Enforcement Agency Pricing – Axon Systems." This is not-to-exceed pricing. Additional discounts may be available. Contact TASER for a quote specific to your agency's needs

(This space intentionally left blank.)

CONTRACT AMENDMENT

CITY OF TUCSON DEPARTMENT OF PROCUREMENT
255 W. ALAMEDA, 6TH FLOOR, TUCSON, AZ 85701
P.O. BOX 27210, TUCSON, AZ 85726
(520) 837-4137
ISSUE DATE: JUNE 15, 2016

CONTRACT NO.: 151089
CONTRACT AMENDMENT NO.: TWO (2)
PAGE 2 of 2
JM
CONTRACT OFFICER: JENN MYERS

(This space intentionally left blank.)

ALL OTHER PROVISIONS OF THE CONTRACT SHALL REMAIN IN THEIR ENTIRETY.

CONTRACTOR: TASER International, Inc.

CONTRACTOR HEREBY ACKNOWLEDGES RECEIPT OF
AND UNDERSTANDING OF THE ABOVE AMENDMENT.

[Signature] 7/6/16
Signature of person authorized to sign Date
Josh Isner, EVP Global Sales
Name and Title (typed or printed legibly)
TASER International, Inc.
Company Name
17800 N. 85th St., Scottsdale
Address
Contracts@taser.com
Email Address
Scottsdale AZ 85255
City State Zip

CITY OF TUCSON: _____

THE ABOVE REFERENCED CONTRACT AMENDMENT
IS HEREBY EXECUTED THIS 7th DAY
OF July, 2016, AT TUCSON, ARIZONA.

for Marcheta Gillespie
Marcheta Gillespie, CPPO, C.P.M., CPPB, CPM
as Director of Procurement and not personally

Contact information for Sales/Account Representative
for daily business operations:

Sales Ops
Name and Title (typed or printed legibly)
480-991-0797
Phone Number
Contracts@taser.com
Email Address



17800 N. 85th St. Scottsdale, AZ 85255-6311
 800.978.2737 Toll Free • 480.991.0791 Fax
 www.TASER.com • Sales@TASER.com

2016 Law Enforcement Agency Pricing – Axon Systems

Axon Body 2 Hardware

Model	Product Description	Agency Price
74001	Axon Body 2 Camera System (online)	\$399.00 ea.
74004	Axon Body 2 Camera System (offline)	\$399.00 ea.

Axon Body 2 Accessories *

Model	Product Description	Agency Price
74006	Axon Body 2 Battery	\$29.95 ea.
74018	Z-Bracket, Men's, Axon Body 2	\$29.95 ea.
74019	Z-Bracket, Women's Axon Body 2	\$29.95 ea.
74020	Magnet, Flexible, Axon Body 2	\$29.95 ea.
74021	Magnet, Outerwear, Axon Body 2	\$29.95 ea.
74022	Small Pocket, 4" (10.1 cm), Axon Body 2	\$29.95 ea.
74023	Large Pocket, 6" (15.2 cm), Axon Body 2	\$29.95 ea.

* Two mounts are included (a la carte) for \$0; \$29.95 for each additional mount.

Axon Flex Hardware

Model	Product Description	Agency Price
73096	Axon Flex Camera System (Camera, Controller, and product model 73060) **	\$599.00 ea.
73097	Axon Flex Camera System, Offline (Camera, Controller, and product model 73060) **	\$599.00 ea.
73034	Oakley Flak Jacket Kit, Axon Flex	\$149.95 ea.

** This is a promotional price currently available for the Axon Flex system.

Axon Signal Hardware & Services

Model	Product Description	Agency Price
70112	Axon Signal unit (1 per car/motor)	\$279.00 ea.
70113	Axon Flex Camera System Signal equipped (Signal version of 73096)	\$688.00 ea.
70114	Axon Flex Camera System Signal equipped, Offline (Signal version of 73097)	\$688.00 ea.
70115	Axon Flex Controller Signal equipped	\$239.00 ea.
Service	Signal installation and/or training	Variable

Axon Fleet Cameras ***

Model	Product Description	Agency Price
Fleet Single Bundle	Axon Fleet Single Camera Bundle includes:****	\$399.00 ea.
74003	One Axon Fleet Camera****	included
74025	One Axon Fleet Mount Assembly	included
70112	One Axon Signal Unit	included
Fleet Double Bundle	Axon Fleet Double Camera Bundle includes:****	\$499.00 ea.
74003	Two Axon Fleet Cameras	included
74025	Two Axon Fleet Mount Assemblies	included
70112	One Axon Signal Unit	included

*** Requires a fleet license for the vehicle used with the Axon Fleet product.

**** This is a promotional price currently available for the Axon Fleet system.

Axon Fleet Accessories

Model	Product Description	Agency Price
74025	Axon Fleet Mount Assembly	\$79.95 ea.

Title: AXON Law Enforcement Agency Pricing
 Department: Sales/Customer Service
 Version: 1.0
 Release Date: 1/6/2016

CONTRACT AMENDMENT

CITY OF TUCSON DEPARTMENT OF PROCUREMENT
255 W. ALAMEDA, 6TH FLOOR, TUCSON, AZ 85701
P.O. BOX 27210, TUCSON, AZ 85726
(520) 837-4137
ISSUE DATE: MARCH 30, 2016

CONTRACT NO.: 151089
CONTRACT AMENDMENT NO.: ONE (1)
PAGE 3 of 3
JM/sa
CONTRACT OFFICER: JENN MYERS

contracts@taser.com

Email Address



February 6, 2015

CITY OF
TUCSON
DEPARTMENT OF
PROCUREMENT

Maureen Hanrahan
Sales Operations Coordinator
TASER International, Inc
17800 N 85th St.
Scottsdale, AZ 85255

Via email: Maureen@taser.com

RE: Contract No. 151089, Body Worn Cameras

Dear Ms. Hanrahan:

Congratulations! The City of Tucson has awarded to your firm the above referenced contract. The effective date for the contract will be February 2, 2015 through February 1, 2016.

A copy of the contract, the Designation of Contract Representative memorandum outlining the duties and responsibilities of the representative as they relate to this contract, and a purchase order are enclosed.

The City looks forward again to working with your organization. If you have any questions, please feel free to contact me. I can be reached at (520) 837-4132.

Sincerely,

Gillian Needham
Senior Contract Officer
Gillian.Needham@tucsonaz.gov

GN/sa

Enclosures: 3



NOTICE OF INTENT TO AWARD

CITY OF
TUCSON

DEPARTMENT OF
PROCUREMENT

January 22, 2015

Maureen Hanrahan
Sales Operations Coordinator
TASER International, Inc
17800 N 85th st
Scottsdale, AZ 85255

Via email: Maureen@taser.com

Re: Request for Proposal #151089, Body Worn Cameras

Dear Ms. Hanrahan:

It is the City's intent to accept your bid for the above-referenced solicitation.

This Notice of Intent to Award is not a contract and does not establish any contractual relationship. The contract is not deemed to be executed until it is signed by the City's Director of Procurement and approved as to form by the City Attorney.

Sincerely,

Gillian Needham
Senior Contract Officer

GN/sa

Contract #151089

Body Worn Cameras

Table of Contents

- 1. Taser International Best and Final Offer**
- 2. City's Request for Best and Final Offer**
- 3. Taser International's response to
RFP #151089**
- 4. RFP #151089**

1. Taser International Best and Final Offer

EVIDENCE.COM™

EVIDENCE.com and RMS Integration ROI Analysis

Current Costs		
	Minutes per video spent manually adding metadata	1.5
	Videos recorded per shift	10
	Shifts worked per month	16
	Cost of an officer's hour	\$ 50
	Monthly cost of manually adding metadata per officer	\$ 200
	Annual cost of manually adding metadata per officer	\$ 2,400
Integration Costs		
	Monthly price of integration license per officer	\$ 20
	Leader's Pricing Program discount	25%
	Monthly cost of license per officer for Danville PD	\$ 15
	Annual cost of license per officer	\$ 180
Return On Investment		
	Number of officers	114
	Annual cost of manually add metadata	\$ 273,600
	Annual cost of integration licenses	\$ 20,520
	Annual Savings from Integration	\$ 253,080
	Annualized return on investment	1233%
	Weeks to recoup annual investment	4
Total Savings		
	Years of integration	5
	Total cost of manually adding metadata	\$ 1,368,000
	Total cost of integration	\$ 102,600
	Total Savings from integration	\$ 1,265,400

RMS Integration from EVIDENCE.com

Easily tag your agency's videos with correct info and data

RMS Integration works by taking information from your Records Management System and correlating it with your videos on EVIDENCE.com. Benefits include:



Greater Accuracy

Adds Incident ID, Category and Location to videos automatically

Avoids the misspellings and incomplete info of manual entry

Makes it easier to search and retrieve evidence later



Increased Efficiency

Frees officers from manual video tagging and saves time

Requires minimal involvement from IT staff

Can work with any system without involving RMS vendors



Cost Effectiveness

Saves up to \$200 per officer per month in productivity costs

Per-user pricing scales with the number of officers uploading

Can be added to existing contracts anytime

FAQs

About RMS Integration

Q. What is EVIDENCE.com RMS Integration?

A. We take information exported from the agency's Record Management System and correlate it with videos on EVIDENCE.com. This allows us to automatically tag AXON® videos with the correct:

- Incident ID
- Category
- Location

Officers no longer have to spend valuable time entering this data after each incident, and supervisors no longer have to search extensively for untagged or incorrectly tagged videos.

Q. Why is an RMS Integration valuable?

A. Video evidence can be invaluable—as long as it's easily logged and found. We've observed that when busy officers manually tag videos with metadata, only 80% are tagged with the information necessary to manage the evidence later, and some may be tagged incorrectly due to officers mistyping a value. RMS Integration automates the process to ensure you have complete, correct information about each piece of video evidence.

Tagging videos correctly takes officers time, about 3 minutes per video. If they record 5 videos per shift, and work 16 shifts per month, that means each officer is spending 4 hours per month entering metadata. Some agencies estimate that automating this process could help them save up to \$200 in productivity costs for every officer, every month—that's on top of the efficiency gains from implementing AXON cameras and EVIDENCE.com in the first place.

Q. How does it work?

A. We can integrate with any RMS, and do not need to involve your RMS vendor in the process. For your agency there are only 2 steps:

1. Generate a regularly scheduled export (XML or CSV file) of your RMS database with the relevant information
2. Install a small application behind your firewall to encrypt the exported file and send it to EVIDENCE.com, where customized software automatically correlates the correct metadata with the correct videos

When officers next log in, their videos will all be automatically tagged with the correct data. When supervisors search for videos, they can be confident that their results are comprehensive. Generally an RMS Integration takes only 4–8 weeks to implement, although this depends on coordination with the agency's IT department.

Q. How much does it cost?

A. RMS Integration uses a license model, so there is a per-user monthly fee. The total cost for an agency will vary based on the number of users uploading AXON videos. Your TASER Sales Rep can provide you with an accurate quote and notify you of any current promotions. RMS Integration can be added to an agency's current EVIDENCE.com contract at any time.

Q. How do I get started or learn more?

A. If you are interested in an EVIDENCE.com RMS Integration for your agency, or just want to learn more, please contact your TASER International Sales Representative or visit TASER.com/rms.

RMS Integration

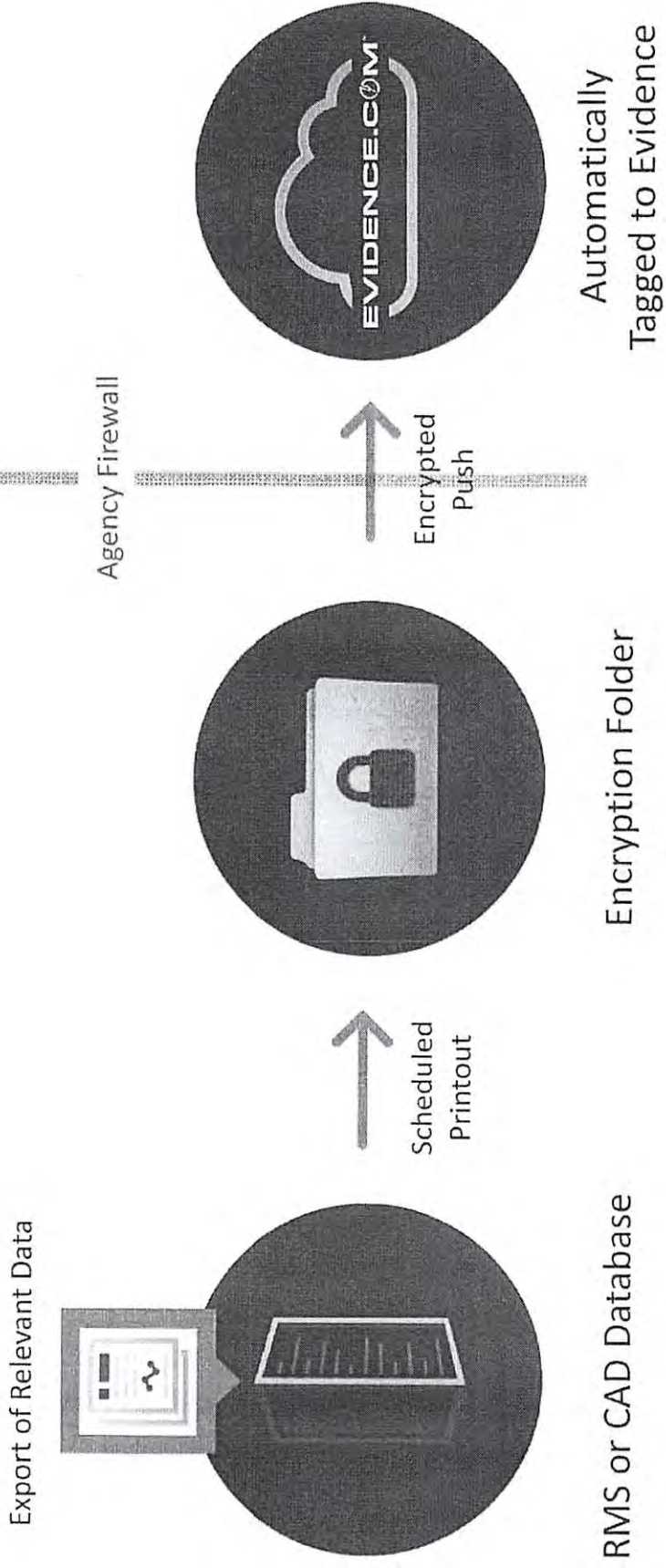

TASER International
Protect Truth

17800 N 85th St.
Scottsdale, Arizona 85255
United States
Phone: (800) 978-2737
Fax:

Joe Puglia
(520) 791-4467
joe.puglia@tucsonaz.gov



Quotation
Quote: Q-22240-1
Date: 1/9/2015 8:48 AM
Quote Expiration: 3/31/2015
Contract Start Date*: 4/20/2015
Contract Term: 5 years

Bill To:
Tucson Police Dept. - AZ
270 S Stone Avenue
Tucson, AZ 85701
US

Ship To:
Joe Puglia
Tucson Police Dept. - AZ
270 S Stone Avenue
Tucson, AZ 85701
US

SALESPERSON	PHONE	EMAIL	DELIVERY METHOD	PAYMENT METHOD
Laurie Bain		lbain@taser.com	Fedex - Ground	Net 30

*Note this will vary based on the shipment date of the product.

Year One Due 2015

QTY	ITEM #	DESCRIPTION	UNIT PRICE	Total Before Discount	DISC (\$)	NET TOTAL
70	85097	EVIDENCE COM INTEGRATION LICENSE 1 YEAR	240.00	USD 16,800.00	USD 4,200.00	USD 12,600.00
Year One Due 2015 Total:						USD 16,800.00
Year One Due 2015 Net Price:						USD 12,600.00

Year Two Due 2016

QTY	ITEM #	DESCRIPTION	UNIT PRICE	Total Before Discount	DISC (\$)	NET TOTAL
70	85097	EVIDENCE COM INTEGRATION LICENSE 1 YEAR	240.00	USD 16,800.00	USD 4,200.00	USD 12,600.00
Year Two Due 2016 Total:						USD 16,800.00
Year Two Due 2016 Net Price:						USD 12,600.00

Year Three Due 2017

QTY	ITEM #	DESCRIPTION	UNIT PRICE	Total Before Discount	DISC (\$)	NET TOTAL
70	85097	EVIDENCE COM INTEGRATION LICENSE 1 YEAR	240.00	USD 16,800.00	USD 4,200.00	USD 12,600.00
Year Three Due 2017 Total:						USD 16,800.00
Year Three Due 2017 Net Price:						USD 12,600.00

Year Four Due 2018

QTY	ITEM #	DESCRIPTION	UNIT PRICE	Total Before Discount	DISC (\$)	NET TOTAL
70	85097	EVIDENCE COM INTEGRATION LICENSE 1 YEAR	240.00	USD 16,800.00	USD 4,200.00	USD 12,600.00
Year Four Due 2018 Total:						USD 16,800.00
Year Four Due 2018 Net Price:						USD 12,600.00

Year Five Due 2019

QTY	ITEM #	DESCRIPTION	UNIT PRICE	Total Before Discount	DISC (\$)	NET TOTAL
70	85097	EVIDENCE COM INTEGRATION LICENSE 1 YEAR	240.00	USD 16,800.00	USD 4,200.00	USD 12,600.00
Year Five Due 2019 Total:						USD 16,800.00
Year Five Due 2019 Net Price:						USD 12,600.00

Subtotal	USD 63,000.00
Estimated Shipping & Handling Cost	USD 12.96
Estimated Tax	USD 39,600.00

TASER International
Protect Truth

17800 N 85th St.
Scottsdale, Arizona 85255
United States
Phone: (800) 978-2737
Fax:

Joe Puglia
(520) 791-4467
joe.puglia@tucsonaz.gov

Bill To:
Tucson Police Dept. - AZ
270 S Stone Avenue
Tucson, AZ 85701
US

Ship To:
Joe Puglia
Tucson Police Dept. - AZ
270 S Stone Avenue
Tucson, AZ 85701
US



Quotation
Quote: Q-22221-1
Date: 1/9/2015 1:25 PM
Quote Expiration: 3/31/2015
Contract Start Date*: 4/20/2015
Contract Term: 5 years

SALESPERSON	PHONE	EMAIL	DELIVERY METHOD	PAYMENT METHOD
Laurie Bain		lbain@taser.com	Fedex - Ground	Net 30

*Note this will vary based on the shipment date of the product.

Year One Due 2015

QTY	ITEM #	DESCRIPTION	UNIT PRICE	Total Before Discount	DISC (\$)	NET TOTAL
70	85123	EVIDENCE COM UNLIMITED LICENSE YEAR 1 PAYMENT	948.00	USD 66,360.00	USD 0.00	USD 66,360.00
28	73030	CAMERA SYSTEM, AXON FLEX	599.00	USD 16,772.00	USD 0.00	USD 16,772.00
14	73034	OAKLEY FLAK JACKET KIT, FLEX	149.95	USD 2,099.30	USD 0.00	USD 2,099.30
28	73011	EPAULETTE MOUNT, FLEX		USD 0.00	USD 0.00	USD 0.00
28	73036	CONTROLLER, HOLSTER, BELT CLIPS, FLEX		USD 0.00	USD 0.00	USD 0.00
42	73002	CAMERA SYSTEM, AXON BODY SPARE	399.00	USD 16,758.00	USD 0.00	USD 16,758.00
12	70026	EVIDENCE COM DOCK, AXON SIX BAY	1495.00	USD 17,940.00	USD 0.00	USD 17,940.00
70	85079	TASER ASSURANCE PLAN ETM: EVIDENCE COM DOCK ANNUAL PAYMENT	36.00	USD 2,520.00	USD 0.00	USD 2,520.00
1,400	85110	EVIDENCE COM INCLUDED STORAGE		USD 0.00	USD 0.00	USD 0.00
1	73039	CAMERA SYSTEM, AXON FLEX SPARE	599.00	USD 599.00	USD 599.00	USD 0.00
2	73002	CAMERA SYSTEM, AXON BODY SPARE	399.00	USD 798.00	USD 798.00	USD 0.00
1	85055	PREMIUM PLUS SERVICE	15000.00	USD 15,000.00	USD 7,500.00	USD 7,500.00
Year One Due 2015 Total:						USD 138,846.30
Year One Due 2015 Net Price:						USD 129,949.30

Year Two Due 2016

QTY	ITEM #	DESCRIPTION	UNIT PRICE	Total Before Discount	DISC (\$)	NET TOTAL
70	85124	EVIDENCE COM UNLIMITED LICENSE YEAR 2 PAYMENT	948.00	USD 66,360.00	USD 0.00	USD 66,360.00
70	85079	TASER ASSURANCE PLAN ETM EVIDENCE COM DOCK ANNUAL PAYMENT	36.00	USD 2,520.00	USD 0.00	USD 2,520.00
1,400	85110	EVIDENCE COM INCLUDED STORAGE		USD 0.00	USD 0.00	USD 0.00
Year Two Due 2016 Total:						USD 68,880.00
Year Two Due 2016 Net Price:						USD 68,880.00

Year Three Due 2017

QTY	ITEM #	DESCRIPTION	UNIT PRICE	Total Before Discount	DISC (\$)	NET TOTAL
70	85125	EVIDENCE COM UNLIMITED LICENSE YEAR 3 PAYMENT	948.00	USD 66,360.00	USD 0.00	USD 66,360.00
70	85079	TASER ASSURANCE PLAN ETM EVIDENCE COM DOCK ANNUAL PAYMENT	36.00	USD 2,520.00	USD 0.00	USD 2,520.00
1,400	85110	EVIDENCE COM INCLUDED STORAGE		USD 0.00	USD 0.00	USD 0.00
Year Three Due 2017 Total:						USD 68,880.00
Year Three Due 2017 Net Price:						USD 68,880.00

Year Four Due 2018

QTY	ITEM #	DESCRIPTION	UNIT PRICE	Total Before Discount	DISC (\$)	NET TOTAL
70	85126	EVIDENCE COM UNLIMITED LICENSE YEAR 4 PAYMENT	948.00	USD 66,360.00	USD 0.00	USD 66,360.00
70	85079	TASER ASSURANCE PLAN ETM EVIDENCE COM DOCK ANNUAL PAYMENT	36.00	USD 2,520.00	USD 0.00	USD 2,520.00
1,400	85110	EVIDENCE COM INCLUDED STORAGE		USD 0.00	USD 0.00	USD 0.00
Year Four Due 2018 Total:						USD 68,880.00
Year Four Due 2018 Net Price:						USD 68,880.00

Year Five Due 2019

QTY	ITEM #	DESCRIPTION	UNIT PRICE	Total Before Discount	DISC (\$)	NET TOTAL
70	85127	EVIDENCE COM UNLIMITED LICENSE YEAR 5 PAYMENT	948.00	USD 66,360.00	USD 0.00	USD 66,360.00
70	85079	TASER ASSURANCE PLAN ETM EVIDENCE COM DOCK ANNUAL PAYMENT	36.00	USD 2,520.00	USD 0.00	USD 2,520.00
1,400	85110	EVIDENCE COM INCLUDED STORAGE		USD 0.00	USD 0.00	USD 0.00
Year Five Due 2019 Total:						USD 68,880.00
Year Five Due 2019 Net Price:						USD 68,880.00

Subtotal	USD 405,469.30
Estimated Shipping & Handling Cost	USD 589.26
Estimated Tax	USD 25,500.27



17800 N. 85th St. Scottsdale, AZ 85255-6311
 800.978.2737 Toll Free • 480.991.0791 Fax
 www.TASER.com • Sales@TASER.com

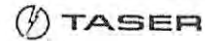

2015 Law Enforcement Agency Pricing – AXON® Systems

AXON body Hardware

Model	Product Description	Agency Price
73002	AXON body Camera	\$399.00 ea.
73066	AXON body Camera Full Solution Kit*	\$649.95 ea.

*Includes several AXON mounts and a Moto G touch mobile digital device.

AXON body Accessories

Model	Product Description	Agency Price
73075	Standard Uniform Clip Holster	\$29.95 ea.
73076	Mini Alligator Clip Holster	\$29.95 ea.
73077	Belt Clips Holster	\$29.95 ea.
73078	Holster, Z-Bracket, HW	\$29.95 ea.
73079	Holster, Z-Bracket, VELCRO	\$29.95 ea.
73089	Pocket Mount Holster	\$29.95 ea.

AXON flex® Hardware

Model	Product Description	Agency Price
73030	AXON flex Camera System (Camera, Controller, Cable straight to right angle 48" (73023), Coiled cable straight to right angle (73060), USB Sync Cable w/ Wall Charger (73004) **	\$599.00 ea.
73055	AXON flex Camera System, Offline **	\$599.00 ea.
73061	AXON flex Full Solution Kit ** †	\$1,113.55 ea.
73066	AXON flex Full Solution Kit, Offline ** †	\$1,113.55 ea.
73092	Motorola Moto G	\$199.00 ea.
73034	Oakley Flak Jacket Kit, flex	\$149.95 ea.

** This is a promotional price currently available for the AXON flex system.
 † Includes several AXON mounts and a Moto G mobile digital device.

EVIDENCE.com Dock Hardware

Model	Product Description	Agency Price
70026	6-bay + Core EVIDENCE.com Dock	\$1,495.00 ea.
70023	1-bay + Core EVIDENCE.com Dock	\$249.00 ea.
70028	Individual bay EVIDENCE.com Dock	\$249.00 ea.

Customer Care Extended Warranty

Model	Product Description	Agency Price
70032 & 70030	EVIDENCE.com Dock, 2-YEAR EXTENDED WARRANTY, 6-BAY	\$499.90 ea.
70031 & 70030	EVIDENCE.com Dock 2-YEAR EXTENDED WARRANTY, SINGLE BAY	\$129.90 ea.
73033	AXON flex kit 2-YEAR EXTENDED WARRANTY	\$299.95 ea.
73074	AXON body cam 2-YEAR EXTENDED WARRANTY	\$199.95 ea.

EVIDENCE.com Services

Model	Product Description	Agency Price
87001	Basic EVIDENCE.com license: 1 year	\$180.00 ea.
88001	Standard EVIDENCE.com license: 1 year	\$300.00 ea.
89001	Pro EVIDENCE.com license: 1 year	\$488.00 ea.
85078	Ultimate EVIDENCE.com annual payment	\$660.00 ea.
85035	EVIDENCE.com storage (GB): 1 year	\$1.50 ea.

Title: AXON Law Enforcement Agency Pricing
 Department: Sales/ Customer Service
 Version: 1.0
 Release Date: 12/3/2014



EVIDENCE.com Services

Model	Product Description	Agency Price
85054	TASER Assurance Plan AXON flex annual payment	\$276.00 ea.
85070	TASER Assurance Plan AXON body annual payment	\$204.00 ea.
85079	TASER Assurance Plan EVIDENCE.com Dock annual payment (based on the number of cameras purchased)	\$36.00 ea.
85055	Premium Plus Package	\$15,000 ea.
85056	Premium Package	\$7,500 ea.
N.A.	Basic remote support	Free
85014	A La Carte Package	\$2,000.00 ea. day

AXON flex Accessories

Model	Product Description	Agency Price
73004	USB Synch Cable w/ Wall Charger	\$14.95 ea.
73008	Oakley Clip	\$19.95 ea.
73009	Collar/Versatile/Cap Mount	\$29.95 ea.
73088	Ratchet Collar/Versatile/Cap Mount	\$29.95 ea.
73062	Ball Cap Mount	\$29.95 ea.
73010	Low Rider Headband	\$49.95 ea.
73058	Low Rider Headband, Large	\$54.95 ea.
73006	Controller Holster, flex, Standard Uniform Clip	\$29.95 ea.
73035	Controller Holster, flex, Mini Alligator Clip	\$29.95 ea.
73036	Controller Holster, flex, Belt Clips	\$29.95 ea.
73011	Epaulette Mount	\$19.95 ea.
73013	Helmet Mount	\$19.95 ea.
73090	Helmet Mount, Ratchet, Shoxi	\$19.95 ea.
73091	Helmet Mount, Ratchet, H/C	\$19.95 ea.
73020	Universal Magnet Clip	\$7.95 ea.
73021	Multi-Mounting Kit, Flex (Low Rider headband, Collar mount, Epaulette mount, Oakley kit)	\$199.95 ea.
73059	Ballistic Vest Mount, Rotating	\$19.95 ea.
73022	Cable, Straight to Right Angle, 18"	\$5.95 ea.
73005	Cable, Straight to Right Angle, 36"	\$5.95 ea.
73023	Cable, Straight to Right Angle, 48"	\$5.95 ea.
73025	Cable, Straight to Straight, 36"	\$5.95 ea.
73026	Cable, Straight to Straight, 48"	\$5.95 ea.
73027	Cable, Right Angle to Right Angle, 18"	\$5.95 ea.
73028	Cable, Right Angle to Right Angle, 36"	\$5.95 ea.
73029	Cable, Right Angle to Right Angle, 48"	\$5.95 ea.
73060	Cable, Coiled, Straight to Right Angle 48"	\$12.95 ea.
73081	TASER CAM™ HD/AXON Camera Universal Charger w/U.S. and International Adaptors	\$14.95 ea.

Freight Policy Freight is the responsibility of the purchaser. All orders are shipped F.O.B. Scottsdale, AZ via Fed-Ex ground and billed as a separate line item on invoice. All taxes, duties and customs, where applicable, are the responsibilities of the customer.

Pricing Pricing for Law Enforcement/Correctional Agencies Only. Must be a sworn law enforcement officer to purchase.

Order Lead Time 4 to 6 weeks ARO. ALL SALES ARE FINAL.

For delivery status or information on how to place an order, call our sales department at 800-978-2737, fax: 480-991-0781

TASER International, Inc.'s Sales Terms and Conditions for Direct Sales to End User Purchasers apply to all sales and are available at <http://www.taser.com/sales-terms-and-conditions>.

Flak Jacket is a trademark of Oakley, Inc. Motorola is a trademark of Motorola Trademark Holdings, LLC, and VELCRO is a trademark of Velcro Industries B.V.

AXON, AXON flex, TASER and are trademarks of TASER International, Inc. registered in the USA. All rights reserved. © 2014 TASER International, Inc.



17800 N. 85th St. Scottsdale, AZ 85255-6311
 Toll Free: 800.978.2737 • Fax: 480.991.0791
 www.TASER.com • Sales@TASER.com

2015 TASER® X2™ CEW Law Enforcement Pricing

Model	Product Description	Agency Price
-------	---------------------	--------------

X2 Conducted Electrical Weapons (Handle Only without Power Magazine, choose one)

22002	Black X2 CEW	\$1,029.95 ea
22003	Yellow X2 CEW	\$1,029.95 ea

X2 Power Magazines (Choose one)

22010	Performance Power Magazine (PPM)	\$54.50 ea
22012	Tactical Performance Power Magazine (TPPM)	\$54.50 ea

X2 Power Magazine (Optional)

22011	Automatic Shut-Down Power Magazine (APPM)	\$65.85 ea
-------	---	------------

Optional Accessories

X2 Holsters

22501	Holster, X2, Right Hand, Blackhawk!	\$65.85 ea
22504	Holster, X2, Left Hand, Blackhawk!	\$65.85 ea

Customer Care Extended Warranty

22014	4-year Extended Warranty	\$318.25 ea
-------	--------------------------	-------------

X2 Smart™ Cartridges**

22150	15' Live Smart Cartridge	\$29.50 ea
22151	25' Live Smart Cartridge	\$31.50 ea
22152	35' Live Smart Cartridge	\$32.70 ea
22155	Inert Simulator 25' Smart Cartridge	\$43.00 ea
22157	25' Training Smart Cartridge (Blue Blast Door/Non-conductive)	\$30.60 ea

TASER CAM™ HD Recorders

26810	TASER CAM HD	\$530.40 ea
26820	TASER CAM HD with Automatic Shut-Down (AS) Feature	\$556.95 ea
26762	TASER CAM HD USB download kit	\$15.40 ea
26763	TASER CAM HD 4-Year Extended Warranty	\$154.45 ea
26764	TASER CAM HD Replacement Battery	\$52.95 ea

X2 Dataport Download Kits

22013	Kit, Dataport Download, USB, X2	\$184.75 ea
-------	---------------------------------	-------------

HOGUE HANDALL Grips

22016	Grip, CEW, Hogue, packaged	\$15.25 ea
-------	----------------------------	------------

**15-foot, 25-foot, and 35-foot X2 cartridges are compatible with TASER® X2 and X3® CEWs. X3 cartridges (part numbers 33100, 33101, 33102, 33103, 33104, and 33106) are NOT compatible with the X2 CEW.

TASER International, Inc.'s Sales Terms and Conditions for Direct Sales to End User Purchasers apply to all sales and are available at <http://www.taser.com/sales-terms-and-conditions>.

For delivery status or to place an order, call TASER's sales department at 800-978-2737 or fax the order to: 480-991-0791.

BLACKHAWK! is a trademark of BLACKHAWK! Products Group. HANDALL is a trademark of Hogue, Inc., and HOGUE is a registered trademark of Hogue, Inc. Smart, TASER CAM, X2 and Protect Life are trademarks of TASER International, Inc., and TASER, X3, X2 and Design, and are trademarks of TASER International, Inc., registered in the USA. All rights reserved. © 2014 TASER International, Inc.



17800 N. 85th St. Scottsdale, AZ 85255-6311

Toll Free: 800.978.2737 • Fax: 480.991.0791

www.TASER.com • Sales@TASER.com

2015 TASER® X26P™ CEW Law Enforcement Pricing

Model	Product Description	Agency Price
X26P Conducted Electrical Weapons (CEW Only without Power Magazine, choose one)		
11002	Black X26P CEW, class III LASER	\$899.95 ea
11003	Yellow X26P CEW, class III LASER	\$899.95 ea
X26P Power Magazines (Choose one)		
22010	Performance Power Magazine (PPM)	\$54.50 ea
22012	Tactical Performance Power Magazine (TPPM)	\$54.50 ea
11010	eXtended Performance Power Magazine (XPPM)	\$63.50 ea
X26P Power Magazine (Optional)		
22011	Automatic Shut-Down Power Magazine (APPM)	\$65.85 ea
11015	eXtended Automatic Shut-Down Power Magazine (XAPPM)	\$67.05 ea
Optional Accessories		
X26P Holsters		
11501	Holster, X26P, Right Hand, Blackhawk!	\$53.25 ea
11504	Holster, X26P, Left Hand, Blackhawk!	\$53.25 ea
Customer Care Extended Warranty		
11004	4-year Extended Warranty	\$277.95 ea
TASER CAM™ HD Recorders		
26810	TASER CAM HD	\$530.40 ea
26820	TASER CAM HD with Automatic Shut-Down (AS) Feature	\$556.95 ea
26762	TASER CAM HD USB download kit	\$15.40 ea
26763	TASER CAM HD 4-Year Extended Warranty	\$154.45 ea
26764	TASER CAM HD Replacement Battery	\$52.95 ea
Dataport Download Kits		
22013	Kit, Dataport Download, USB	\$164.75 ea
HOGUE HANDALL Grips		
22018	Grip, CEW, Hogue, packaged	\$15.25 ea
X26P Cartridges		
34200	15' Field Use ¹	\$22.20 ea
44200	21' Field Use	\$24.25 ea
44203	25' XP™ Field Use	\$27.35 ea
44205	21' Non-Conductive Sim	\$23.60 ea

¹ The 15-foot cartridges are recommended for training, due to their relatively short range. However, these 15-foot cartridges are conductive, and must NOT be used against a person wearing a Sim Suit.



2015 TASER X26™ Accessories Law Enforcement Pricing

Model	Product Description	Agency Price
<i>X26 Power Magazines</i>		
26700	Digital Power Magazine (DPM)	\$36.80 ea
26701	eXtended Digital Power Magazine (XDPM)	\$41.95 ea
26702	Controlled Digital Power Magazine (CDPM)	\$57.40 ea
26703	CDPM Start Up Kit	\$197.30 ea
<i>X26 Holsters</i>		
44952	Holster, X26, Right Hand, Blade-Tech	\$36.00 ea
44953	Holster, X26, Left Hand, Blade-Tech	\$36.00 ea
44972	Holster, X26, Right Hand, BLACKHAWK!	\$36.00 ea
44973	Holster, X26, Left Hand, BLACKHAWK!	\$36.00 ea

TASER International, Inc.'s Sales Terms and Conditions for Direct Sales to End User Purchasers apply to all sales and are available at <http://www.taser.com/sales-terms-and-conditions>.

For delivery status or to place an order, call TASER's sales department at 800-978-2737 or fax the order to: 480-991-0791.

BLACKHAWK! is a trademark of BLACKHAWK! Products Group. HIGHLAND is a trademark of Hogue, Inc. and HESQUE is a trademark of Hogue, Inc.

TASER, CAM, X26, X26P and Design, X26, XP and Protect Life are trademarks of TASER International, Inc. and TASER and are trademarks of TASER International, Inc. registered in the USA. All rights reserved. © 2014 TASER International, Inc.

2. City's Request for Best and Final Offer

December 15, 2014

Sent via electronic mail, this day

Maureen Hanrahan
TASER International, Inc
17800 N. 85th St.
Scottsdale, AZ 85255
Email: Maureen@taser.com

**Subject: Request for Proposal No. 151089 Body Worn Cameras –
Notice of Intent to Negotiate**

Dear Ms. Hanrahan:

The City of Tucson has completed the evaluation of submittals received in response to the subject solicitation. Based upon the recommendation of the evaluation committee, the City is inviting **Taser International** to enter into negotiations.

The City has reviewed **Taser International** proposal and would like to discuss the following points with representatives of **Taser International** on **Friday December 19, 2014 at 2:00 PM at Tucson Police Department Headquarters, 270 S. Stone Ave.**

1. Pricing for cameras and mounting options
2. Storage fees with proposed ideas for limiting amount of cloud based storage
3. Additional Services
 - Relationship with Intergraph
 - Warranty and future replacement
 - Pont of View mounting- universal mounting option release date

This Notice of Intent to Negotiate is not an intent to award a contract and does not establish any contractual relationship between **Taser International** and the City. Its intent is to notify the affected parties that the City will engage in negotiations with **Taser International**. In the event that the City is not able to negotiate a satisfactory contract with **Taser International**, the City will formally terminate negotiations and may enter into subsequent negotiations with the next most qualified firm.

If you should have any questions regarding the items above, please contact me at (520) 837-4132 or Gillian.Needham@tucsonaz.gov. I look forward to meeting you on **Friday the 19th of December.**

Sincerely,



Gillian Needham
Contract Officer

**3. Taser International's response to
RFP #140922**

Original



TASER

CITY OF TUCSON, AZ

**BODY WORN CAMERAS AND
STORAGE SYSTEM FOR THE
TUCSON POLICE DEPARTMENT**

RFP # 151089

SUBMITTED BY:

TASER International
17800 North 85th Street
Scottsdale, AZ, 85255
800.978.2737
October 15, 2014

TABLE OF CONTENTS

Proposal Evaluation Requirements.....	3
A. Method of Approach	3
B. Qualifications and Experience	17
C. Price Proposal.....	22
Axon flex and evidence.com Introductions and Summary	27
Proposer’s Capabilities.....	32
Your TASER Account Manager/ Point of Contact	33
AXON flex Features, Benefits, and Added Value	35
EVIDENCE.com – Simple, Turn-Key Cloud Software with Scalability.....	39
Video Management Backend System	40
EVIDENCE.com: Advanced Features	50

Attachments

Appendix A – Sample Reports	
Appendix B – Business and Development Plan	
Completed RFP Pages, forms and signatures.....	Attachment 1
TASER flex and EVIDENCE.com Quote Q-18016-1.....	Attachment 2
TASERs Exceptions/Deviations.....	Attachment 3
Project Plan.....	Attachment 4
Sample Retention Guide.....	Attachment 5
TASER Sales Terms and Conditions.....	Attachment 6
AXON TAP Sales Terms and Conditions.....	Attachment 7
TASER Warranty Documents.....	Attachment 8
AXON Pricing.....	Attachment 9
AXON flex Specification Sheets.....	Attachment 10
Master Services Agreement	Attachment 11
Professional Services Agreement.....	Attachment 12
Confidential References–In marked envelope in binders and separate CD in Original Binder	

PROPOSAL EVALUATION REQUIREMENTS

I. PROPOSAL EVALUATION CRITERIA – (listed in relative order of importance)

- A. Method of Approach
- B. Qualifications & Experience
- C. Price Proposal

II. **REQUIREMENTS SPECIFIC TO EVALUATION CRITERIA:** The narrative portion and the materials presented in response to this Request for Proposal should be submitted in the same order as requested and must contain, at a minimum, the following:

A. METHOD OF APPROACH

1. What is the name and current version of the product(s) being proposed (camera, hardware, and software)?

AXON flex is a breakthrough point-of-view video system. Officers can mount AXON flex on their eyewear, ball cap, collar, helmet, epaulette, and body. No other officer-worn camera solution on the market today offers more mounting options than the AXON flex, including seamless integration with Oakley Flak Jacket ballistic eyewear. AXON flex video paired with EVIDENCE.com™ services provides agencies with a simple to use, end-to-end solution to manage their data. EVIDENCE.com simplifies digital evidence management with immediate and secure access to your agency's data via cloud technology. Our Evidence.com Dock will increase officer productivity and efficiency. The officers can dock their cameras after their shifts and it will automatically upload to the cloud and recharge the battery.

2. How long has each product component/product suite being proposed been on the market and in production status?

EVIDENCE.com has been available since 2009 when TASER released AXON Pro. TASER AXON flex and accessories have been produced and available since 2012.

3. What are your plans for future releases product and software?

When TASER releases updates on the AXON, the devices automatically upgrade to the newest firmware when they are docked into the Evidence.com Dock after an officer's shift. This requires no extra effort by the Agency.

EVIDENCE.com software upgrades are handled in a similar way. TASER will release a software update to EVIDENCE.com during a period of low traffic usage. The next time an officer logs on to EVIDENCE.com, the update will be in place.

A detailed email is sent to system administrators when new releases, updates or upgrades are made.

4. Provide a comprehensive list with descriptions and pricing of all supplemental equipment.

Please find attached, in the tabbed section of your binder, our 2014 Law Enforcement Agency Pricing – AXON Systems (FOB Destination) for our hardware, software options and accessory pricing.

5. Provide the City your proposed method of evidence storage. The Police department is open to any method evidence storage. Provide a detailed pricing list of all components required for storage (hardware costs, rates for cloud storage, etc.)

EVIDENCE.com provides to law enforcement a robust solution for organizing, classifying, managing, viewing, and archiving digital evidence, whether that digital evidence be AXON videos, still images captured by digital cameras, or even PDF documents of interrogation transcripts. TASER's hosted solution is industry-standard secure, and it implements all the proper measures to protect chain of custody.

Please find attached at the end of the proposal, our 2014 Law Enforcement Agency Pricing – AXON Systems (FOB Destination) for our hardware, software options and accessory pricing.

6. Briefly list a three year history of software releases for the product being proposed (include dates, versions, and major enhancements for each release).

Listed below is a sample set our EVIDENCE.com release notes of enhancements or new features. Full release notes and details are posted under the 'Help' section when you sign on to your Evidence.com account. When TASER releases updates on the AXON, the devices automatically upgrade to the newest firmware when they are docked into the Evidence.com Dock after an officer's shift. This requires no extra effort by the Agency.

EVIDENCE.com software upgrades are handled in a similar way. TASER will release a software update to EVIDENCE.com during a period of low traffic usage. The next time an officer logs on to EVIDENCE.com, the update will be in place.

1.17 Release Notes

Bulk Download

Users with the Download permission enabled can now download multiple pieces of evidence at one time. After clicking download with multiple files selected, the user will receive an email with a download link to a single zip file containing all of their requested evidence.

Admins are able to expire passwords for all users in the agency

This feature stemmed from the Open SSL heartbleed bug and will allow an admin to Effectively force agency-wide password resets.

Release: 1.16

Release Date: October 01, 2013

1.1 External Sharing

From this release onwards, agency administrators (or users in any role with external sharing permissions) can share evidence with users belonging to other agencies as well as external stakeholders with an email address, such as the district attorney (DA).

1.2 Redaction

Users with EVIDENCE.com Pro licenses will now have the ability to redact and edit uploaded video files. Note: The original file remains unaltered and accessible in its original form using the familiar Download link. The redacted file is available for download in the Clips section.

Release: 1.15

Release Date: January 23, 2013

1.1 Device Bulk Assignment

From this release onwards, agency administrators can assign devices to multiple users in their agency in a single step. Note: Prior to this release, agency administrators could only assign devices to one user at a time.

1.2 Ability to Disable Pre-Event Buffering

Agency administrators can now disable the Pre-Event Buffering option for their agency's AXON Flex devices from the **TASER Video Settings** page.

1.5 Restricted Category Access

If a piece of evidence contains highly sensitive material, agency administrators can implement the 'Restricted Category Access' feature in order to lock down that evidence from all users (including the evidence owner and administrators) except those belonging to one particular role.

Evidence which is assigned to 'Restricted Category' cannot be viewed by a user whose role does not have the Evidence Management 'Restricted Category Access' permission set to 'Allowed.' In addition, that role should also have the Evidence Management 'View' permission set to 'Any Evidence'. Note: Regular evidence permissions still apply. To view evidence not assigned to them, users must have the 'Any Evidence' permission enabled.

Release: 1.14

Release Date: August 2, 2012

1.1 Search Permissions

The **Search Access** permissions are displayed on the Roles and Permissions page. Agency administrators can allow or prohibit **User, Evidence, Device, and Case** Search results to display for a specific role.

2 ENHANCEMENTS

This release includes the following enhancements:

- [Enhanced Multi-file Uploader](#)
- [Updated and Merged Settings Menu](#)
- [Updated Account Settings](#)
- [Updated Configuration Settings](#)
- [Updated Security Settings](#)
- [Live Update for Bulk Actions](#)
- [Download SYNC Location](#)
- [Restructured Help Center](#)
- [Login Error Message](#)

Release: 1.13

Release Date: May 1, 2012

1 NEW FEATURES

This release includes the following new features:

Dual Factor Authentication for Critical Actions
System Alerts
AXON Flex Video Title

1.1 Dual Factor Authentication for Critical Actions

Users and administrators will be prompted to answer their security questions when they attempt any of the following actions:

- Deleting evidence
- Assigning evidence to a category with a lower retention policy
- Deleting a case
- Assigning a case to a category with a lower retention policy
- Changing a category retention policy
- Deactivating a user
- Changing a user's role
- Changing a role's permission
- Adding or deleting IP addresses or IP address ranges
- Disabling IP restrictions
- Disabling Dual Factor Authentication
- Enabling or disabling any of the Security Settings
- Creating categories

Once the users have answered the questions, the authentication will not be required for the next 60 minutes on trying any of the above actions.

Release: 1.12

Release Date: March 8, 2012

1 NEW FEATURES

This release includes the following new features:

Support for the AXON Flex system
Display of User Initiated Evidence Deletions (manual) on Administrator Dashboard
Case Player
Case Search Option
Dual Factor Authentication Setting

1.1 Support for the AXON Flex System

The videos recorded on AXON Flex™ system can now be uploaded to the device owner's EVIDENCE.com account by using Evidence SYNC™ software version 1.30.2307 and later.

7. Describe any umbrella portal entrance into the various modules.

EVIDENCE.com is the umbrella portal upon which other applications could be integrated. TASER can work with the agency to provide pricing and a plan for integrations if requested.

8. There was no requirement listed in #8.

9. Provide a list of any additional software required.

The software is included in the purchase price of the EVIDENCE.com licenses.

10. Provide software and licensing requirements to be included as part of this project.

The software is included in the purchase price of the EVIDENCE.com licenses.

11. Provide the camera storage capacity.

TASER AXON cameras have up to 12 hours recording time.

12. Provide the capacity of the camera memory.

TASER AXON cameras have a full 8GB of memory.

13. Provide the process to get the audio/video from the camera/laptop to the server.

Is the process automated?

Yes, when using EVIDENCE.com and the EVIDENCE.com Dock. TASER's recommended workflow uses an EVIDENCE.com dock. The dock allows an officer to dock the AXON camera and controllers in one place. As soon as the AXON camera is docked, videos on the camera automatically begin to download. The officer simply places the camera into the docks. Not only does the dock allow for easy download, but it also charges the devices and if need be, upgrades the firmware versions without the need for a computer.

If yes, can it be set up to be automated with DIMS?

Below is an example of a possible integration plan. Your TASER Sales rep can work with the City/agency to discuss the possibilities, potential additional costs, etc.

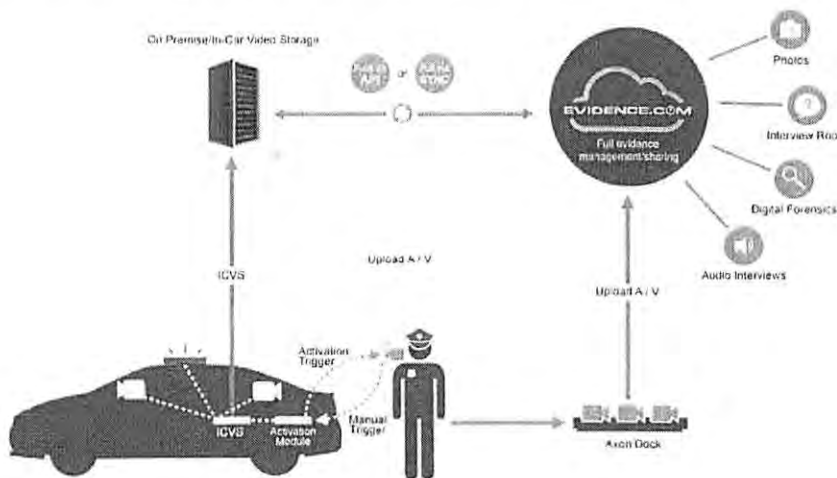

14. Provide the minimum required memory (RAM).

TASER is proposing our hosted solution EVIDENCE.com an industry-standard secure, solution so RAM is not needed.

15. Provide the minimum required processor speed.

TASER is proposing our hosted solution EVIDENCE.com an industry-standard secure, solution so processor speed is not necessary.

16. Provide the recommended network connection for audio/video upload.

The City of Tucson only needs power and an internet connection (LAN) in order to operate TASER's entire proposed system.

17. Provide the minimum network speed.

This is dependent on the available bandwidth. AXON cameras are configured with three quality settings, each having a varying bit-rate. 540 megabytes per hour at the low quality setting, 810 megabytes per hour at the medium quality setting, and 1800 megabytes per hour at the high quality setting. The medium quality setting is the most commonly used setting.

If uploading an hour of medium quality video:
2 Mbit/s - 54 Minutes
5 Mbit/s - 22 Minutes

Our Professional Service person can do an on-site review of your network to make sure it is capable of supporting AXON and EVIDENCE.com

18. In terms of the overall system design, describe the aspects of control and auditing. The system should not preclude, by way of its own design, the assessment of control aspects, compliance, electronic evidence, vulnerability, and data reliability.

EVIDENCE.com provides a number of unique, pivotal features that facilitates evidence management and coordination. To begin with, account administrators can customize the roles and authorization levels of each member of the agency's account, both to preserve chain of custody and to clarify what each user is permitted to do.

AXON provides compelling audio and video of an event as well as the 30 seconds of video prior to the event. AXON incorporates audio and video recording which can be used in a prosecution to demonstrate the events of an incident from the officer's perspective. In many cases, the presence of compelling video increases the amount of offenders who are "brought to justice." AXON increases the likelihood of successful prosecution by providing the prosecution team with evidence from the officer's Point of View (POV).

The AXON captures video as soon as an officer double-clicks the EVENT button. All video and any accompanying information are saved on the AXON until the officer docks the AXON into the EVIDENCE.com Dock. At that point, the device begins to charge, and the files begin their secure upload to EVIDENCE.com. TASER's complete on-officer video and evidence management systems safeguard against a break in the chain of custody. EVIDENCE.com automatically logs a detailed Evidence Audit Trail of anything that happens to that video or its metadata. The log can be used to determine a chain of custody that surpasses chain of custody regulations. EVIDENCE.com logs an Audit Trail for every piece of digital evidence. Below is an example of an Audit Trail on a single piece of video evidence.

19. Describe the standard training package included with the purchase of the client management software.

TASER International is offering our Premium Plus Professional Services at a 50% savings. See below for the services and training that will be provided to Tucson PD.

Services	Basic	Premium	Premium Plus
System set up and configuration	☑ (virtual)	☑ (virtual)	☑ (on-site)
EVIDENCE.com Dock installation	☑ (virtual)	☑ (virtual)	☑ (on-site)
Implementation document Package	☑	☑	☑ (custom package for larger deployments including project plan)
Axon instructor training	☑ (virtual - video)	☑ (two instructors)	☑ (up to five instructors)
Dedicated Project Manager		☑	☑
Weekly project planning call		☑	☑
Post go-live review call		☑ (virtual)	☑ (on-site)
End User go-live training and support sessions		☑ (One person - Four days)	☑ (Two people - Four days)
Best practice implementation planning session			☑ (on-site)
System Admin and troubleshooting training			☑ (Two on-site)

20. Provide all standard reports as Appendix A.

Please see Appendix A attached in the tabbed section of your binder.

21. Provide a detailed description of your training concept and materials?

TRAINING CAPABILITIES

The entire system can be implemented the day it arrives. The system is designed to be a simple, intuitive, out-of-the-box experience.

The system is designed to be an intuitive "out of the box" experience. Product manuals and Quick-Start Guides are included with the hardware, and video tutorials and FAQs are available on TASER.com. However, if the department requests on-site training and support, it can be arranged. TASER will be happy to work with the agency to construct a schedule, if necessary.

TASER International can thoroughly train users to use AXON body and EVIDENCE.com. Our Professional Services team focuses entirely on training on-site and off-site. We can train everyone from front line officers, admins who run the system, supervisors and even District Attorneys. We have a training department who has successfully trained thousands of TASER Instructors and Master Instructors. Several of our employees are retired Law Enforcement Officers who know exactly how important training is to an agency's mission. If additional training is requested by Tucson PD your account representative will work with you and your agency to determine additional needs, timing and pricing.

Users are trained on the operational and logistics of the camera systems and how to use and navigate EVIDENCE.com, how the docking station works. In-person end user training takes approximately 90 minutes

Administrators will receive additional training on how to use and easily manage Evidence.com. Administrator training generally lasts 60 minutes.

Administrators should attend all of the training sessions that are decided upon.

We also offer a Train-The Trainer session(s). We teach your trainers how to use the cameras and systems and they can then train any end users.

Centralized training can also be done easily and efficiently.

22. Identify the technical support and assistance that will include, but not be limited to, the following: devices worn by police personnel, docking/charging stations, networking equipment, WAN/LAN connectivity, system software, system upgrades and video retrieval software and procedures.

Provide days and hours that support is available?

TASER has a full customer support division. Customer service is available 24/7 via email, and live phone support Monday-Friday, 7:00AM – 5:00PM MST. For technical or Customer Service assistance please contact 800-978-2737 or customerservice@taser.com.

Updates

When TASER releases updates on the AXON flex, the devices automatically upgrade to the newest firmware when they are docked into the EVIDENCE.com Dock after an officer's shift. This requires no extra effort by the City of Tucson.

EVIDENCE.com software upgrades are handled in a similar way. TASER will release a software update to EVIDENCE.com during a period of low traffic usage. The next time an officer logs on to EVIDENCE.com, the update will be in place.

Provide methods of support contact? (email, telephone, real time online, etc)

The following describes our levels of support available in priority or tiers:

Tier 1 Technical Support (24/7):

- General how-to questions
- Frequently asked questions (FAQs)
- Product navigation
- Feature clarification
- Standard queries
- Assistance with known solutions

Tier 2 Technical Support (M-F 7:00AM – 5:00PM MST):

- Product trouble shooting
- Configuration
- Analytics

Tier 3 Technical Support:

- Critical problem or recurring problems rendering the product inoperable or requiring workarounds, bug fixes, testing and/or simulation

Provide average support call back time?

Tom Lincks, Account Manager

Tom will be your dedicated Account Manager and a supplemental point of contact within TASER headquarters. His job is to ensure a good standing health for your agency's AXON and EVIDENCE.com program by utilizing consistent communication, virtual

support, and providing the necessary resources needed to make sure you are set up for success. He can be reached at 602-770-0689.

Provide average problem resolution time?

Immediately, if the problem is reported during Regular Business Hours. There are varying degrees of problems and resolution times. Depending on the problem, response times can vary from immediate response to up to 72 hours or possibly longer. Your dedicated account manager, Tom Links, will work with the City and/or PD to get the fastest possible response time.

23. The City desires an aggressive implementation schedule. Please provide your proposed implementation schedule (starting from date of contract award), state the assumptions that are implicit in your implementation timetable (City resources, your resources, third parties, etc.), and list the effect(s) of those assumptions not being met.

Please see TASER's comprehensive Project Plan attached to the end of this proposal for full details and implementation schedule.

24. The City will perform overall project management. Describe what provisions you will make to provide a project manager for your staff who will support overall project objectives and work effectively with the City project manager and staff.

TASER Professional Service Offerings

What makes a great product better? How about a company that offers world class service standing behind it. TASER International is a company well known for its world class customer service -and it just got better! TASER International now offers Professional Services to facilitate planning and implementation of TASER solutions. With the help of TASER Professional Services you can anticipate efficient and successful deployment of your solution.

TASER Professional Services consists of a group of highly skilled individuals with in-depth knowledge of all TASER products. Premium Professional Services packages include a dedicated Project Manager who creates a custom project plan to fit your agency needs. You also receive onsite system configuration and setup along with onsite go-live training and support. There are other benefits with TASER Professional Services, such as subject matter experts who consult on best practices for setup, configuration, policy and overall program performance. Agency program success is THREE TIMES greater where Professional Services has rendered onsite support, than where we have not!

Additional packages and services are available, including CAD/RMS Integrations and Network or Application Security Assessments, custom-designed to analyze your agency's information security posture.

25. Please attach a high-level project schedule, with milestones from each implementation phase.

Please see our Project Plan attached in the tabbed section of your binder.

26. Describe your approach to project communication, the strategy, the calendar, and responsible parties.

Our Professional Services team focuses entirely on training on-site and off-site and will work with the City of Tucson to plan and implement the training. We train end users, and we have a training department who have successfully trained thousands of TASER Instructors and Master Instructors. Several of our employees are retired Law Enforcement Officers who know exactly how important training is to an agency's mission.

The Project Plan provides you with the estimated timeline needed to implement your request and program. Once a PO is received, your account and project managers will work with you to determine a specific plan based on the needs of the City of Tucson.

Listed below are our implementation best practices and a sample category and retention guide that will help to insure that your program is well thought out and runs smoothly from the start.

1. Identify Your Key Stakeholders

Although it may be argued that just about everyone in your agency and community are potential Stakeholders, let's focus on identifying typical key functions that should have direct participation in the planning of your program:

Internally, these positions may be dependent on agency size, workflows and areas of responsibility. Field personnel who will wear and use AXON are among the first and most critical. Successful programs pre-identify users who will champion the technology and assist with orienting others to its benefits. Typically, those assigned to training bureaus or as Field Training Officers make good candidates.

Responsibility for dissemination of digital evidence to State or County Prosecutors and City Attorneys, if not with individual Officers, may rest with Evidence Technicians, Property Custodians or Supervisors. If this is the case, you will want to include whichever segments of that group will be expected to play a role.

Responsibility for policy decision ultimately falls to the agency head, but typically includes members of the command staff and other agency leadership. All involved should be included.

Externally, consider including members of your Prosecutor's/City-County Attorneys or other legal representation entity. Some agencies have also included their local Defense community in some part of the planning process.

Whether internal or external, Information Technology personnel should be included early in your planning process. They will play a key role in helping you determine if any pre-deployment IT infrastructure work will be required and will be a better resource for your program if included in its development.

2. Make Some Decisions and Draft Your Policy

Some decisions need to be made pre-deployment so that your Users will have at least a draft policy to abide and be guided-by. Some of the security and password options may already be covered in your City, County, State law, Agency IT or Digital Evidence Policy, but some are unique to AXON. Roles and Permissions in EVIDENCE.com may follow the default settings but most likely should be customized to your agency's needs.

A key workflow consideration involves the process for adding metadata (case number, category, title) to each event an officer or deputy captures. Clearly, the best workflow is to incorporate a smartphone or smart device that can be carried by the officer and leverages today's mobile technology. If smartphones aren't within budgetary reach, smart devices, such as the Samsung Player or Apple iPod Touch provide mobile functionality without the need for monthly subscription. The next-best workflow can be accomplished using in-car mobile data computers and EVIDENCE SYNC to view videos and add metadata. A downside to this process is the need to power-down the AXON device and make a physical connection to the computer each time viewing or adding metadata. The least efficient process for adding metadata is to have officers do so using station or mobile data computers following upload to EVIDENCE.com, typically on their next work-shift.

Key Role & Permissions Questions

- A. Will User-Officers be allowed to view only their own evidence, or that of others?
- B. Will User-Officers be allowed to download their evidence?
- C. Will User-Officers be allowed to share their evidence?
- D. Will FLEX Head-Only wear be mandated? (if so, consider also allowing collar or other mounting options for breaks or relief periods)

Each of these questions will directly relate to Role and Permission settings in your EVIDENCE.Com account.

Categories and Retention

One of the most crucial roles of EVIDENCE.com is the proper management of all types of digital evidence. For proper management, create a set of agency-specific Categories that is large enough to properly segregate evidence by type for retention-setting and search functionality, but not so large that it becomes an impediment to efficient field use by the Users. Agencies are encouraged to consult State Retention Schedules, City/County or State Attorneys or other legal counsel for guidance on proper retention setting.

Uncategorized Evidence

Under the default settings, uncategorized evidence is retained until manually deleted. If you plan to mandate and vigorously enforce the addition of metadata, this setting should work well. The default setting will prevent inadvertent deletion of important evidence, but could also create unnecessarily-retained events if metadata compliance is not very high. If however, you are concerned about the amount of time required to 'tag' every event captured, or you want to keep unnecessary retention to an absolute minimum, you can set a deletion period for evidence which has not been categorized.

Some agencies with large traffic or motor units have chosen this option so that brief warning contacts do not require any further action by officers. Give this setting careful staff consideration before making your choice.

Restricted Category

Agencies can create a unique role for those who will have sole access to highly sensitive event recordings. Typically this role will be reserved for the agency head, executive or command staff or professional standards/internal affairs staff. If you choose to create a restricted category, consider the workflow instruction for who will be responsible and when your field supervisory staff will be required to categorize evidence as "Restricted".

3. **Install, Configure and Test Your System**

Upload to EVIDENCE.com with the Evidence Transfer Manager (ETM -Docks) is designed to be seamless and very efficient. Part of the planning and pre-sale process will be to identify your agency's bandwidth requirements and ensure your internet connectivity will support peak needs. TASER Pre-Sales and Professional Services staff can help you estimate and address this.

4. **Train the First Wave**

An initial, limited number of Key Users, Armorer(s) and System Administrator(s) should be trained. The size of this contingent depends on agency size or size of the planned full deployment. These officers will serve a number of roles, including final confirmation of system functionality and performance. They will likely provide useful feedback on any localized issues that had not been previously identified. They will provide a demonstration and information platform for their co-worker/future User Officers. They typically become a resource when newer Users are activated and require training or assistance.

5. **Start Small, Test, Assess, Correct, and then Go Big**

Deploy the Key Users. Make sure the way you've configured your system integrates smoothly into your workflow. Assess readiness based on evaluation and feedback and make any necessary adjustments. Once you've taken these steps you're ready to schedule the rest of your User training and full deployment "go-live".

6. **Don't Forget the Media**

Your choice to deploy On-Officer video is a matter of community interest. Local Media typically take interest in new programs and can give yours a boost with positive, well-informed reporting. Don't leave the details for members of the media to go out and find. They may find those details from an agency that has planned their program less carefully, or with a less-capable product line.

7. **Get Creative. Get Efficient**

Agencies have used AXON and EVIDENCE.com to improve on efficiencies and minimize Officers' time spent on report writing. Aside from minimizing time and resources spent on frivolous or malicious citizen complaints, on-officer video can be used to document routine events, low priority or 'cold' crimes or other administrative or 'service-only'

activities. Officers may be trained to narrate minor investigations while they are recording with AXON. They may be allowed to document victim, witness or suspect statements during certain types of investigations.

AXON recordings can be used to enhance new-officer or in-service training. Many training academies and Field Training Programs have improved on the quality of training provided and reduced the time required waiting for opportunities to encounter certain high-risk/low-frequency events.

8. **Maximize the Power of EVIDENCE.Com**

EVIDENCE.com was designed from the ground up as a total digital evidence management solution. Digital photos, audio, in-car, interview room, security and surveillance video can all be ingested for efficient and proper digital evidence management and storage. Less expensive archival storage is also available for exceptionally large or long-term digital evidence types.

B. QUALIFICATIONS AND EXPERIENCE

1. Please provide a list of all government (or comparable) installations, within the last three years, in metro areas over 250,000 in population, with contact names, positions, e-mail addresses, and telephone numbers.

TASER International has literally hundreds of contracts/agreements with large agencies. Our current customer projects require a level of confidentiality therefore, we can't provide specific information, however several of the agencies who have agreed to be contacted are listed on the "Confidential" reference sheet. It is in the front of your binder in an envelope marked "Confidential References". The "Original" binder also has a separate CD that is marked as well.

2. Name, corporate address, and number of years in business under current company organization.

TASER Corporate Information

<p>Credentials TASER provides body-worn cameras to Law Enforcement, and has been providing these services for 8 years. TASER uses customer input to continuously improve our products. Our products have a laser-like focus on the law enforcement market.</p>			
<p>Background and Organizational History TASER International was founded in September 1993 and has remained committed to providing solutions which Protect Life and Protect Truth. In May 2001, the company became publicly traded on the NASDAQ stock exchange (TASR). Since that time, TASER has launched several new products, such as X26 CEW (2003), TASER CAM (2006), X3 CEW (2009), AXON PRO (2009), EVIDENCE.com (2009), X2 CEW (2011), AXON flex (2012), and AXON body and X26P CEW (2013).</p>			
<p>Years in Business: 21 years</p>			
<p>Performing like Services: 8 years</p>			
<p>Location of HQ and Other Offices:</p> <table border="0" style="width: 100%;"> <tr> <td style="text-align: center; width: 50%;"> <p>TASER HQ 17800 N. 85th Street Scottsdale, AZ, 85255</p> </td> <td style="text-align: center; width: 50%;"> <p>TASER Washington 506 2nd Ave Floor 14 Seattle, WA 98104</p> </td> </tr> </table>		<p>TASER HQ 17800 N. 85th Street Scottsdale, AZ, 85255</p>	<p>TASER Washington 506 2nd Ave Floor 14 Seattle, WA 98104</p>
<p>TASER HQ 17800 N. 85th Street Scottsdale, AZ, 85255</p>	<p>TASER Washington 506 2nd Ave Floor 14 Seattle, WA 98104</p>		
<p>Number of Employees: 400+</p>			
<p>Client Base: TASER's Client Base is primarily the Law Enforcement market, and has been since TASER's inception in 1993.</p>			
<p>Type of Business: Corporation</p>			

3. Type and number of employees committed to the product and support being proposed.

In addition to your dedicated sales representative, account manager, customer service team and professional services team, TASER's R & D Departments is in Scottsdale, AZ. We also have an office in Seattle, WA where many of our developers are located. Both teams work in tandem and spend approximately 50% of its manpower on our camera and EVIDENCE.com platforms.

4. Please provide, as Appendix B, a description of business and development plans for all product and support services proposed in connection with this submission.

As a publicly traded company we can't provide guidance. We can share our investor relations Q2 presentation that is in the tabbed section of your binder. Q3 will be released in mid-November. Please contact us for a link to the most recent release.

5. Briefly describe your own project management methodology.

TASER's AXON flex and EVIDENCE.com solution offers many advanced capabilities, however the most successful programs are those that are well-planned, and include as many stakeholders as possible before fully deploying. Your program can be as transformative, ambitious, and creative as you wish. We have found that deliberately phased program components tend to have the most success, as they allow for agency or regionally-specific decision points to emerge and be addressed as the program rolls out.

Our Project Plan (included in the tabbed section of your binder) can be modified to meet the needs of the City of Tucson.

TASER International will be the prime contractor with no subcontractors or partners. TASER uses several testing platforms to ensure we hire qualified and proficient technical personnel, including a Predictive Index (PI) test, salesmanship test, as well as a rigorous interview process and assignments prior to being offered a position. TASER's interview process is several days long, and usually requires more than two trips to TASER HQ for day-long interviews, including one-on-one interviews and group interviews. Any technical personnel are interviewed by other technical personnel and are required to showcase their skills in a pre-employment assignment. We also check references and require a portfolio for technical personnel.

Laurie Bain: VEST Regional Sales Manager

Laurie is your regional sales manager. Laurie and the team will work with Tucson PD to provide professional recommendations and resources throughout all phases of the sale from initial evaluation to implementation. Laurie has been employed by TASER since 2013, working with many Law Enforcement customers on multiple products and services since.

J.R. Miller: Director of Customer Service and Account Management

J.R. oversees the customer service department and Account managers at TASER, including live phone support and Account Management. Although J.R has only been with TASER for a few months, he has a 16-year track record of success and achievement in the field of IT sales and services.

Joe Fiumara: Director of Professional Services

Joe is a retired police captain who has overseen successful deployments of AXON on-officer video and Evidence.Com in his previous role, and since joining TASER International, where he has overseen implementations at over 30 agencies ranging from 10 over 1000 sworn. Joe was an early advocate and adopter of on-officer video and a frequent contributor to model policy and best practice developments. He holds a B.S. in Criminal Justice from Kennedy Western University and is a graduate of FBI National Academy 230th session.

Tom Lincks: Account Manager

Tom will be your dedicated Account Manager and a supplemental point of contact within TASER headquarters. His job is to ensure a good standing health for your agency's AXON and EVIDENCE.com program by utilizing consistent communication, virtual support, and providing the necessary resources needed to make sure you are set up for success. Tom Graduated from Arizona State University with a Degree in Business with a concentration in Sustainability. Tom has been with TASER for over 2 years, starting out in our Training department and then moving on to be the Account Manager for the Western region. He is based out of TASER HQ in Scottsdale, AZ.

Uri Halioua: Pre-sales System Engineer

Uri is a Subject Matter Expert (SME) on on-body video, digital evidence capture devices, and TASER's AXON flex and body On-Officer video capture devices as well as EVIDENCE.com and other forms of digital evidence management. He conducts customer site assessments, including network, electrical, and physical assessments. He also provides pre-sales engineering providing support to both the domestic and international sales teams.

Billy Doss: Field Services Manager

Billy has a diverse product and services background with TASER International. He is responsible for coordinating onsite systems configuration and deployment, and has overseen numerous successful domestic and international program launches. Billy has been with TASER since 2007 and is based out TASER HQ in Scottsdale AZ.

Doug Dirren: Professional Services Manager

Doug began his career as a police officer in 1981 with the Scottsdale, AZ Police Department. He also taught law enforcement and military personnel in the US as a TASER Senior Master Instructor until he concluded his 30 year career in law enforcement. In 2011 Doug began working at TASER where he taught Instructor, Technician and Evidence Collection courses domestically and internationally. In 2012 he became a Regional Sales Rep where he managed all sales of TASER weapons to law enforcement and professional security in eight states.

Recently, Doug transferred to the position of Professional Services Manager where he works with agencies to set up AXON Camera and Evidence.com programs, analyzes digital evidence workflows and provides support of their current weapon programs. With a Bachelor of Science degree in Public Administration, Doug resides in Scottsdale.

All of these individuals, and others, work together to be an unbeatable team when it comes to the implementation of TASER AXON products and EVIDENCE.com including the day to day service and support expected by the Tucson PD.

Our Professional Services team focuses entirely on training on-site and off-site and will work with the Tucson PD to plan and implement the training. We train end users, and we have a training department who have successfully trained thousands of TASER Instructors and Master Instructors. Several of our employees are retired Law Enforcement Officers who know exactly how important training is to an agency's mission.

C. PRICE PROPOSAL

1. Provide price proposal as requested on the Price Page attached herein.

2. As stated in the Instructions to Offerors, 7. Discounts, the price(s) herein can be discounted by 0%, if payment is made within Net 30 days. These payment terms shall apply to all purchases and to all payment methods.

3. Cooperative Purchasing Program: Will your firm provide the City of Tucson, as the lead agency on this regional contract, a rebate in the form of a percentage of sales based upon the other agencies sales?

_____ Yes No If yes, state proposed percentage: _____%

4. Will payment be accepted via commercial credit card? Yes _____ No
 - a. If yes, can commercial payment(s) be made online? _____ Yes No
 - b. Will a third party be processing the commercial credit card payment(s)? ___ Yes No
 - c. If yes, indicate the flat fee per transaction \$ N/A (as allowable, per Section 5.2.E of Visa Operating Regulations)
 - d. If "no" to above, will consideration be given to accept the card? N/A Yes _____ No

5. Does your firm have a City of Tucson Business License? Yes No
If yes, please provide a copy of your City of Tucson Business license.

Our legal department applied for a City of Tucson Business License but were told it was not needed. Reason listed below:

According to the information provided, TASER International, Inc. does not need a Tucson business license due to Scottsdale taxing jurisdiction. If TASER International, Inc. opens any physical locations in Tucson or closes the Scottsdale location, a new determination would be required.

PRICE PAGE

TASER Quote # Q-18016-1 also attached in the tabbed section of your binder. If the Tucson PD purchases Ultimate EVIDENCE.com licenses for their officers, this includes 3% of the purchased amount in spare equipment. TASER's quote reflects this policy. We will provide a 3% surplus of AXON devices marked "SPARE" for free. This quote + free spares means that the Tucson PD will always have a fully operational device ready as a backup.

TAP Upgrade Program

Purchasing Ultimate EVIDENCE.com licenses is the best value for the Tucson PD. Ultimate EVIDENCE.com Licenses: Full functionality of EVIDENCE.com, including sharing, video clips and markers, video redaction, full AXON Camera Warranty, Automatic AXON Camera Upgrades at year 3, and 20 GB of storage per year included. Ultimate licenses come with a "no questions asked" complete warranty, on-site spare devices, and a replacement camera at year 3.

TASER does offer EVIDENCE.com licenses with less functionality if the department prefers. This package is TASER's best value, and many other major cities choose this option because it offers security and full warranty, spare gear, and automatic upgrades. However, if the Tucson PD does not need all of these benefits, TASER offers less expensive alternatives.

Year One

<i>Item No.</i>	<i>Description</i>	<i>Estimated Annual Quantity</i>	<i>Unit Price</i>	<i>Extended Price</i>
	Body Worn Camera, as per specification AXON flex Kit #73030 Manufacturer and Model #	40 Each	\$ 499.95	\$19,998.00
2	Software, as per specification Ultimate Evidence.com Annual Payment #85078 Manufacturer and Model #	40 Each	\$588.00	\$23,520.00
3	Initial Product Training	40	\$_____per person	\$ See Below
4	Train the Trainer program	1	\$_____per class	\$ See Below

5	TASER is offering Premium Service Plus Training Services at a 50% Discount – See Page 9 for services breakdown Premium Plus Service # 85055			\$7,500.00
6	Collar/Versatile/Cap Mount, Flex TASER # 73009	40	\$0.00	\$0.00
7	Controller, Holster, Belt Clips, Flex TASER # 73036	40	\$0.00	\$0.00
8	3 Year TASER Assurance Plan AXON Flex TASER # 85074	40	\$0.00	\$0.00
9	EVIDENCE.com, Dock, Six Camera Bays + Hub TASER # 70026	7	\$1,495.00	\$10,465.00
10	3 Year TASER Assurance Plan ETM Hub TASER #85091	7	\$0.00	\$0.00
11	3 Year TASER Assurance Plan ETM 6 Bay TASER #85093	7	\$0.00	\$0.00
12	TASER Assurance Plan ETM Annual Payment TASER #85079	40	\$36.00	\$1,440.00
13	Evidence.com Storage TASER #85035	800	\$0.00	\$0.00
14	Standard Evidence.com License: Year 1 Payment TASER #88101	10	\$300.00	\$3,000.00
15	Evidence.com Storage TASER #85035	100	\$0.00	\$0.00
16	Evidence.com Storage TASER #85035	3,200	\$1.50	\$4,800.00
17	Kit, AXON Flex TASER #73030	1	\$0.00	\$0.00
18	Collar/Versatile/Cap Mount, Flex TASER #73009	1	\$0.00	\$0.00
19	Controller, Holster, Belt Clips, Flex TASER #73036	1	\$0.00	\$0.00
20	3 Year TASER Assurance Plan AXON Flex TASER #85074	1	\$0.00	\$0.00
	Year One – Total Hardware, accessories, software licenses and training			\$70,723.00

Year Two

<i>Item No.</i>	<i>Description</i>	<i>Estimated Annual Quantity</i>	<i>Unit Price</i>	<i>Extended Price</i>
1	Ultimate Evidence.com Annual Payment #85078	40	\$588.00	\$23,520.00
2	Evidence.com Storage TASER #85035	800	\$0.00	\$0.00
3	Standard Evidence.com License: Year 2 Payment TASER #88201	10	\$300.00	\$3,000.00
4	Evidence.com Storage TASER #85035	100	\$0.00	\$0.00
5	Evidence.com Storage TASER # 85035	3,200	\$1.50	\$4,800.00
6	TASER Assurance Plan ETM Annual Payment TASER # 85079	40	\$36.00	\$1,440.00
	Year Two – Total			\$32,760.00

Year Three

<i>Item No.</i>	<i>Description</i>	<i>Estimated Annual Quantity</i>	<i>Unit Price</i>	<i>Extended Price</i>
1	Ultimate Evidence.com Annual Payment #85078	40	\$588.00	\$23,520.00
2	Evidence.com Storage TASER #85035	800	\$0.00	\$0.00
3	Standard Evidence.com License: Year 3 Payment TASER #88301	10	\$300.00	\$3,000.00
4	Evidence.com Storage TASER #85035	100	\$0.00	\$0.00
5	Evidence.com Storage TASER # 85035	3,200	\$1.50	\$4,800.00
6	TASER Assurance Plan ETM Annual Payment TASER # 85079	40	\$36.00	\$1,440.00
	Year Three – Total			\$32,760.00

Totals for Three Years

<i>Item No.</i>	<i>Description</i>	<i>Estimated Annual Quantity</i>	<i>Unit Price</i>	<i>Extended Price</i>
1	Year One			\$70,723.00
2	Year Two			\$32,760.00
3	Year Three			\$32,760.00
4	Total Estimated Sales Tax			\$11,193.70
5	Estimated 3 Year Grand Total			\$147,436.70

AXON FLEX AND EVIDENCE.COM INTRODUCTIONS AND SUMMARY

OVERALL DESCRIPTION OF THE PROJECT

Tucson PD is looking for information for Police Body Worn Cameras, with integrated video storage and retrieval software systems. The goal of your Request for Proposal (RFP) is to research the latest technology available in the market for police body worn cameras, and the accompanying storage and retrieval systems. The cameras will be utilized as a tool to enhance your ability to accurately capture video and audio evidence as events occur and to assist in the prosecution of cases. TASER's proposal outlines exactly that: simplicity in a turn-key system, complete with cameras, software, completely scalable storage, with full maintenance and support, upgrades, and program management. For added simplicity, the department will only need to work with one vendor for the fulfillment of the entire system. TASER performs every portion of the system implementation and support.

Tucson PD will find the "Full System" with TASER, including all necessary elements to implement a successful BWC program. Tucson PDs goals also align with the results TASER has seen at other large agencies who have deployed AXON video and EVIDENCE.com. Most agencies have some of the following goals when implementing a Body Worn Camera program:

- Enhance officer safety
- Enhancement of officer reporting
- Evidence collection
- Court testimony
- Provide accurate documentation of events, actions, conditions, and statements made during arrests and critical incidents
- Officer evaluation and training
- TASER's system complies with CJIS

Enhance Officer Safety

Cambridge University and Rialto PD released a comprehensive year-long study on AXON/EVIDENCE.com. Over the course of one year, officer complaints fell by 87.5% for officers wearing an AXON.

Rialto PD also focused on their Officer use-of-force data. During the experiment, **individuals wearing an AXON reduced use-of-force by 59%**. This data indicates that the presence of the camera not only encouraged compliance from the public, but it also reduced instances of use-of-force by officers. These major shifts in complaints and use-of-force were attributed solely to the presence of an AXON flex.

Our current customers who are trialing AXON are also seeing positive results in line to enhance officer safety. Sgt. Dan Gomez of LAPD said in a CBS article from 1/15/2014,

"When you interact on camera, you tend to act differently, and that's true for a police officer, and true for the community that you're dealing with. So if it has the potential of de-escalating a situation — because you believe the camera is on and the camera is recording — and you change for the better, it's a win for both."

Enhancement of officer reporting

Investigative Services can benefit from body-worn cameras. A routine witness testimony could be captured using an AXON, instead of being notated on a 3"x4" card. Paperwork for these interviews could be reduced to "See AXON Video." This exact procedure is currently being used by Lake Havasu PD in Arizona. Instead of writing a detailed description of an event, the officer references the AXON video. "See Video" takes much less time to report. Lake Havasu PD uses this method for paperwork, and saw a 7.7% decrease in overtime pay after implementing TASER's video system.¹

Evidence Collection

Tucson PD can capture nearly 2x as much evidence with AXON body's extra-wide 130° field of view. AXON's field of view will capture nearly 2x as much evidence video as the competitor. AXON body was designed to capture a wide field of view to capture accurate evidence, even when the device is mounted on an officer's beltline. The competitor's camera captures much less, which could miss important footage. With AXON body, the Tucson PD could capture more than with the leading competitor, for a lower cost per unit.

The AXON flex system offers a slightly lower field of view at 70° but has a larger variety of mounting options.

Both systems integrate seamlessly with our accompanying storage and retrieval systems EVIDENCE.com.

Court Testimony

Many of our customers use video in the court room instead of sending an officer to testify. This saves the Officer's valuable time. Instead of spending hours in a court room, he or she can stay on their patrol while the video tells the entire story in the court room. While being interviewed for their policies on Body Worn Cameras, a spokesman for the Prince George's County state's attorney's office said, "Anytime we can have use of technology to prove our case, we're going to be supportive of it. This will be another good tool," Their Attorney's Office handles cases from Laurel and Hyattsville — another department that has begun using cameras. Both Hyattsville and Laurel have implemented AXON and EVIDENCE.com.

Provide accurate documentation of events, actions, conditions, and statements made during arrests and critical incidents

¹ Data gathered from Lake Havasu PD during a 2012 deployment of the AXON cameras. The full case study can be found at the end of this proposal.

Many of our customers use AXON cameras to take statements, record actions, and show a “full picture” of a critical event. Our camera also has a critical “30 second pre-event buffer,” which also captures the 30 seconds prior to an officer hitting the record button. These 30 seconds often helps to set up the context leading up to a critical event. The Police Chief of LAPD, who is currently testing TASER’s AXON and EVIDENCE.com, has said about AXON cameras,

“The addition of on-body cameras will be a helpful investigative and accountability tool, as well as a less expensive option than in-car video.”

Officer evaluation and training

Santa Fe College PD and Laurel PD in Maryland use AXON cameras for training during tactical use, courses, classes, routine stop courses, defensive driving courses, Emergency Vehicle Ops, and use-of-force training. We also see our cameras used often in SWAT trainings. We also have a full training department on-site which can assist our team in recommending the industry best way to use BWC during training exercises. If Tucson PD would like to see any of our current use-cases and training videos, please contact Fabian Marrero at fmarrero@taser.com.

Tucson PD’s success with Body Worn Cameras depends on a vendor who can execute on the following three things:

1. A quality camera that brings added value to the department
2. Professional Services, Maintenance, and Support
3. Turn Key video management system

TASER International, Inc. has proven experience executing all three of these items for customers in the past. To keep things simple for Tucson PD, all of these items are performed directly by TASER. Tucson PD does not have to worry about vetting subcontractors, because we offer the entire solution. This keeps things simple – you’ll have just one vendor to call when you need assistance.

- Don’t build anything – scale your storage up and down every year without adding servers.
- Don’t install anything on user’s computers– your users will have instant access to EVIDENCE.com via a web browser.
- Full roll-out support – TASER has over 18,000 cameras in the field and has performed many successful implementations.
- Full training and implementation support from TASER – Our Professional Services department travel across the USA doing implementation support for Law Enforcement customers.
- TASER Program Management – Our Professional Services team is led by a Retired Police Captain who went through a BWC implementation at his PD.
- Full Hardware and Software warranty as long as the department is on Ultimate license

ACCOMPLISHMENTS IN THE BWC INDUSTRY

Today, TASER has sold over 18,000 BWC units into the Law Enforcement Market. We have had more Major City Departments deploy our cameras than our competitors combined. TASER has already sold more than 10,000 BWC units in 2014. Below is a short list of our largest customers:

Department	State	# of Cameras	EVIDENCE.com Account
Fort Worth Police Department	TX	615	Yes
Albuquerque Police Department	NM	600	Yes
New Orleans Police Department	LA	450	Yes
Greensboro Police Department	NC	297	Yes
Salt Lake City Police Department	UT	260	Yes
Spokane Police Department	WA	220	Yes
Bay Area Rapid Transit Police Department	CA	220	Yes
Chesapeake Police Department	VA	210	Yes
Las Vegas Metropolitan Police Department	NV	200	Yes
Modesto Police Department	CA	168	Yes
Mesa, Police Department	AZ	150	Yes
Newport News Police Department	VA	110	Yes
Rialto, Police Department	CA	100	Yes
Dallas-Fort Worth International Airport PD	TX	100	Yes
Coweta County Sheriff's Department	GA	100	Yes
Surprise Police Department	AZ	86	Yes
Sanford Police Department	FL	80	Yes
Topeka Police Department	KS	75	Yes
Fort Collins Police Department	CO	61	Yes
Oglala Sioux Tribe DPS	SD	61	Yes
Lake Havasu, AZ Police Department	AZ	60	Yes
Merced, Police Department	CA	50	Yes
Winston-Salem Police Department	NC	45	Yes
Wichita Police Department	KS	40	Yes
Sanford Police Department	FL	80	Yes
Topeka Police Department	KS	75	Yes
Fort Collins Police Department	CO	61	Yes
Oglala Sioux Tribe DPS	SD	61	Yes
Lake Havasu, AZ Police Department	AZ	60	Yes
Merced, Police Department	CA	50	Yes
Winston-Salem Police Department	NC	45	Yes
Wichita Police Department	KS	40	Yes

An independent survey by online magazine PoliceOne.com revealed that police officers perceived TASER to be the market leader in on-officer video by a wide margin. After releasing the flex camera system in February of 2013, the flex has taken off with success after success because of a simple fact—we know what law enforcement wants in on-officer video. Now, AXON body is taking off as well. See what officers from early-adopting agencies had to say:

Fort Worth (TX) Police Chief Jeff Halsted: "On-officer video systems like the AXON Flex give us an opportunity to showcase and support the jobs our officers are doing in the field. Having a complete video record of these incidents will provide a higher level of protection for both our officers and the public."



Sergeant Brandon Davis

Greenwood (AR) Police Department Sergeant Brandon Davis: "I loved the multiple mounting options of AXON Flex. The integration with Oakley makes it cool & comfortable. This is a system officers will want to wear."

NY Times Article on Rialto (CA) Police Chief William Farrar's Study: "Even with only half of the 54 uniformed patrol officers wearing cameras at any given time, the department over all had an 88 percent decline in the number of complaints filed against officers, compared with the 12 months before the study, to 3 from 24"

Mesa (AZ) Police Chief Frank Milstead: "As evidentiary technologies evolve, so do the expectations of the judicial system and the community. It is imperative law enforcement keep pace with these expectations. The AXON platform provides our officers the safest and least intrusive system to obtain, provide and store such evidence."

New Orleans Police Superintendent Ronal Serpas: "I believe that the use of TASER's AXON Flex body worn cameras and the use of Cloud technology with EVIDENCE.com is a game changer for police departments here and around the world. Deployment of this equipment provides police and the community an opportunity to reconstruct events in a way that advances safety, accountability, transparency, and professional policing."

PROPOSER'S CAPABILITIES

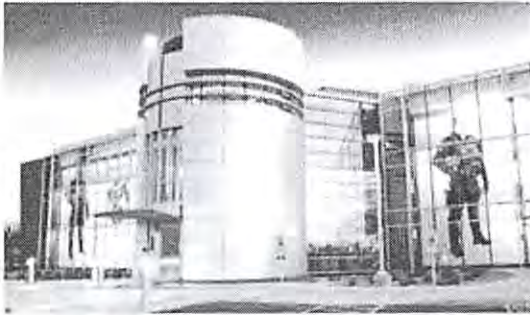

*TASER International Headquarters:
Scottsdale, AZ*

Tucson PD wants a proven vendor who can handle the size and scope of Tucson PD's BWC program, and implement it successfully. To date, TASER has deployed over 60,000 TASERCAMs and over 18,000 BWC devices exclusively to Law Enforcement departments. And ever since TASER was founded 21 years ago, we have focused on the Law Enforcement market. That means that Law Enforcement agencies and leaders have helped us develop our products and services. Everything we make and support is a direct result of Law Enforcement needs.

TASER's Mission: Protect Life. Protect Truth.

TASER's industry-leading Conducted Electronic Weapons (CEWs) are used worldwide by law enforcement, military, correctional, professional security, and personal protection markets. TASER CEWs use proprietary technology to incapacitate dangerous, combative, or high-risk subjects who pose a risk to law enforcement/correctional officers, innocent citizens, or themselves; and CEWs are generally recognized as a safer alternative to other uses of force. TASER technology protects life, and the use of TASER devices dramatically reduces injury rates for law enforcement officers and suspects. Today, over 17,000 law enforcement agencies use TASER CEW's, and they are used in more than 40 countries worldwide.

TASER International was founded in September 1993 and has remained committed to providing solutions which Protect Life and Protect Truth. In May 2001, the company became publicly traded on the NASDAQ stock exchange (TASR). Since that time, TASER has launched several new products, such as X26 CEW (2003), X3 CEW (2009), AXON PRO (2009), EVIDENCE.COM (2009), X2 CEW (2011), AXON flex (2012), AXON body and X26P CEW (2013).

From its industry-leading CEWs, to its AXON/EVIDENCE.com video recorder and storage system, TASER is committed to reducing violent confrontation, providing accountability, and preventing danger. TASER is the industry leader in on-officer video devices, with over 60,000 of its video recording devices in the field.

The team at TASER is committed to protecting life by providing innovative, high quality products and services that exceed customer expectations every time. The ISO 9001:2008 certification of quality management system demonstrates the company's commitment to quality for its customers, employees, and suppliers. This supports a continual improvement philosophy, which is the responsibility of every employee.

The TASER Experience

TASER believes that its success in the law enforcement industry has been thanks to a keen understanding of the unique needs of policing. We understand that our technology must not only serve to protect officers in the field, but it also must be easy to use, it should make the lives of those officers easier, and it ought to address the day-to-day realities of life on patrol.

This commitment to our customers is more than evident in the design of the AXON flex. TASER's partnership with Oakley's Eyewear ensures that our camera is something officers *want* to be seen wearing, and officers never need to worry about whether the camera is properly fastened—they often forget it is there.

When we developed AXON body, we listened to our customers' need for something simple to operate. We developed the AXON body because our customers loved our 30 second buffering, the retina low-light capability, the quality of the video evidence we produce, and for the EVIDENCE.com workflows we offer. Some customers wanted everything we offer with flex, just in a simpler camera.

We do our utmost to produce the highest quality cameras. We inspect all incoming parts, oversee inventory replacement, conduct rigorous validation procedures, collect feedback from trials, and allow for almost no variance in the manufacturing process. The result is a consistently great product that can ably serve law enforcement.

Finally, TASER also takes every step to ensure that you have a hassle-free out-of-the-box experience. The steps for activating a body cam or flex unit are almost as quick and easy as activating an iPad. We follow through as well. TASER offers around-the-clock customer support and will help your agency every step of the way as you adopt this new paradigm in police technology.

Your TASER Account Manager/ Point of Contact

Video Systems Contact
Laurie Bain
VEST Regional Sales Manager
TASER International, Inc.
Lbain@taser.com
480-349-9906

EXECUTIVE SUMMARY – TASER

Tucson PD will find the simple, turn-key solution to implementing body worn cameras with TASER. TASER offers AXON body and AXON flex our simplest cameras to operate, and EVIDENCE.com, our turn-key cloud-based storage and management system.



*AXON flex system, shown with the Oakley Flack Jacket Mount option.
This is one of over 10 mounting options TASER offers with the AXON flex.*

Using proven technology best equips your officers. Because on-officer video is a new venture for Tucson PD, TASER can be a trusted partner in rolling out a customized video and evidence management solution. TASER strongly believes that body-worn video would surpass the PD's expectations to better capture events as they occur; assist in the prosecution of cases; and protect the department, Agency, City, and officer from frivolous accusations.

PROTECTING & ADVANCING EVERY OFFICER

Tucson PD has diverse Units and Teams within the agency, and many officers may spend little to no time in a police cruiser during their tactical assignments. From our research, officers experience most of their tactical events away from their vehicle.

AXON FLEX FEATURES, BENEFITS, AND ADDED VALUE

Features	Benefits	Added Value
Video Resolution 640 x 480	Good resolution without the massive file sizes of HD video. Officers will use roughly 100GB of storage per year with 640 x 480. With HD, they could use nearly 1000GB of storage per year. That is roughly 10x the amount of storage.	X
30 Second Pre-Event Buffer	This technology captures the 30 seconds of video prior to an officer hitting record. This provides context for what led up to a critical event.	X
Lens Field of View: 75°	AXON flex simply captures the officers direct visual perspective.	X
Date and Time Stamp: Set by NIST. Embedded in Video File.	Date and time cannot be altered. This protects the chain of custody.	
8 GB Flash Storage Capacity with Up to 12 hours Recording Time	When a critical event does occur, you will not run out of recording time.	X
MPEG-4 Layer 2 Recording Format	Playable on standard video playback devices	X
-20 Celsius to +55 Celsius Working Temperatures	You can trust AXON flex to operate even at these temperatures.	
IPX2-MIL-STD Water Testing	Weather won't stop AXON flex, even during rainy, blowing conditions.	
6' onto Hard Surface Drop testing	If an officer drops AXON flex, it is designed to hold up.	
Lithium-Ion (Non-Removable) Battery Type	Rechargeable batteries mean not having to buy tons of off-the-shelf batteries.	
12+ hours Battery Recording Life	Each officer's camera battery will last for their full 8 or 10 hour shift.	X
Physical Dimensions: Camera 3.2" x .7 x .8; Controller 3.3" x 2.6" x .8"	AXON flex offers several mounting options for law enforcement officers, including Oakley Glasses, Collar, Cap, Headband, Uniform clip, Alligator clip, Belt clips, Epaulette, Universal Magnet, and Helmet mount.	
Weight: Camera .53 oz. ; Controller 3.3 oz.	Weighs less than the typical officer's badge.	X
Simple one button Operation	No fumbling with complicated activations. This is a simple device with one record button.	
1 Year Manufacturer Warranty	1 year warranty comes free on AXON flex.	X

Tucson PD could decrease officer complaints by 87.5% and decrease officer use-of-force by 59% with AXON and EVIDENCE.com.²



AXON Flex system, shown with the Oakley Flack Jacket Mount option. This is one of over 10 mounting options TASER offers with the AXON flex.

Some of the features of our AXON flex and EVIDENCE.com are listed below.

- **Point-of-View Imaging** – the AXON flex camera is designed to be mounted around an officer’s head or neck. With other forms of on-officer video, the images don’t actually tell us what the officer is seeing from his direct visual perspective, which makes it difficult to determine whether his actions in the field were indeed justified. But the AXON Flex allows us to experience the event as it was apparent to officer, and lets the justice system adjudicate accordingly.
- **Multiple Mounting Options** - As we discovered, there is no one-size-fits all solution for law enforcement officers. The officer chooses what is best for him with TASER’s many mounting options. The AXON flex can be mounted on an officer’s Oakley’s eyewear, headband, collar, ball cap, epaulette, helmet, or virtually anywhere else he or she finds it comfortable. AXON flex offers several mounting options for law enforcement officers, including Oakley Glasses, Collar, Cap, Headband, Uniform clip, Alligator clip, Belt clips, Epaulette, Universal Magnet, and Helmet mount.
- **Recording Format: MPEG-4 Layer 2**
TASER’s AXON flex uses MPEG-4 Layer 2. MPEG-4 absorbs many of the features of MPEG-1 and MPEG-2 and other related standards contributing to this, adding new features such as (extended) VRML support for 3D rendering, object-oriented composite files (including audio, video and VRML objects), support for externally specified Digital Rights Management and various types of interactivity. MPEG-1 is an old technology

² Data presented in 2013 by Rialto PD Chief of Police William Farrar after a year-long, randomized scientific study of the effect of officers wearing AXON Flex and using EVIDENCE.com. The study was performed in conjunction with the University of Cambridge. The full case study can be found at the end of this proposal.

- **“Retina Low-Light” Imaging Technology** – in order to capture exactly what officers see, it is pivotal to purchase a camera that mimics the light-perception of the human retina. This is what the flex offers with its “retina low-light” technology. Other vendors will offer cameras that emit infrared-light, which can distort the scene as it appeared to the officer.
- **30-second Buffered Recording** – with the rise of YouTube and handheld recording devices, police officers are increasingly facing scrutiny for actions captured in five-second video clips. TASER understands that to protect the good name of law enforcement, it is critical for an officer’s camera to capture the events *leading up* to the critical incident—and not just the incident itself. The flex’s full-shift buffered recording feature automatically captures the thirty seconds prior to the activation of the camera – providing the proper context for an officer’s actions.
- **Automated Workflows** – our law enforcement can’t afford to waste time uploading files at the end of a long shift. With TASER’s EVIDENCE.com dock, this isn’t a problem: all an officer needs to do at the end of his shift is place his camera in the dock and go home. The video files are automatically uploaded to TASER’s backend system, EVIDENCE.com.
- **Battery Recording Life: 12+ Hours**
AXON flex has a battery life of 12+ hours. An officer’s typical shift lasts a full 12 hours, which means the competition’s battery may fall short while your officers are on duty. Our camera was designed with a battery to last the officer’s typical 12 hour shift. If a critical event happens, not having enough battery life left to capture it could be devastating.
- **Flash Storage Capacity: 8 GB Non-Removable**
AXON flex contains twice as much storage on the device as our competition: a full 8GB of memory. That means an officer can store twice as much video as the competition as well.
- **Recorded Video Capacity: 4+ hours**
AXON flex has a video recording capacity of up to 12 hours. This is a high value add for the department’s video program.
- **Water Testing: Waterproof IPX2 Certification.**
AXON flex complies with IPX2-MIL-STD Method 506.4. IPX2 protects against falling water (i.e. rain or other precipitation) from many angles.

- **Manufacturer Warranty:** One year on Camera and Controller, 90 days on accessories - AXON flex comes with a full year manufacturer's warranty. TASER stands by our camera for a full year and all accessories for 90 days. With most of the competition, Tucson PD will have to purchase an extended warranty in order to get the same warranty that TASER provides for free. Tucson PD could save thousands of dollars in warranty costs alone with AXON flex.
- **Security - EVIDENCE.com** has 99.999999999% data durability, our storage provider is CJIS compliant, and is compliant with FISMA.



EVIDENCE.COM – SIMPLE, TURN-KEY CLOUD SOFTWARE WITH SCALABILITY

EVIDENCE.com provides to law enforcement a robust solution for organizing, classifying, managing, viewing, and archiving digital evidence, whether that digital evidence be AXON videos, still images captured by digital cameras, or even PDF documents of interrogation transcripts. TASER's hosted solution is industry-standard secure, and it implements all the proper measures to protect chain of custody.



Screenshot of EVIDENCE.com interface

EVIDENCE.com can be accessed from any computer with an internet connection, so it isn't dependent on unreliable agency servers. Storing your agency's data in the cloud also allows the data to be easily shared with interested outside parties using EVIDENCE.com—the DA's office, for instance.

EVIDENCE.com is designed to integrate with existing law enforcement solutions such as CAD, RMS, and others, to provide a seamless workflow and reliable mechanism to manage all digital evidence within an organization. It is also, by nature, highly scalable—so

there aren't any constraints to expanding EVIDENCE.com utilization at your agency aside from the cost of storing data in "the cloud." All it takes to store evidence on this hosted solution are an AXON unit, and Evidence.com dock or USB cable, and EVIDENCE.com account.

Deploying EVIDENCE.com provides both tactical and strategic benefits to agencies. Some of these benefits include:

- **Automatic Upgrades to Latest Features**—the latest product features and enhancements are included as part of your investment in EVIDENCE.com. As far as you are concerned, this is a totally hands-off process: the EVIDENCE.com operations team at TASER applies these upgrades remotely, eliminating any worries about properly integrating or updating your systems.
- **Community of Interest**—a like-minded constituency influences and guides the direction of our product. Other EVIDENCE.com users are able to share best business practices within the user community, and leverage existing processes and experiences from other users.

- Your Agency's Partnership with TASER International—TASER partners with customers: from purchase through installation, support, and beyond—ensuring that each investment in TASER products returns the maximum value.

EVIDENCE.com is not only offers a unique and compelling solution to digital evidence storage, but the interface of the application itself integrates a bevy of advanced features. Some of these include an easy-to-use search function, the ability to group files according to case number, and marking certain files for automatic deletion after a pre-determined date.

VIDEO MANAGEMENT BACKEND SYSTEM

TASER's recommended workflow uses an EVIDENCE.com dock. The dock allows an officer to dock the AXON cameras in one place. As soon as the AXON camera is docked, videos on the camera automatically begin to download. The officer simply places the camera into the docks, as shown below. Not only does the dock allow for easy download, but it also charges the devices and if need be, upgrades the firmware versions without the need for a computer.

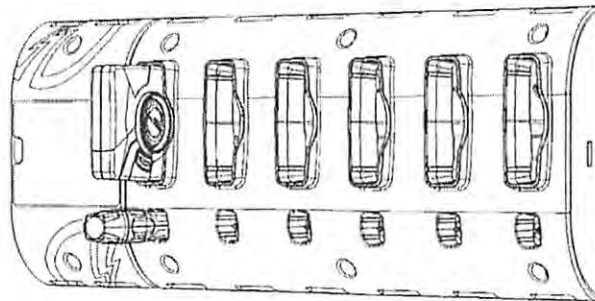

Evidence.com Dock which can download videos and charge up to six (6) AXON flex or body units simultaneously.

- Multi-charging / multi-docking station is not reliant upon a USB cable or individual computer. It has a RJ45 Ethernet connection.
- AXON videos are uploaded automatically once the DVR is docked into the EVIDENCE.com dock. Once in the dock, an encrypted 256-bit AES SSL session is established with EVIDENCE.com. AXON videos are then sorted and uploaded in an order of largest to smallest.

As a video is being uploaded it is broken into small blocks of approximately 2-3 megabytes in size. Prior to upload the block is hashed using the SHA1 algorithm to generate a unique fingerprint or checksum. The block is then uploaded to EVIDENCE.com, upon receipt the block is hashed again using the SHA1 algorithm, if an identical checksum is generated then the file's fingerprints match and the block is unaltered from its original state on the AXON body or flex.

The block upload process is repeated until the entire MP4 is transferred. Using the same method that was used to validate the blocks, a contiguous checksum of the entire file will be evaluated to ensure that the MP4 file has been uploaded successfully and identical to when it was recorded. Once EVIDENCE.com confirms receipt, the video is deleted from the DVR and the upload process moves to the next file.

- The EVIDENCE.com dock uploads one file from one camera at a time, then moves on to the next file on that camera. Once the first camera's files have all been transported to EVIDENCE.com, the dock begins uploading the next camera's files. In this way, the dock throttles itself. The City's IT department can also determine how much network pipe will be allowed by the dock- this can be set up relatively easily.
- Minimum 256 bit AES encryption in storage and transport
- Each unit has its own unique ID that can be registered to a specific Officer
- Capable of handling over 2000 user/officer accounts
- An administrator can determine the roles and actions of all users and create individual user accounts with varying degrees of access i.e. administrative accounts, basic user accounts.
- Digital Evidence is deleted either manually or through category based automation. Manual deletions are applied when an administrator designates a video for deletion. The video is then allowed a 7 day grace period in which to be recovered. The event is then expunged.

The automated deletion is reliant on the agency establishing retention categories. In the creation of categories, all types of categories are associated with a retention period. If no retention period is specified then video will remain on the system until manually deleted. If a category such as "Traffic Stop" is created with a retention period of 2 years, once a video is created, marked as a "Traffic Stop" and uploaded to EVIDENCE.com, the video will automatically be marked for deletion 2 years from the upload date. Administrators receive a weekly e-mail report notifying them of upcoming deletions that week. Audit trails for deleted events are always retained in order to show the life-cycle of the evidence even if expunged. EVIDENCE.com allows the System Administrator to create evidence categories with corresponding default lengths of retention in the

EVIDENCE.com database. The System Administrator can also delete evidence as necessary. All deleted evidence will be retrievable for 7 days. The evidentiary Audit Trail will be retained after the evidence is purged for the purpose of accountability. The Audit Trail will indicate if the file was removed manually or through retention via categories

- The original file uploaded to EVIDENCE.com is never altered.
- Officers can add metadata using TASER's free mobile app, AXON MOBILE. This application syncs to the camera via Bluetooth and allows the officer to add metadata in the field. After upload, the officer can also add metadata tags on EVIDENCE.com. The following is the complete list of metadata which can be captured by EVIDENCE.com:

EVIDENCE.COM allows for 11 indexing fields.

- D – Case ID of incident
- Uploaded By – User that uploaded content
- Owner – User currently assigned video i.e. if Officer A captures the video, but Officer B is conducting the investigation, Officer B only has access to view his own video. Said video can be assigned by an administrator to Officer B who can then review the video captured by Officer A.
- Title – Titles are defaulted to the date and time of the video capture "Flex Video 2012-10-13 1447." This field can be updated by the user at the time of capture to display a more specific title i.e. "Boat Crash at Lake of the Ozarks."
- From – Initial date to start search from
- To – Last date to search from
- Category Based Fields:
- Date – Allows searching based on Recorded Date, Upload Date, and Delete Date
- File Type – Allows searching for any digital media type or to specify type such as Video, Audio, Document, Image, Firing Log, and Other
- Status – Allows searching for any status level or to specify type such as Active, Processing, Queued for Deletion, Excluded, and Deleted
- Flagged – Allows searching for any flag level or to specify type such as Flagged or Unflagged.
- Category – Allows searching for any category type or to specify any category added by the agency.

Device Searches index the following fields:

- Model - All AXON Cameras, ETM and ECD
- Serial Number
- Device Status - Any, Active, Inactive, Stolen, RMA, Lost, Stolen
- Error Status - Any, Good, Minor, Major, Critical
- Last Upload Data From
- Last Upload Data To
- Device Name
- Device Assigned to

User Searches Index the following fields:

- Last Name
 - First Name
 - Role
 - Date - Last Active, Invited, Deactivated
 - Status - All, Active, Invited, Deactivated
 - From
 - To
 - Badge Number
-
- EVIDENCE.com takes all types of image and video files, including but not limited to: DIVX, TS, 3GP, ASF, AVI, FLV, MOV, MP4, RM, VOB, WMV, F4V, MPEG, and MPG. This will allow Tucson PD to store additional video data from other mediums such as in-car video cameras and mounted surveillance cameras.

- Video Redaction. The best way to describe how EVIDENCE.com manages video is through layers. The two bottom layers are the original video and audio. Those two layers are never tampered with or manipulated. When we apply markers, clips, or redaction they exist in layers above the original content. The best way to imagine this would be to picture a translucent sheet over a picture or painting. Drawing on the sheet, and then removing the sheet. This leaves you with an un-altered original image.

When a user applies redaction to a video, all of their actions are saved to an XML file, much like the translucent sheet. When the video is played back the sheet is layered back over the video. Even when a redacted video is exported from EVIDENCE.com, the video is created (encoded) on the fly and saved to the local hard drive.

- The camera itself is not capable of taking still photos. However TASER's free smartphone app EVIDENCE Mobile can take still images and upload them to your EVIDENCE.com account and still images can be collected after upload using EVIDENCE.com.

- Audit tracking and reporting functions. TASER's complete on-officer video and evidence management systems safeguard against a break in the chain of custody. EVIDENCE.com automatically logs a detailed Evidence Audit Trail of anything that happens to that video or its metadata. The log can be used to determine a chain of custody that surpasses chain of custody regulations. EVIDENCE.com logs an Audit Trail for every piece of digital evidence. Below is an example of an Audit Trail on a single piece of video evidence.

Taser Information

Dept. TASER Demo Site
 Title 12-090998

Report Generated by

Name Midwest, Officer (32921)
 Username Midwest
 Local Time zone US Mountain Standard Time (UTC -07:00)
 Generated On 07 Sep 2012 12:42:47

Case ID: CA-5721FFE5131D4872B2E3F634F9320D92

#	Date	Time	User	Activity
1	28 Aug 2012	12:42:47 (-07:00)	Northern, Officer (23470) Username: Northern	Created
2	28 Aug 2012	12:42:48 (-07:00)	Northern, Officer (23470) Username: Northern	Viewed
3	28 Aug 2012	12:43:03 (-07:00)	Northern, Officer (23470) Username: Northern	Tag 'DUI' Added
4	28 Aug 2012	12:43:09 (-07:00)	Northern, Officer (23470) Username: Northern	Tag 'Jones' Added
5	28 Aug 2012	12:43:25 (-07:00)	Northern, Officer (23470) Username: Northern	Annotation Added or Updated
6	28 Aug 2012	12:43:35 (-07:00)	Northern, Officer (23470) Username: Northern	Folder 'Video interviews' Added
7	28 Aug 2012	12:43:45 (-07:00)	Northern, Officer (23470) Username: Northern	Folder 'Audio Interviews' Added
8	28 Aug 2012	12:43:54 (-07:00)	Northern, Officer (23470) Username: Northern	Folder 'Crime scene photos' Added

- Enhanced Multi-file Uploader. Users can now enter a different Title, ID and Category for each file they upload in the Import Evidence section of Evidence.com. Users simply select the evidence (audio, video, picture, etc.) from their computer they want to upload to their account or simply drag and drop the files into the designated area.

FILE SHARING

Any file stored on EVIDENCE.com can be shared with interested parties. Individual files and entire case files can be shared with outside EVIDENCE.com users directly from the online interface. This feature can be particularly helpful when coordinating with, say, a District Attorney's office for litigation purposes. These files can be shared for a set period of time, and when the audit trail logs access and views.

- Custom storage set-up options and automatic delete to never delete parameters
Saving storage space via an automatic deletion policy is remarkably simple with EVIDENCE.com. Before you even record a single AXON video, account administrators may pre-set how long they would like each file to be stored until it is deleted by the system. Of course, these retention periods may always be adjusted for individual files after they have been uploaded to the EVIDENCE.com system, which will be useful if a particularly critical incident is captured and must be stored on file indefinitely. And if recently deleted files are still needed, then a “remorse period” ensures that those files can still be retrieved within a seven-day timeframe.

The automated deletion is reliant on the agency establishing retention categories. In the creation of categories, all types of categories are associated with a retention period. If no retention period is specified, then video will remain on the system until manually deleted. If a category such as “Traffic Stop” is created with a retention period of 2 years, once a video is created, marked as a “Traffic Stop” and uploaded to EVIDENCE.com, the video will automatically be marked for deletion 2 years from the upload date. Administrators receive a weekly e-mail report notifying them of upcoming deletions that week. Audit trails for deleted events are always retained in order to show the life-cycle of the evidence even if expunged.

Tucson PD users designated as Administrators will have full control of the classification system. TASER suggests a few classifications, such as “Traffic Stop” or “Domestic Dispute,” but Tucson PD can customize the classifications as needed. There are many different ways to handle deletion, but the Administrators can remove any user’s ability to delete a record from the system. There are also automated deletion periods which can be built into the system, which were discussed in the above “DELETING/PURGING” section. Audit trail capabilities are also discussed in detail on the previous page.

Development of the Digital Evidence Workflow (DEW)

DIGITAL EVIDENCE WORKFLOW (DEW) FRAMEWORK



After consulting with agencies across the country, TASER International created the Digital Evidence Workflow (DEW) framework. The DEW Framework was designed to help agencies make sense of complicated and complex systems and highlight areas where they could improve their efficiency and effectiveness.

THE DEW FRAMEWORK DEFINED

Across all digital evidence workflows, TASER identified five general phases that usually take place independent of the capture device. Those phases of the DEW Framework are:

- Capture/Collect
- Ingest/Transfer
- Manage/Store
- Retrieve
- Share

DIGITAL EVIDENCE WORKFLOW (DEW) FRAMEWORK

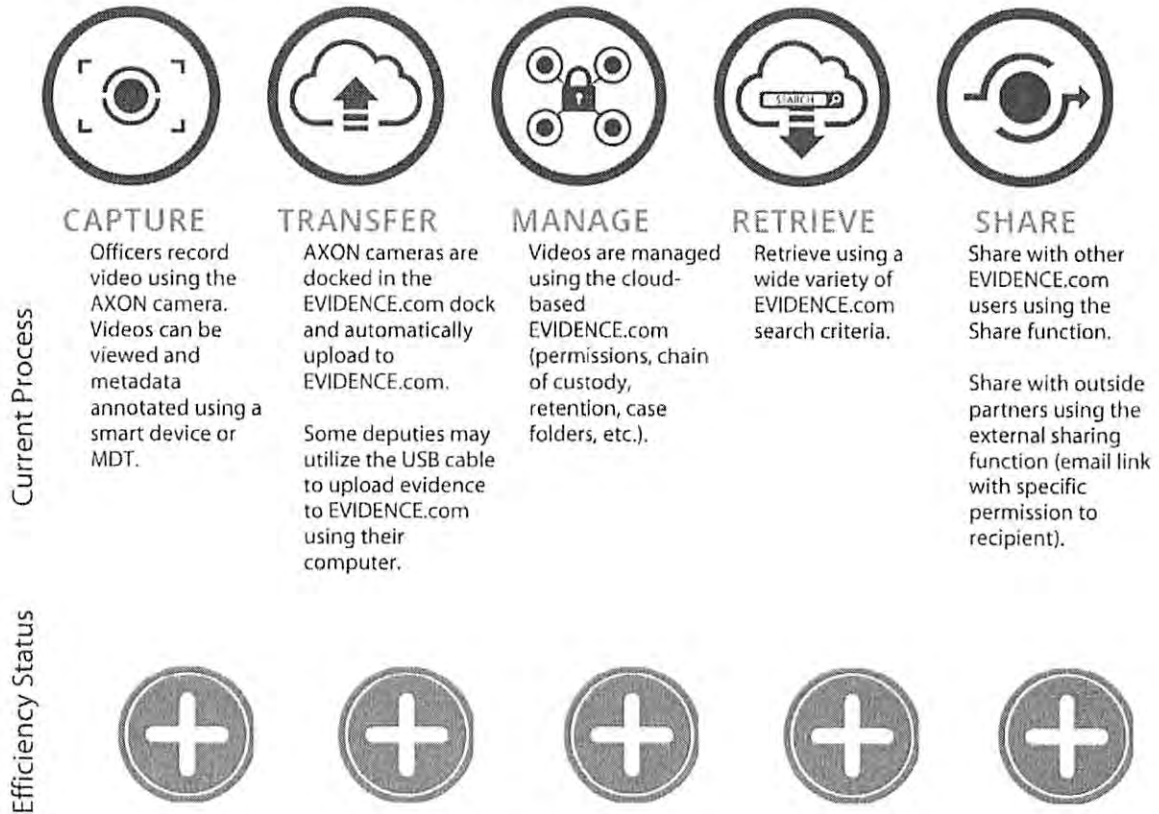

INDUSTRY BEST PRACTICES

The Capture/Collect phase is the most visible and generally best understood stage of the DEW. During this stage, devices simply capture and collect the digital evidence. Examples are in-car video systems, on-officer video cameras, digital cameras and audio recorders. There are several important factors that an agency should consider when selecting a capture device such as power requirements, quality and dependability.

The Ingest/Transfer stage is frequently one of the most overlooked phases of the DEW. During this phase agencies must take the digital evidence that has been captured and either ingest or transfer the digital evidence into a management system. The most efficient way to deal with this is through automation, but many capture devices do not offer this capability. In the IACP report, "Technology Technical Assistance Program on In-Car Cameras," it is stated that "underestimating workload and costs were common problems experienced by the majority of

agencies that participated in this IACP Study.³ Many, if not most, agencies use the same workflow to ingest digital evidence that they created decades ago for ingesting physical evidence: officers must physically return with the capture device to a centralized evidence repository where it is usually transferred to another digital medium and stored on shelves.

The **Manage/Store** phase is one that all agencies are aware must occur but they are often ill equipped to handle the storage and management of digital evidence. Indeed, the Commission on Accreditation for Law Enforcement Agencies (CALEA) standards highlight that “the products of these technologies could become an important piece of evidence in any type of case and should be maintained in a way to insure the integrity of contents.”⁴ While some law enforcement agencies do have a vendor supplied or in-house developed digital information management system the cost of maintaining, securing and backing up such a system can be prohibitive.

The **Retrieve** phase is one of the most overlooked stages in that agencies frequently underestimate the amount of time it will take to find a piece of digital evidence. There are several different approaches to managing and storing digital evidence, each of which affects the retrieval process. For example, tagging a DVD with a barcode or case number and sticking it on a shelf in an evidence room or a storage warehouse can result in lengthy search and retrieval times. A single CD of evidence related to a case can contain a hundred or more images, each of which might pertain to a different aspect of the case. Trying to find the right images will require going through all one hundred or more images. If, on the other hand, the images were stored in a database and tagged individually with identifiers other than just the case number, they could be retrieved with a simple search within seconds. So a best practice is to have a system that has an advanced search function using multiple identifiers for each piece of digital evidence.

The **Share** phase of the process involves getting the digital evidence to the correct stakeholders when requested. One of the benefits of digitally stored evidence is that it can be securely moved to the requestor via the Internet. The banking industry realized enormous efficiency gains in the mid-to-late 90s by automating several of their processes securely over the Internet. In researching law enforcement’s use of Internet-based automation in sharing digital evidence we discovered that only a very small minority of agencies today are taking advantage of this technology, resulting in mounting costs of digital evidence sharing. For example, a typical evidence room in the average police department requires one or more forms to request copies of digital evidence. That evidence first needs to be found, then copied (usually multiple copies are made) and finally hand delivered to the recipient, such as a prosecutor or defense attorney. A single request for evidence can take hours to complete and the manual transport of copies to be shared wastes numerous hours of officers’ time that could otherwise be spent on the street. Finally, manual sharing of digital evidence frequently leads to lost copies, resulting in the entire process having to be repeated at additional cost.

³ IACP/COPS Technology Technical Assistance Program (2004) – Page 60, Paragraph 2

⁴ <http://www.calea.org/content/standards>

Agencies across the country helped TASER to understand their needs when equipping on-officer video. The following subjects have been strongly influenced by customer use of on-officer video in the field.

All video stored in a central location.

TASER's proposed workflow includes direct transfer to a PC or through the use of our Evidence.com dock. The data is then transferred to the location of the agency's choosing. AXON videos can be stored wherever the department desires. With TASER's solution, the decision on the storage of digital evidence is completely Tucson PD's.

System prevents user from Deleting or Editing Original Video File.

AXON videos cannot be deleted from the camera.

AXON videos are downloaded automatically once the DVR is docked into the EVIDENCE.com dock. Once in the dock an encrypted 256-bit AES SSL session is established with the local storage device. Videos are then sorted and uploaded in an order of largest to smallest.

As a video is being downloaded it is broken into small blocks of approximately 2-3 megabytes in size. Prior to upload the block is hashed using the SHA1 algorithm to generate a unique fingerprint or checksum. The block is then downloaded to your storage device, upon receipt the block is hashed again using the SHA1 algorithm, if an identical checksum is generated then the file's fingerprints match and the block is unaltered from its original state on the AXON.

The block upload process is repeated until the entire MP4 is transferred. Using the same method that was used to validate the blocks, a contiguous checksum of the entire file will be evaluated to ensure that the MP4 file has been uploaded successfully and identical to when it was recorded. Once your storage device confirms receipt, the video is deleted from the DVR and the upload process moves to the next file.

TASER has a full customer support division. We offer webinars and training on our website 24/7, and live phone support Monday-Friday, 7:00AM – 5:00PM MST. Specific department leaders are:

EVIDENCE.COM: ADVANCED FEATURES

EVIDENCE.com provides a number of unique, pivotal features that facilitates evidence management and coordination. To begin with, account administrators can customize the roles and authorization levels of each member of the agency's account, both to preserve chain of custody and to clarify what each user is permitted to do.

To help find files stored on your EVIDENCE.com account, TASER offers a powerful search feature based on the name of the officer, the date the file was recorded or uploaded, the device moniker, etc.—this alone gives EVIDENCE.com a leg up to over most file management competitors.

Once you find the files you are looking for, you can begin to group them around larger case files—the most commonsense way to manage evidence.

Each file is capable of carrying “Intelligent Video Attributes”—basically information about the context of the video. These attributes could include GPS coordinates, the time it was recorded, the officer and device that recorded it, which case file it belongs to, etc. Each of these attributes making later searches and retrievals easier. Users can also clip out smaller segments of larger video files, in order to let the viewer see only the most significant moments of a recorded video.

EVIDENCE.com Functionalities

- ✓ Configurable Roles and Permissions
- ✓ Power Search Feature
- ✓ Files Grouped Around Case Numbers
- ✓ Intelligent Video Attributes
- ✓ Automated Retention Policies
- ✓ Seven-day Remorse Period
- ✓ Easy Sharing among Users

Saving storage space via an automatic deletion policy is remarkably simple with EVIDENCE.com. Before you even record a single AXON video, account administrators may pre-set how long they would like each file to be stored until it is deleted by the system. Of course, these retention periods may always be adjusted for individual files after they have been uploaded to the EVIDENCE.com system, which will be useful if a particularly critical incident is captured and must

be stored on file indefinitely. And if recently deleted files are still needed, then a “remorse period” ensures that those files can still retrieved within a seven-day timeframe.

Perhaps the most exciting of these features is the ease with which any file stored on EVIDENCE.com can be shared with interested parties. Individual files and entire case files can be shared with outside EVIDENCE.com users directly from the online interface. This feature can be particularly helpful when coordinating with, say, a District Attorney's office for litigation purposes.

EVIDENCE MOBILE

EVIDENCE Mobile is a free mobile application that allows officers to capture, tag and upload evidence with a few taps of the screen. It turns the officer's smart phone or touch screen device into a camera and audio recorder that seamlessly and securely integrates with EVIDENCE.com.

- All the Evidence, One Device - Capture photos, audio, and video using a mobile device.
- Upload from Anywhere - EVIDENCE.com data transfer directly from the field over any data or Wi-Fi connection.
- Get More from Your Evidence - Quickly tag data with time and date of capture, unique Title, incident ID, event category, and GPS location in the field.
- Operating System - Currently Available Through the Google Play Store for Android Devices Version 2.2 and above. Available through iTunes for Apple iOS Devices in Early 2013
- Upload Method - Upload Data via Any 3G or 4G Data Connection, or via a Wi-Fi Connection
- Access - Users Must Log In to Their Active EVIDENCE.com Account to Use the Application
- Storage - The Application Will Only Upload Data to EVIDENCE.com Secured Storage

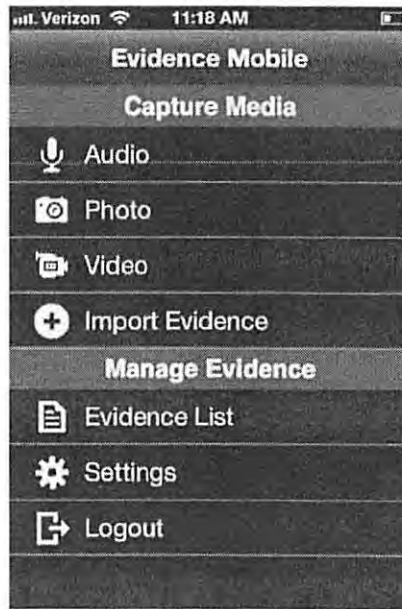

Screenshots from TASER's EVIDENCE mobile app.

Capture

Capture digital evidence in the form of videos, photographs, and audio recordings from user's mobile device.

Upload & File on the Go

Upload, tag and add information to digital evidence through the same device while on the go.

EVIDENCE.com Integration

This simple to use, end-to-end solution will manage digital data when paired with EVIDENCE.com.

GPS Tagging

Add device GPS data to evidence.

Security

Security pin protects evidence if device is stolen or lost.

Customize App Settings

Allows users to decide deletion policies, upload methods, GPS tagging, security and more.

Cost Control

Fit the app to your data plan; set maximums for the size of files uploaded via a data connection or upload only over Wi-Fi.

Savings

Never buy or carry another digital camera or audio recorder again.

Evidence Sync

EVIDENCE Sync allows officers to manage digital evidence and TASER® products from any computer with an internet connection, including an MDT. Use Sync to preview, annotate and upload digital evidence from any source to EVIDENCE.com, plus manage your agency's TASER products and update firmware. And as always, your data is secure and easy to access at any point.

- **Any File, Any Source** – Upload any audio, video, photo or other files currently on CDs, memory cards, servers or a hard drive to EVIDENCE.com.
- **Handsfree Transfer**- Select the data to upload to EVIDENCE.com, then log out and walk away while the app keeps working.
- **Upload Any Digital Evidence** - Upload any format and size of photo, video or audio recording.
- **Manage TASER Products** – Collect evidence, change settings, assign, and update firmware for your CEWs or AXON® cameras.
- **Add Metadata** – Add Metadata Tag evidence with Title, Event ID, and Category, and assign evidence at upload
- **Schedule Uploads** – Select a folder or file on your hard drive or network to upload at set times.
- **Upload from Servers** – Upload interview room or dash-cam videos from shared drives.
- **Upload from Camera, CD or SD Card** – Upload crime scene photos from any source.
- **Upload from the Field** – Run the app from your MDT and access from the field.
- **Walk Away During Uploads** – Log out while uploads keep going in the background.
- **View Files in a Gallery** – View Files in a Gallery Quickly manage photos and videos using thumbnails.
- **Search Easily** – Find any file and search by title, date, keyword or other fields.



Appendix A – Reporting

TASER's EVIDENCE.com storage solution allows an administrator or officer to produce hundreds of searching and reporting options, based on their permission level. EVIDENCE.com has pre-set categories however agencies can add customized categories based on their existing agency guidelines and protocols.

Listed below are some sample screen shots and reporting functionalities.

Dashboard

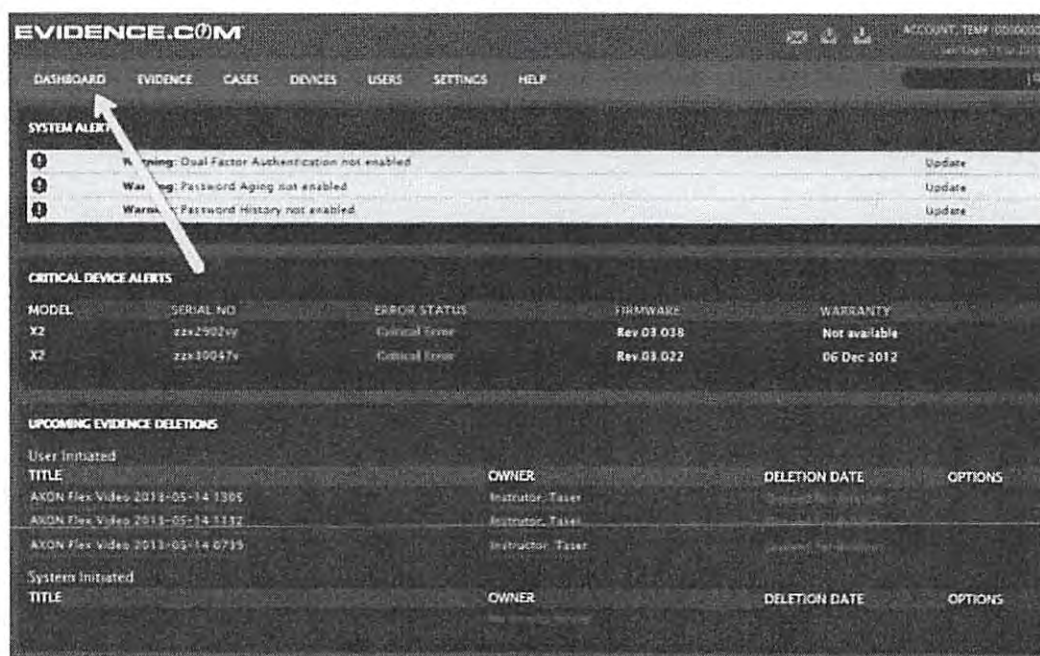

The screenshot displays the EVIDENCE.COM dashboard interface. At the top, there is a navigation menu with tabs for DASHBOARD, EVIDENCE, CASES, DEVICES, USERS, SETTINGS, and HELP. The DASHBOARD tab is selected and highlighted with a white arrow. The dashboard content is divided into several sections:

- SYSTEM ALERTS:** A list of three warning messages with 'Update' links.
 - Warning: Dual Factor Authentication not enabled
 - Warning: Password Aging not enabled
 - Warning: Password History not enabled
- CRITICAL DEVICE ALERTS:** A table listing device models, serial numbers, error statuses, firmware versions, and warranty information.
- UPCOMING EVIDENCE DELETIONS:** A table listing deletion events initiated by users or systems, including titles, owners, deletion dates, and options.

MODEL	SERIAL NO	ERROR STATUS	FIRMWARE	WARRANTY
X2	z2x2902vy	Critical Error	Rev 03 038	Not available
X2	z2x30047v	Critical Error	Rev 03 022	06 Dec 2012

UPCOMING EVIDENCE DELETIONS				
User Initiated				
TITLE	OWNER	DELETION DATE	OPTIONS	
AXON Flex Video 2012-05-14 1305	Instructor, Taser	2012-05-14 1305		
AXON Flex Video 2012-05-14 1312	Instructor, Taser	2012-05-14 1312		
AXON Flex Video 2012-05-14 0739	Instructor, Taser	2012-05-14 0739		
System Initiated				
TITLE	OWNER	DELETION DATE	OPTIONS	

The Dashboard tab will always bring you back to the home page.

Evidence

The screenshot shows the EVIDENCE.COM dashboard with a navigation menu at the top. The 'EVIDENCE' tab is highlighted with a white arrow. Below the navigation menu, there are three sections: 'SYSTEM ALERTS', 'CRITICAL DEVICE ALERTS', and 'UPCOMING EVIDENCE DELETIONS'.

SYSTEM ALERTS

Alert Type	Message	Action
Warning	Disk Sector Authentication not enabled	Update
Warning	Password Aging not enabled	Update
Warning	Password History not enabled	Update

CRITICAL DEVICE ALERTS

MODEL	SERIAL NO.	ERROR STATUS	FIRMWARE	WARRANTY
X2	xxx23927x	Critical Error	Rev 03 038	Not available
X2	xxx30047x	Critical Error	Rev 03 022	06 Dec 2012

UPCOMING EVIDENCE DELETIONS

Initiated By	TITLE	OWNER	DELETION DATE	OPTIONS
User Initiated				
	AXON Flex Video 2013-05-14 1305	Inspector, Taser	2013-05-14 1305	
	AXON Flex Video 2013-05-14 1132	Inspector, Taser	2013-05-14 1132	
	AXON Flex Video 2013-05-14 0739	Inspector, Taser	2013-05-14 0739	
System Initiated				
		OWNER	DELETION DATE	OPTIONS

The Evidence tab, will allow importing evidence, viewing personal and shared evidence, and allow for search capabilities.

Manually Uploading Evidence

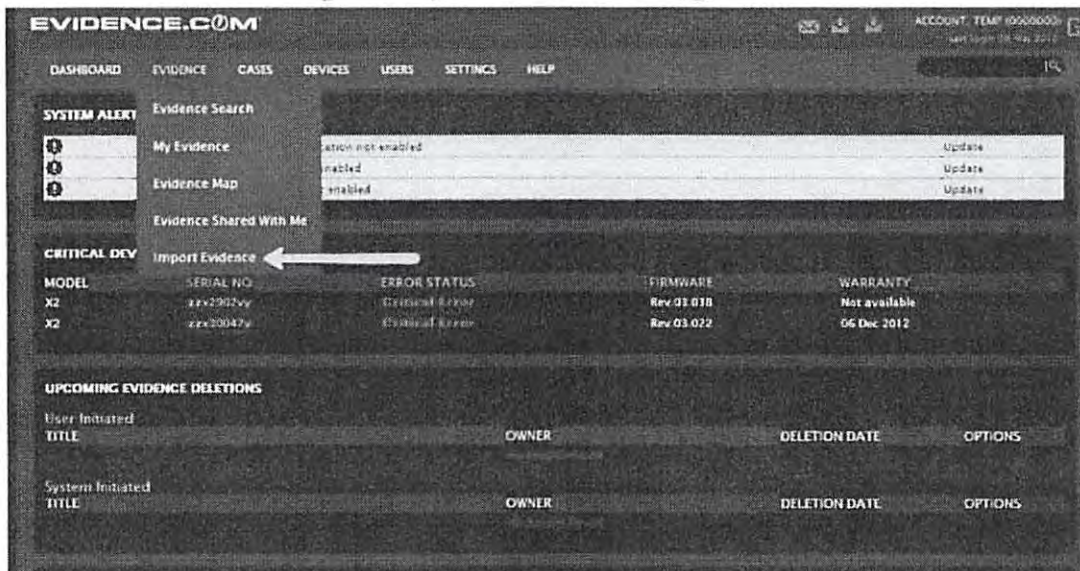

There is an option to manually import digital evidence

Evidence

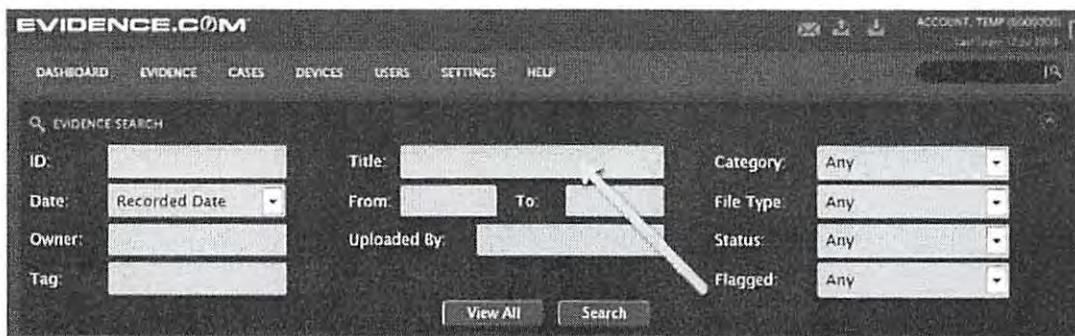

The Evidence Search will offer filter searching through the data directory for specific evidence or generic.

Cases

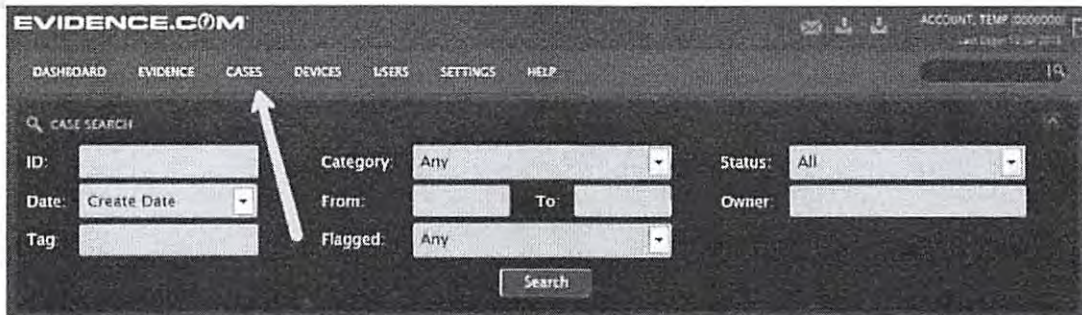

The Cases tab will allow viewing of personal account cases, search, create, and share cases with other users in the agency.

Devices

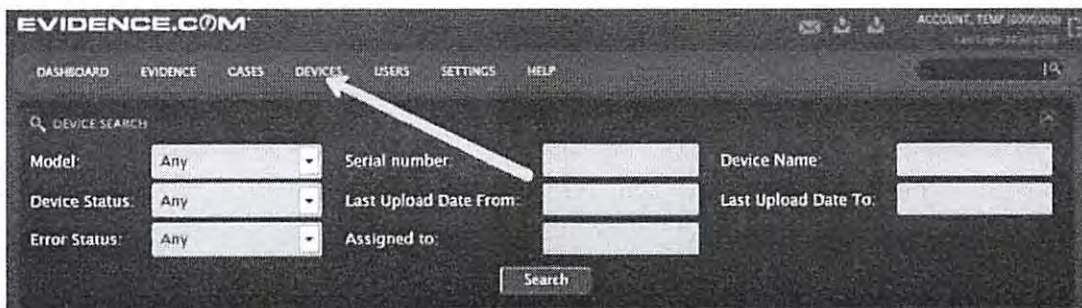

The Device tab allows searching for specific device throughout the agency. This includes AXON products and CEWs.

Searching for Devices

The screenshot shows the EVIDENCE.COM web application interface. At the top, there is a navigation menu with options: DASHBOARD, EVIDENCE, CASES, DEVICES, USERS, SETTINGS, and HELP. The user is logged in as ACCOUNT TEMP (0000000) and the last login was on 12/04/2014. Below the navigation is a search bar and a 'DEVICE SEARCH' section. The search filters include: Model (Any), Device Status (Any), Error Status (Any), Serial number (78), Last Upload Date From (empty), Last Upload Date To (empty), and Assigned to (empty). A 'Search' button is located below the filters. Below the search filters, there is a table with 217 records found. The table has columns: MODEL, SERIAL NO., DEVICE NAME, DEVICE STATUS, ERROR STATUS, LAST UPLOAD, ASSIGNEE/LAST ISSUED, FIRMWARE, and WARRANTY. The first row of the table is highlighted with a white arrow pointing to the 'DEVICE NAME' column.

MODEL	SERIAL NO.	DEVICE NAME	DEVICE STATUS	ERROR STATUS	LAST UPLOAD	ASSIGNEE/LAST ISSUED	FIRMWARE	WARRANTY
AXON FLEX	X78000694	X78002604	Inactive	N/A	N/A	N/A		N/A
AXON FLEX	X78002660	X78002660	Inactive	N/A	08 Nov 2012	Instructor, Master	Rev. 1.4.0-A47T-RC	08 Jan 2014
AXON FLEX	X78002685	X78002685	Inactive	N/A	12 Nov 2012	Instructor, Master	Rev. 1.4.0-A46T	24 Jan 2014
AXON FLEX	X78003095	X78003095	Active	N/A	N/A	N/A	Rev. 1.4.0-A48T	27 Dec 2013
AXON FLEX	X78005446	X78005446	Inactive	N/A	08 Nov 2012	Instructor, Master	Rev. 1.4.0-A47T-RC	15 Jan 2014

To search for a device, use the filter boxes to help narrow down the search.

DEMC

EVIDENCE.COM

Scottsdale, AZ, US

Document generated: 06 Oct 2014 - 12:46:38 -07:00 by [redacted] Fabian([redacted])

EVIDENCE AUDIT TRAIL

Evidence	Source
Case ID	Device Type: None
Categories	Device Name: None
Title: [redacted] MD DUI	Serial Number: None
	Other: Imported
Recorded: 09 Jan 2014 08:45:30	
Uploaded: 09 Jan 2014 08:45:30	Usage
Uploader: [redacted], Fabian (Badge ID: [redacted])	
Evidence ID: 450358614D724BDCAAD270B403E6C822	Page views: 48
	File downloads: 2
	Video playbacks: 29
	Last Viewed Or Downloaded On: 06 Oct 2014 12:46:38

#	Date	Time	User	Activity
1	09 Jan 2014	08:45:30 (-07:00)	System	Evidence Record Created
2	09 Jan 2014	08:45:46 (-07:00)	System	Evidence Upload Completed Successfully.
3	09 Jan 2014	08:55:09 (-07:00)	[redacted] Fabian (Badge ID: [redacted]) Username: [redacted]	Evidence Record Added to Case 'dui'
4	09 Jan 2014	08:55:51 (-07:00)	[redacted] Fabian (Badge ID: [redacted]) Username: FMarrero	Evidence Record Added to Case 'dui' Folder 'AXON FLEX'
5	10 Jan 2014	08:55:00 (-07:00)	[redacted] Todd (Badge ID: [redacted]) Username: [redacted]	Evidence Record Accessed. Client IP Address: 70.192.2.219
6	10 Jan 2014	08:55:32 (-07:00)	[redacted] Todd (Badge ID: [redacted]) Username: [redacted]	Evidence Record Streamed. Client IP Address: 70.192.2.219
7	13 Jan 2014	10:39:18 (-07:00)	[redacted] Joe (Badge ID: [redacted]) Username: [redacted]	Evidence Record Accessed. Client IP Address: 69.69.103.250
8	13 Jan 2014	10:39:22 (-07:00)	account, temp (Badge ID: [redacted]) Username: Instructor15	Evidence Record Accessed. Client IP Address: 69.69.103.250
9	13 Jan 2014	10:39:35 (-07:00)	[redacted] Joe (Badge ID: [redacted]) Username: [redacted]	Evidence Record Streamed. Client IP Address: 69.69.103.250
10	13 Jan 2014	10:39:40 (-07:00)	account, temp (Badge ID: [redacted]) Username: [redacted]	Evidence Record Streamed. Client IP Address: 69.69.103.250
11	13 Jan 2014	10:40:36 (-07:00)	account, temp (Badge ID: [redacted]) Username: [redacted]	Evidence Record Accessed. Client IP Address: 69.69.103.250
12	13 Jan 2014	10:41:04 (-07:00)	account, temp (Badge ID: [redacted]) Username: [redacted]	Evidence Record Streamed. Client IP Address: 69.69.103.250
13	13 Jan 2014	10:45:57 (-07:00)	[redacted] Joe (Badge ID: [redacted]) Username: [redacted]	Marker Added

#	Date	Time	User	Activity
14	13 Jan 2014	10:46:25 (-07:00)	account, temp (Badge ID: [REDACTED]) Username: [REDACTED]	Evidence Record Accessed. Client IP Address: 69.69.103.250
15	13 Jan 2014	10:46:40 (-07:00)	[REDACTED] Joe (Badge ID: [REDACTED]) Username: [REDACTED]	Video Clip Added: "Confession" (00:02:06 to 00:02:56)
16	13 Jan 2014	11:04:19 (-07:00)	account, temp (Badge ID: [REDACTED]) Username: [REDACTED]	Evidence Record Accessed. Client IP Address: 69.69.103.250
17	13 Jan 2014	11:04:28 (-07:00)	account, temp (Badge ID: [REDACTED]) Username: [REDACTED]	Evidence Record Downloaded; Internal Record ID: FILE:8F6696533A9E4E82A0D224509D0E55BA@54716D8A AFBB4F1D8D69DC6028D6B53C Client IP Address: 69.69.103.250
18	13 Jan 2014	11:09:51 (-07:00)	[REDACTED] Joe (Badge ID: [REDACTED]) Username: [REDACTED]	Evidence Record Accessed. Client IP Address: 69.69.103.250
19	13 Jan 2014	11:29:17 (-07:00)	[REDACTED] Joe (Badge ID: [REDACTED]) Username: [REDACTED]	Evidence Record Accessed. Client IP Address: 69.69.103.250
20	13 Jan 2014	11:29:49 (-07:00)	[REDACTED] Joe (Badge ID: [REDACTED]) Username: [REDACTED]	Annotation 'Viewed prep for deposition' Added
21	16 Jan 2014	17:26:05 (-07:00)	[REDACTED] Fabian (Badge ID: [REDACTED]) Username: [REDACTED]	Evidence Record Accessed. Client IP Address: 173.226.125.243
22	16 Jan 2014	17:26:32 (-07:00)	[REDACTED] Fabian (Badge ID: [REDACTED]) Username: [REDACTED]	Evidence Record Streamed. Client IP Address: 173.226.125.243
23	20 Jan 2014	11:12:29 (-07:00)	[REDACTED] Fabian (Badge ID: [REDACTED]) Username: [REDACTED]	Evidence Record Accessed. Client IP Address: 173.226.125.243
24	23 Jan 2014	15:57:41 (-07:00)	[REDACTED] Christopher (Badge ID: [REDACTED]) Username: [REDACTED]	Evidence Record Accessed. Client IP Address: 66.119.2.33
25	23 Jan 2014	15:57:50 (-07:00)	[REDACTED] Christopher (Badge ID: [REDACTED]) Username: [REDACTED]	Evidence Record Streamed. Client IP Address: 66.119.2.33
26	24 Jan 2014	14:16:45 (-07:00)	[REDACTED] Fabian (Badge ID: [REDACTED]) Username: [REDACTED]	Evidence Record Accessed. Client IP Address: 173.226.125.243
27	24 Jan 2014	14:17:12 (-07:00)	[REDACTED] Fabian (Badge ID: [REDACTED]) Username: [REDACTED]	Shared with [REDACTED]@gmail.com with permissions to View, View Audit Trail. Share expires on 31 Jan 2014 14:17:11 (- 07:00)
28	24 Jan 2014	14:18:23 (-07:00)	[REDACTED] Fabian (Badge ID: [REDACTED]) Username: [REDACTED]	Removed sharing with [REDACTED]@gmail.com
29	24 Jan 2014	14:18:24 (-07:00)	[REDACTED] Fabian (Badge ID: [REDACTED]) Username: [REDACTED]	Shared with [REDACTED]@gmail.com with permissions to View, Download. Share expires on 31 Jan 2014 14:18:23 (-07:00)
30	06 Feb 2014	14:46:53 (-07:00)	Account, Temp (Badge ID: [REDACTED]) Username: [REDACTED]	Evidence Record Accessed. Client IP Address: 173.226.125.243
31	06 Feb 2014	15:16:10 (-07:00)	Account, Temp (Badge ID: [REDACTED]) Username: [REDACTED]	Evidence Record Accessed. Client IP Address: 173.226.125.243
32	06 Feb 2014	15:16:28 (-07:00)	Account, Temp (Badge ID: [REDACTED]) Username: [REDACTED]	Evidence Record Streamed. Client IP Address: 173.226.125.243
33	16 Feb 2014	19:19:48 (-07:00)	Account, Temp (Badge ID: [REDACTED]) Username: [REDACTED]	Evidence Record Accessed. Client IP Address: 68.204.148.37
34	16 Feb 2014	19:20:18 (-07:00)	Account, Temp (Badge ID: [REDACTED]) Username: [REDACTED]	Evidence Record Streamed. Client IP Address: 68.204.148.37
35	17 Feb 2014	10:21:52 (-07:00)	Account, Temp (Badge ID: [REDACTED]) Username: [REDACTED]	Evidence Record Accessed. Client IP Address: 71.99.73.155
36	17 Feb 2014	10:22:11 (-07:00)	Account, Temp (Badge ID: [REDACTED]) Username: [REDACTED]	Evidence Record Streamed. Client IP Address: 71.99.73.155
37	17 Feb 2014	10:22:15 (-07:00)	Account, Temp (Badge ID: [REDACTED]) Username: [REDACTED]	Evidence Record Accessed. Client IP Address: 75.112.148.13
38	17 Feb 2014	10:22:31 (-07:00)	Account, Temp (Badge ID: [REDACTED]) Username: [REDACTED]	Evidence Record Streamed. Client IP Address: 75.112.148.13

#	Date	Time	User	Activity
39	17 Feb 2014	10:31:29 (-07:00)	[REDACTED] Fabian (Badge ID: [REDACTED]) Username: [REDACTED]	Evidence Record Accessed. Client IP Address: 75.112.148.13
40	17 Feb 2014	10:31:35 (-07:00)	[REDACTED] Fabian (Badge ID: [REDACTED]) Username: [REDACTED]	Evidence Record Streamed. Client IP Address: 75.112.148.13
41	21 Feb 2014	10:07:42 (-07:00)	[REDACTED] Fabian (Badge ID: [REDACTED]) Username: [REDACTED]	Evidence Record Accessed. Client IP Address: 173.226.125.243
42	21 Feb 2014	10:07:57 (-07:00)	[REDACTED] Fabian (Badge ID: [REDACTED]) Username: [REDACTED]	Evidence Record Streamed. Client IP Address: 173.226.125.243
43	21 Feb 2014	10:08:21 (-07:00)	[REDACTED], Fabian (Badge ID: [REDACTED]) Username: [REDACTED]	Video Clip Added: "Redaction Masks" (00:00:00 to 00:04:20)
44	21 Feb 2014	10:11:22 (-07:00)	[REDACTED] Fabian (Badge ID: [REDACTED]) Username: [REDACTED]	Video Clip Edited: "Redaction Masks" (00:00:00 to 00:04:20)
45	21 Feb 2014	10:11:41 (-07:00)	[REDACTED] Fabian (Badge ID: [REDACTED]) Username: [REDACTED]	Video Clip Removed
46	21 Feb 2014	10:13:50 (-07:00)	[REDACTED], Fabian (Badge ID: [REDACTED]) Username: [REDACTED]	Evidence Record Accessed. Client IP Address: 173.226.125.243
47	21 Feb 2014	10:18:13 (-07:00)	[REDACTED] Fabian (Badge ID: [REDACTED]) Username: [REDACTED]	Evidence Record Streamed. Client IP Address: 173.226.125.243
48	21 Feb 2014	10:22:38 (-07:00)	[REDACTED], Fabian (Badge ID: [REDACTED]) Username: [REDACTED]	Evidence Record Accessed. Client IP Address: 173.226.125.243
49	21 Feb 2014	10:26:03 (-07:00)	[REDACTED] Fabian (Badge ID: [REDACTED]) Username: [REDACTED]	Video Clip Added: "Redaction Masks" (00:00:00 to 00:04:20)
50	21 Feb 2014	10:26:40 (-07:00)	[REDACTED] Fabian (Badge ID: [REDACTED]) Username: [REDACTED]	Video Clip Removed
51	21 Feb 2014	11:11:04 (-07:00)	[REDACTED] Fabian (Badge ID: [REDACTED]) Username: [REDACTED]	Evidence Record Accessed. Client IP Address: 173.226.125.243
52	21 Feb 2014	11:11:11 (-07:00)	[REDACTED], Fabian (Badge ID: [REDACTED]) Username: [REDACTED]	Evidence Record Streamed. Client IP Address: 173.226.125.243
53	21 Feb 2014	11:14:18 (-07:00)	[REDACTED] Fabian (Badge ID: [REDACTED]) Username: [REDACTED]	Video Clip Added: "Redaction Masks" (00:00:00 to 00:04:20)
54	21 Feb 2014	11:15:27 (-07:00)	[REDACTED], Fabian (Badge ID: [REDACTED]) Username: [REDACTED]	Video Clip Removed
55	04 Mar 2014	13:55:51 (-07:00)	[REDACTED] Fabian (Badge ID: [REDACTED]) Username: [REDACTED]	Evidence Record Accessed. Client IP Address: 173.226.125.243
56	04 Mar 2014	13:55:56 (-07:00)	[REDACTED], Fabian (Badge ID: [REDACTED]) Username: [REDACTED]	Evidence Record Streamed. Client IP Address: 173.226.125.243
57	13 Apr 2014	23:29:46 (-07:00)	[REDACTED] Fabian (Badge ID: [REDACTED]) Username: [REDACTED]	Evidence Record Accessed. Client IP Address: 83.110.18.159
58	15 Apr 2014	23:51:06 (-07:00)	Account, Temp (Badge ID: [REDACTED]) Username: [REDACTED]	Evidence Record Accessed. Client IP Address: 2.50.18.19
59	15 Apr 2014	23:51:17 (-07:00)	Account, Temp (Badge ID: [REDACTED]) Username: [REDACTED]	Evidence Record Streamed. Client IP Address: 2.50.18.19
60	15 Apr 2014	23:59:37 (-07:00)	Account, Temp (Badge ID: [REDACTED]) Username: [REDACTED]	Evidence Record Accessed. Client IP Address: 2.50.18.19
61	22 Apr 2014	08:00:00 (-07:00)	[REDACTED] Fabian (Badge ID: [REDACTED]) Username: [REDACTED]	Evidence Record Accessed. Client IP Address: 74.206.119.253
62	05 May 2014	10:57:41 (-07:00)	[REDACTED] Anthony (Badge ID: [REDACTED]) Username: [REDACTED]	Evidence Record Accessed. Client IP Address: 74.206.119.251
63	05 May 2014	10:58:26 (-07:00)	[REDACTED] Oussama (Badge ID: [REDACTED]) Username: [REDACTED]	Evidence Record Accessed. Client IP Address: 86.99.223.31
64	05 May 2014	10:58:45 (-07:00)	[REDACTED] Oussama (Badge ID: [REDACTED]) Username: [REDACTED]	Evidence Record Streamed. Client IP Address: 86.99.223.31
65	05 May 2014	11:01:21 (-07:00)	[REDACTED] Anthony (Badge ID: [REDACTED]) Username: [REDACTED]	Evidence Record Streamed. Client IP Address: 74.206.119.251

#	Date	Time	User	Activity
66	06 May 2014	05:20:14 (-07:00)	[REDACTED] Oussama (Badge ID: [REDACTED]) Username: [REDACTED]	Evidence Record Accessed. Client IP Address: 2.50.37.15
67	06 May 2014	05:20:22 (-07:00)	[REDACTED] Oussama (Badge ID: [REDACTED]) Username: [REDACTED]	Evidence Record Streamed. Client IP Address: 2.50.37.15
68	06 May 2014	05:28:26 (-07:00)	[REDACTED] Oussama (Badge ID: [REDACTED]) Username: [REDACTED]	Evidence Record Accessed. Client IP Address: 2.50.37.15
69	06 May 2014	05:30:56 (-07:00)	[REDACTED] Oussama (Badge ID: [REDACTED]) Username: [REDACTED]	Evidence Record Streamed. Client IP Address: 2.50.37.15
70	11 Jun 2014	20:57:34 (-07:00)	Account, Temp (Badge ID: [REDACTED]) Username: [REDACTED]	Evidence Record Accessed. Client IP Address: 71.211.111.61
71	11 Jun 2014	20:57:46 (-07:00)	Account, Temp (Badge ID: [REDACTED]) Username: [REDACTED]	Evidence Record Streamed. Client IP Address: 71.211.111.61
72	12 Jun 2014	14:55:38 (-07:00)	Account, Temp (Badge ID: [REDACTED]) Username: [REDACTED]	Evidence Record Accessed. Client IP Address: 173.226.125.243
73	12 Jun 2014	14:55:51 (-07:00)	Account, Temp (Badge ID: [REDACTED]) Username: [REDACTED]	Evidence Record Streamed. Client IP Address: 173.226.125.243
74	12 Jun 2014	14:56:58 (-07:00)	[REDACTED], Fabian (Badge ID: [REDACTED]) Username: [REDACTED]	Evidence Record Accessed. Client IP Address: 173.226.125.243
75	12 Jun 2014	14:57:17 (-07:00)	[REDACTED], Fabian (Badge ID: [REDACTED]) Username: [REDACTED]	Evidence Record Streamed. Client IP Address: 173.226.125.243
76	09 Jul 2014	09:38:12 (-07:00)	account, temp (Badge ID: [REDACTED]) Username: [REDACTED]	Evidence Record Accessed. Client IP Address: 172.56.5.220
77	09 Jul 2014	09:38:30 (-07:00)	account, temp (Badge ID: [REDACTED]) Username: [REDACTED]	Evidence Record Streamed. Client IP Address: 172.56.5.220
78	10 Jul 2014	07:02:39 (-07:00)	Account, Temp (Badge ID: [REDACTED]) Username: [REDACTED]	Evidence Record Accessed. Client IP Address: 75.141.57.228
79	10 Jul 2014	07:02:58 (-07:00)	Account, Temp (Badge ID: [REDACTED]) Username: [REDACTED]	Evidence Record Streamed. Client IP Address: 75.141.57.228
80	10 Jul 2014	07:05:06 (-07:00)	Account, Temp (Badge ID: [REDACTED]) Username: [REDACTED]	Evidence Record Accessed. Client IP Address: 75.141.57.228
81	10 Jul 2014	07:09:28 (-07:00)	account, temp (Badge ID: [REDACTED]) Username: [REDACTED]	Evidence Record Accessed. Client IP Address: 208.54.44.198
82	10 Jul 2014	07:09:43 (-07:00)	account, temp (Badge ID: [REDACTED]) Username: [REDACTED]	Evidence Record Streamed. Client IP Address: 208.54.44.198
83	10 Jul 2014	07:22:32 (-07:00)	account, temp (Badge ID: [REDACTED]) Username: [REDACTED]	Evidence Record Accessed. Client IP Address: 208.54.44.198
84	14 Jul 2014	09:21:45 (-07:00)	Account, Temp (Badge ID: [REDACTED]) Username: [REDACTED]	Evidence Record Accessed. Client IP Address: 64.129.145.82
85	14 Jul 2014	09:21:51 (-07:00)	Account, Temp (Badge ID: [REDACTED]) Username: [REDACTED]	Evidence Record Streamed. Client IP Address: 64.129.145.82
86	15 Jul 2014	09:53:02 (-07:00)	[REDACTED] Fabian (Badge ID: [REDACTED]) Username: [REDACTED]	Evidence Record Accessed. Client IP Address: 50.84.226.194
87	15 Jul 2014	09:53:12 (-07:00)	[REDACTED] Fabian (Badge ID: [REDACTED]) Username: [REDACTED]	Evidence Record Streamed. Client IP Address: 50.84.226.194
88	15 Jul 2014	12:48:58 (-07:00)	Account, Temp (Badge ID: [REDACTED]) Username: [REDACTED]	Evidence Record Added to Case 'd782-d'
89	15 Jul 2014	13:38:36 (-07:00)	Account, Temp (Badge ID: [REDACTED]) Username: [REDACTED]	Evidence Record Accessed. Client IP Address: 50.84.226.194
90	15 Jul 2014	13:38:44 (-07:00)	Account, Temp (Badge ID: [REDACTED]) Username: [REDACTED]	Evidence Record Streamed. Client IP Address: 50.84.226.194
91	15 Jul 2014	13:41:02 (-07:00)	Account, Temp (Badge ID: [REDACTED]) Username: [REDACTED]	Video Clip Added: "Redaction Masks" (00:00:00 to 00:04:20)
92	15 Jul 2014	14:34:44 (-07:00)	[REDACTED], Fabian (Badge ID: [REDACTED]) Username: [REDACTED]	Evidence Record Accessed. Client IP Address: 50.84.226.194

#	Date	Time	User	Activity
93	15 Jul 2014	14:34:56 (-07:00)	[REDACTED], Fabian (Badge ID: [REDACTED]) Username: [REDACTED]	Evidence Record Downloaded. Internal Record ID: FILE:8F6696533A9E4E82A0D224509D0E55BA@54716D8A AFBB4F1D8D69DC602BD6B53C Client IP Address: 50.84.226.194
94	29 Aug 2014	11:14:33 (-07:00)	[REDACTED], Fabian (Badge ID: [REDACTED]) Username: [REDACTED]	Evidence Record Accessed. Client IP Address: 74.206.119.250
95	29 Aug 2014	11:15:34 (-07:00)	[REDACTED], Fabian (Badge ID: [REDACTED]) Username: [REDACTED]	Evidence Record Accessed. Client IP Address: 74.206.119.250
96	29 Aug 2014	11:22:13 (-07:00)	[REDACTED], Fabian (Badge ID: [REDACTED]) Username: [REDACTED]	Evidence Record Accessed. Client IP Address: 74.206.119.250
97	29 Aug 2014	12:31:38 (-07:00)	[REDACTED], Fabian (Badge ID: [REDACTED]) Username: [REDACTED]	Evidence Record Accessed. Client IP Address: 74.206.119.250
98	29 Aug 2014	12:32:43 (-07:00)	[REDACTED], Fabian (Badge ID: [REDACTED]) Username: [REDACTED]	Shared with [REDACTED]@yahoo.com. Share expires on 28 Sep 2014 12:32:42 (-07:00)
99	06 Oct 2014	12:45:54 (-07:00)	[REDACTED], Fabian (Badge ID: [REDACTED]) Username: [REDACTED]	Evidence Record Accessed. Client IP Address: 74.206.119.246

DEMC

EVIDENCE.COM

Scottsdale, AZ, US

Document generated: 06 Oct 2014 - 12:59:52 -07:00 by Marrero, Fabian(UwypwGk)

EVIDENCE AUDIT TRAIL

Evidence		Source	
Case ID		Device Type	Taser X26P
Categories	Training Demo	Device Name	ZZX1200D2
Title	TASER X26P Device Log	Serial Number	ZZX1200D2
		Other	SYNC
Recorded	19 May 2013 13:54:11		
Uploaded	19 May 2013 13:54:11	Usage	
Uploader	[Redacted], Fabian (Badge ID: [Redacted])		
Evidence ID	83B6F5871BAF4BCC8D9FD7C1F7FE889B	Page views	2
		File downloads	
		Video playbacks	
		Last Viewed Or Downloaded On	06 Oct 2014 12:59:51

#	Date	Time	User	Activity
1	19 May 2013	13:54:11 (-07:00)	System	Evidence Record Created
2	19 May 2013	13:54:12 (-07:00)	System	Evidence Upload Completed Successfully.
3	19 May 2013	13:54:12 (-07:00)	System	Evidence Upload Completed Successfully.
4	19 May 2013	13:54:13 (-07:00)	System	Evidence Upload Completed Successfully.
5	19 May 2013	13:54:14 (-07:00)	[Redacted] Fabian (Badge ID: [Redacted]) Username: FMarrero	Evidence Record Accessed. Client IP Address: 74.206.119.254
6	19 May 2013	14:06:44 (-07:00)	[Redacted] Fabian (Badge ID: [Redacted]) Username: FMarrero	Reassigned to ECom, Admin (Badge ID: 00000)
7	19 May 2013	14:06:57 (-07:00)	[Redacted] Fabian (Badge ID: [Redacted]) Username: FMarrero	Reassigned to Account, Temp (Badge ID: 0001)
8	19 May 2013	14:07:12 (-07:00)	[Redacted] Fabian (Badge ID: [Redacted]) Username: FMarrero	Reassigned to ECom, Admin (Badge ID: 00000)
9	11 Jul 2013	15:52:03 (-07:00)	Account, Temp (Badge ID: [Redacted]) Username: [Redacted]	Category 'Training Demo' Added
10	11 Jul 2013	15:58:52 (-07:00)	Account, Temp (Badge ID: [Redacted]) Username: [Redacted]	Reassigned to account, temp (Badge ID: 0008)
11	06 Oct 2014	12:59:14 (-07:00)	[Redacted] Fabian (Badge ID: [Redacted]) Username: [Redacted]	Evidence Record Accessed. Client IP Address: 74.206.119.246

[REDACTED], Fabian

Badge: [REDACTED]

Document generated: 06 Oct 2014 - 12:58:31 -07:00 by [REDACTED], Fabian ([REDACTED])

EVIDENCE.COM

Associated
IPs

- 74.206.119.246
- 66.194.242.246
- 208.54.70.184
- 74.206.119.253
- 173.226.125.243
- 74.206.119.250
- 50.84.226.194
- 64.129.145.82
- 74.206.119.248
- 208.54.44.198

Keeps track of
the 10 most
recent IP
addresses

USER AUDIT TRAIL

#	Date	Time	Activity
1	06 Oct 2014	12:43:41 (-07:00)	Successful Login
2	06 Oct 2014	10:43:46 (-07:00)	Successful Login
3	06 Oct 2014	10:43:36 (-07:00)	Failed Login
4	06 Oct 2014	09:37:06 (-07:00)	Successful Login
5	02 Oct 2014	15:47:11 (-07:00)	Successful Login
6	02 Oct 2014	06:22:52 (-07:00)	Password Reset
7	28 Sep 2014	14:48:01 (-07:00)	Successful Login
8	23 Sep 2014	15:38:11 (-07:00)	Successful Login
9	23 Sep 2014	15:35:11 (-07:00)	Successful Login
10	23 Sep 2014	15:35:06 (-07:00)	Failed Login
11	23 Sep 2014	15:32:07 (-07:00)	Successful Login
12	22 Sep 2014	14:27:20 (-07:00)	Successful Login
13	22 Sep 2014	14:02:35 (-07:00)	Successful Login
14	19 Sep 2014	16:03:10 (-07:00)	Successful Login
15	19 Sep 2014	15:39:17 (-07:00)	Failed Login
16	12 Sep 2014	16:22:39 (-07:00)	Successful Login
17	12 Sep 2014	16:22:33 (-07:00)	Failed Login
18	12 Sep 2014	16:18:32 (-07:00)	Successful Login
19	12 Sep 2014	16:07:58 (-07:00)	Successful Login
20	09 Sep 2014	15:18:58 (-07:00)	Failed Login
21	09 Sep 2014	15:18:52 (-07:00)	Failed Login
22	09 Sep 2014	15:18:50 (-07:00)	Failed Login
23	09 Sep 2014	15:16:34 (-07:00)	Failed Login
24	08 Sep 2014	10:47:32 (-07:00)	Failed Login
25	08 Sep 2014	10:46:56 (-07:00)	Failed Login
26	08 Sep 2014	10:45:27 (-07:00)	Successful Login
27	05 Sep 2014	12:54:35 (-07:00)	Failed Login
28	03 Sep 2014	16:40:36 (-07:00)	Successful Login
29	03 Sep 2014	16:40:32 (-07:00)	Failed Login
30	03 Sep 2014	16:40:32 (-07:00)	Failed Login

#	Date	Time	Activity
31	03 Sep 2014	16:37:40 (-07:00)	Successful Login
32	02 Sep 2014	10:02:30 (-07:00)	Successful Login
33	29 Aug 2014	12:45:25 (-07:00)	Successful Login
34	29 Aug 2014	12:28:45 (-07:00)	Successful Login
35	29 Aug 2014	12:28:37 (-07:00)	Failed Login
36	29 Aug 2014	11:18:05 (-07:00)	Role assignments changed
37	29 Aug 2014	11:15:17 (-07:00)	Successful Login
38	29 Aug 2014	10:58:14 (-07:00)	Successful Login
39	29 Aug 2014	10:58:03 (-07:00)	Failed Login
40	29 Aug 2014	10:52:03 (-07:00)	Successful Login
41	29 Aug 2014	10:51:49 (-07:00)	Password Reset
42	29 Aug 2014	10:51:08 (-07:00)	Failed Login
43	28 Aug 2014	14:18:02 (-07:00)	Failed Login
44	20 Aug 2014	09:00:15 (-07:00)	Failed Login
45	13 Aug 2014	10:54:32 (-07:00)	Successful Login
46	13 Aug 2014	10:54:14 (-07:00)	Password Reset
47	13 Aug 2014	10:52:51 (-07:00)	Failed Login
48	13 Aug 2014	10:52:43 (-07:00)	Failed Login
49	12 Aug 2014	09:38:53 (-07:00)	Failed Login
50	12 Aug 2014	09:38:48 (-07:00)	Failed Login
51	12 Aug 2014	09:38:45 (-07:00)	Failed Login
52	11 Aug 2014	16:00:18 (-07:00)	Failed Login
53	08 Aug 2014	15:16:22 (-07:00)	Successful Login
54	08 Aug 2014	15:16:10 (-07:00)	Password Reset
55	08 Aug 2014	15:15:05 (-07:00)	Failed Login
56	08 Aug 2014	15:14:47 (-07:00)	Failed Login
57	08 Aug 2014	13:52:05 (-07:00)	Successful Login
58	08 Aug 2014	13:51:57 (-07:00)	Failed Login
59	08 Aug 2014	13:51:49 (-07:00)	Failed Login
60	05 Aug 2014	15:02:20 (-07:00)	Successful Login
61	05 Aug 2014	10:35:34 (-07:00)	Successful Login
62	23 Jul 2014	16:30:25 (-07:00)	Successful Login
63	23 Jul 2014	16:30:22 (-07:00)	Failed Login
64	15 Jul 2014	14:34:39 (-07:00)	Successful Login
65	15 Jul 2014	14:34:24 (-07:00)	Failed Login
66	15 Jul 2014	11:51:26 (-07:00)	Successful Login
67	15 Jul 2014	09:31:26 (-07:00)	Successful Login
68	15 Jul 2014	09:30:46 (-07:00)	Failed Login
69	15 Jul 2014	09:30:22 (-07:00)	Failed Login

TASSEER

Q2 2014

FORWARD-LOOKING STATEMENTS

This presentation contains forward-looking statements within the meaning of Section 27A of the Securities Act of 1933, as amended (the "Securities Act"), and Section 21E of the Securities Exchange Act of 1934, as amended (the "Exchange Act"), including statements, without limitation, regarding our expectations, beliefs, intentions or strategies regarding the future. We intend that such forward-looking statements be subject to the safe-harbor provided by the Private Securities Litigation Reform Act of 1995. The forward-looking information is based upon current information and expectations regarding TASER International, Inc. These estimates and statements speak only as of the date on which they are made, are not guarantees of future performance, and involve certain risks, uncertainties and assumptions that are difficult to predict. Such forward-looking statements relate to: expected revenue and earnings growth; estimations regarding the size of our target markets; successful penetration of the law enforcement market; expansion of product sales to the private security, military and consumer self-defense markets; growth expectations for new and existing products and accounts; expansion of production capability; new product introductions; product safety and our business model. We caution that these statements are qualified by important factors that could cause actual results to differ materially from those reflected by the forward-looking statements herein.

OUR INVESTMENT DRIVERS



MULTI-BILLION

AXON-Evidence.com:
Entry into Multi-Billion
Dollar Annual Law
Enforcement IT Industry¹

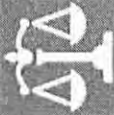

NO DEBT

Strong Balance Sheet:
No Debt other than
Capital Leases (\$100k)



UPGRADE OPP

Significant Weapons
Upgrade Opportunity



WHITE SPACE

Largely Untapped
International Markets



TRUSTED

Strong IP, Brand &
Customer
Relationships



\$120M BUYBACK

\$120 million in
stock buybacks
executed

OUR SOLUTION

FOR THE VIDEO MARKET

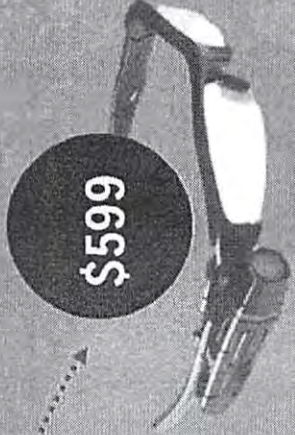

\$599

AXON FLEX

- Premium customer
- Point of View perspective
- Multiple mounting options
- Full work shift battery
- Constant streaming

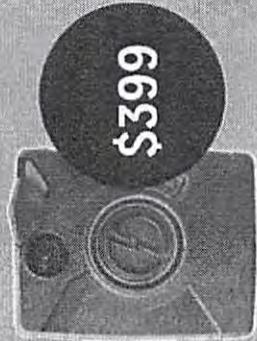

\$399

AXON BODY

- For the convenience driven and price sensitive customer
- On-officer view point
- Full work shift battery
- Constant streaming



ROADMAP

Video Segment

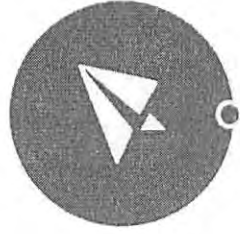
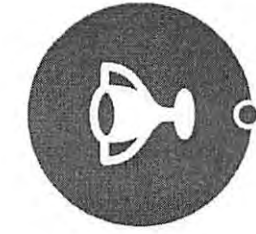
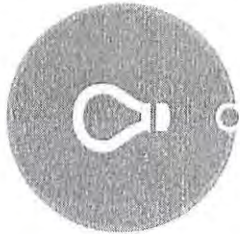

STRATEGY

- Focused on software and services to drive long term value creation
- Profitability in cameras is secondary

GOALS

- Accelerate market adoption/acceptance of technology
- Avoid fragmentation

ACTIONS

- Disruptive pricing model with new AXON body
- EVIDENCE.com offering that is unparalleled
- Provide workflow, including around the ingest of video, that is market-leading



TRUSTED CLOUD PARTNER

Federal Government and CIA Have Paved The Way To Lessen
Cloud Data Security Concerns In Municipalities

CIA rewarded
600 MILLION
data center contract to
Amazon Web Services





AXON FLEX STUDY

Rialto PD / Cambridge University



REDUCTION

In citizen complaints

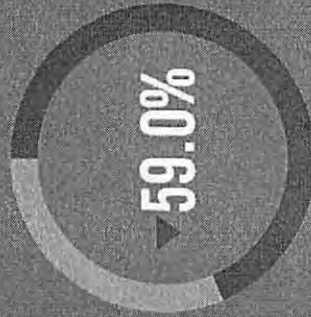

REDUCTION

In use of force

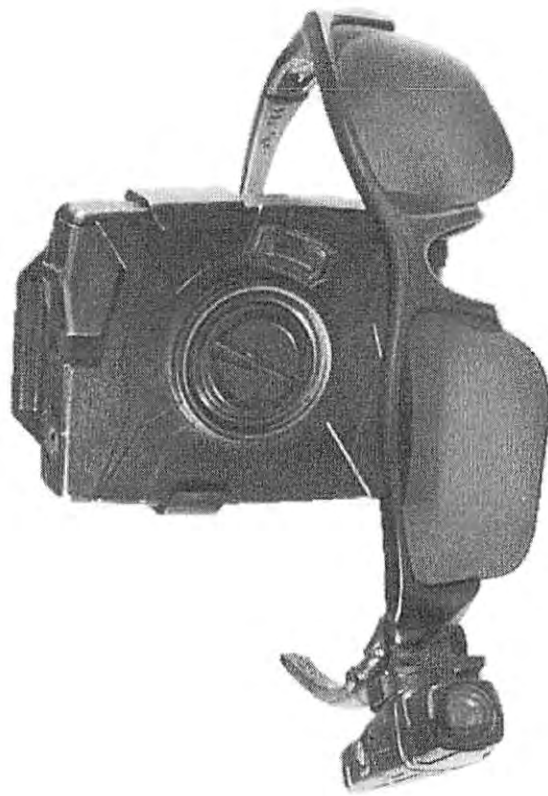

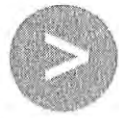

COMPLIANCE COST AVOIDANCE

City of Rialto Analysis

\$20,000	-----◆	Cost/customer
X 21	-----◆	# of Complaints Avoided with Cameras
<hr/>	-----◆	Year 1 Cost Savings
\$420,000		

- \$90,000	-----◆	Cost of Cameras and Evidence.com
<hr/>	-----◆	Net Savings Year 1
\$330,000		



CITY SAVED \$4

FOR EACH \$1 SPENT



EVIDENCE.COM

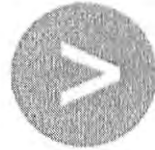

EVIDENCE.COM

A Public Safety Platform

E.COMFILE UPLOADS

Exponential Growth

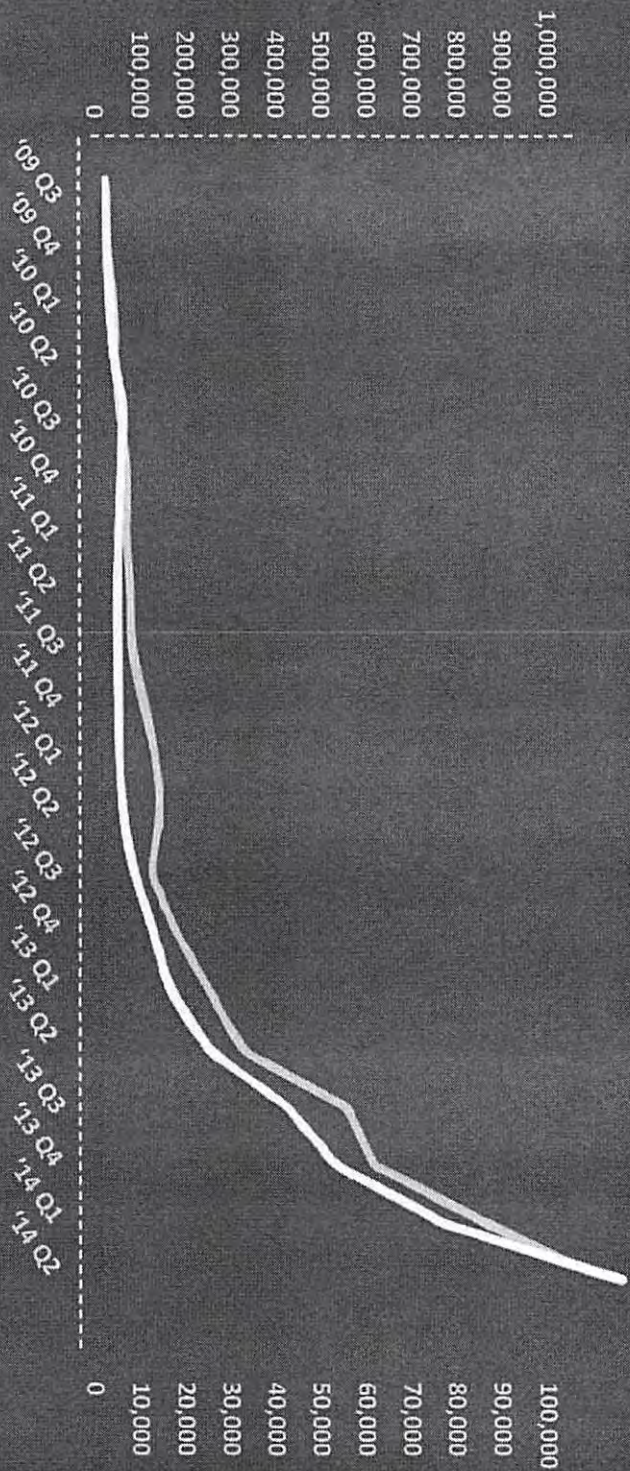

Files

KEY

GBS



OUR MOMENTUM

For AXON and EVIDENCE.com Bookings





VIDEO ORDER

A multiple of traditional weapon order

Hypothetical

Weapons order	\$1,200,000	Initial Order – Handles, Batteries, Warranty, Holster
1,000 x26p units	+ \$230,000	Add-on Orders of Training Cartridges
	+ \$67,000	Add-on Orders of Field-use Cartridges
	<u>\$1,497,000</u>	Total Opportunity over 5 years

Video order	\$3,950,000	Video Order with 5 year Evidence.com Contract
VS		
Weapons order	<u>/\$1,497,000</u>	Weapons 5 year opportunity
	2.63	Video 5 Year Value Multiple

OUR DEFERRED REVENUE GROWTH

EVIDENCE.COM

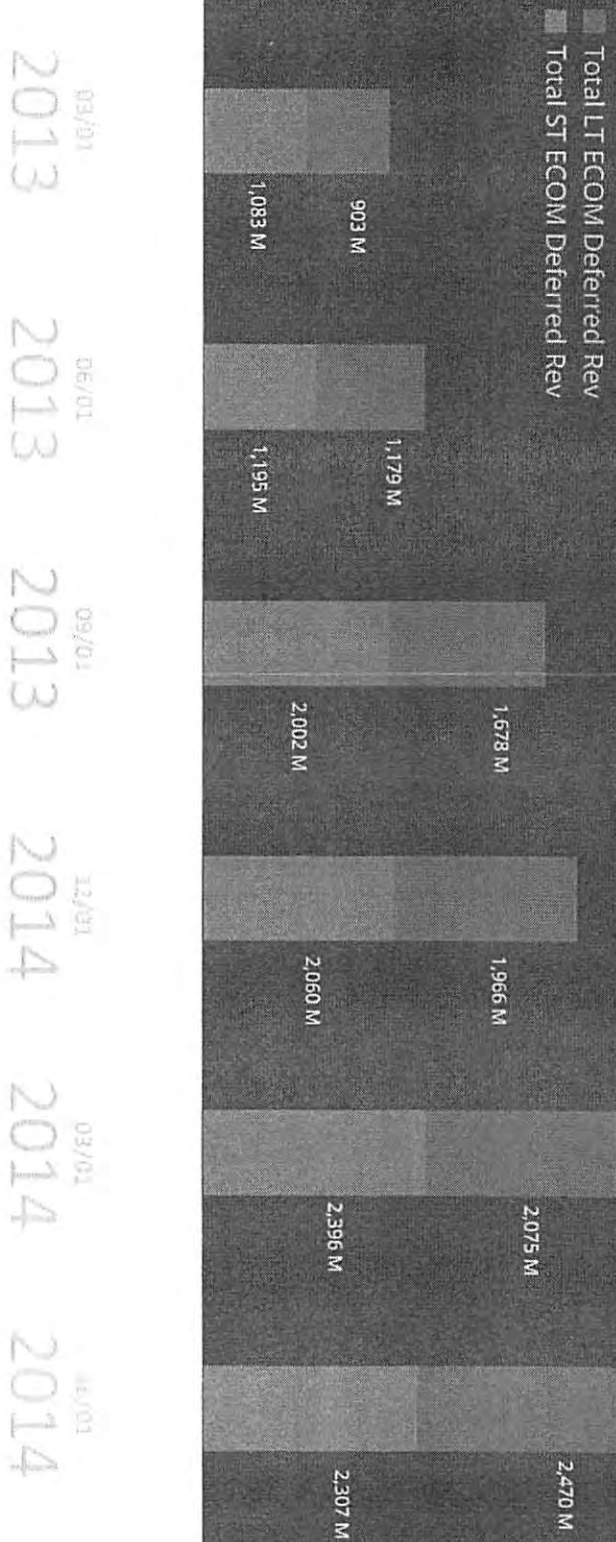



V

TASER X2

Every Officer Needs Backup

- Introduced in April 2011
- Immediate Backup Shot
- Dual Lasers
- High Performance & Reliability
- Displays warning arc while loaded
- Compact Full Time Carry



V

TASER X26P

An upgraded classic.

- Introduced in January 2013
- Reduced training risk
- All Digital Platform
- High Performance & Reliability
- Current and Charge Metering
- Compact Full Time Carry



INTERNATIONAL SALES STRATEGY

Keep what's working



■ Headquarters
● Missionary Team

eCommerce



Local Master Instructor Board



Engage MD's



Chief Courses in Country



Plan + Forecast



Study/Engage Influencers



OUR SYNERGIES BETWEEN SEGMENTS

TRUSTED

TASER is already a trusted partner within law enforcement

STAFFED

Sales staff for video and weapons share and develop leads

CONNECTED

TASER already has the relationships with all levels of command staff at more than 17,000 out of the 18,000 agencies in the U.S. today.

INVESTED

Weapons segment produces steady cash flow which allows investments in emerging technologies

DIVERSIFIED

Video products and SaaS solution gives TASER the ability to double sales over time by having a second product line.



OUR BOARD DIVERSITY

FINANCIAL LITERACY



GOV'T OR POLITICAL



MEDICAL OR SCIENTIFIC



LAW ENFORCEMENT OR MILITARY



EMERGING TECHNOLOGY



RISK OVERSIGHT



DR. RICHARD
CARMONA

JUDY
MARTZ

BRET
TAYLOR

MICHAEL
GARNREITER

HADI
PARTOVI

DR. MARK
KROLL

LT. JOHN
CALDWELL

**BRET
TAYLOR**



CEO of
Quip



EX-CTO of
Facebook



Co-creator of
Google Maps

**HADI
PARTOVI**



Co-founder
Code.org



Angel
Investor



Product
Manager

V

New Technology Focused Board Members

OUR INVESTMENT DRIVERS



MULTI-BILLION

AXON-Evidence.com:
Entry into Multi-Billion
Dollar Annual Law
Enforcement IT Industry¹



NO DEBT

Strong Balance Sheet:
No Debt other than
Capital Leases (\$100k)



UPGRADE OPP

Significant Weapons
Upgrade Opportunity



WHITE SPACE

Largely Untapped
International Markets



TRUSTED

Strong IP, Brand &
Customer
Relationships



\$120M BUYBACK

\$120 million in
stock buybacks
executed

4. RFP #151089

CITY OF TUCSON REQUEST FOR PROPOSAL

REQUEST FOR PROPOSAL NUMBER: 151089
PROPOSAL DUE DATE: OCTOBER 20, 2014 AT 4:00 P.M. LOCAL AZ TIME
PROPOSAL SUBMITTAL LOCATION: Department of Procurement
 255 W. Alameda, 6th Floor, Tucson, AZ 85701
MATERIAL OR SERVICE: BODY WORN CAMERAS AND STORAGE SYSTEM
PRE-PROPOSAL CONFERENCE DATE: OCTOBER 3, 2014
TIME: 9:00 A.M., LOCAL AZ TIME
LOCATION: CITY HALL, PROCUREMENT CONFERENCE RM,
 255 W. ALAMEDA, 6TH FL, TUCSON, AZ
CONTRACT OFFICER: GILLIAN B. NEEDHAM
TELEPHONE NUMBER: (520) 837-4132
 GILLIAN.NEEDHAM@tucsonaz.gov

A copy of this solicitation and possible future amendments may be obtained from our Internet site at: <http://www.tucsonprocurement.com/> by selecting the Bid Opportunities link and the associated solicitation number. The City does not mail out Notices of available solicitations via the U.S. Postal Service. Email notifications are sent to those interested offerors who are registered with us and who have selected email as their preferred delivery method. To register, please visit www.tucsonprocurement.com, click on Vendors, then click on Vendor Registration. To update an existing record, click on Vendors, click on What's New?, and read the section titled "Notice of Solicitations." You may also call (520) 791-4217 if you have questions.

Competitive sealed proposals for the specified material or service shall be received by the Department of Procurement, 255 W. Alameda, 6th Floor, Tucson, Arizona 85701, until the date and time cited. Proposals must be in the actual possession of the Department of Procurement at the location indicated, on or prior to the exact date and time indicated above. Late proposals shall not be considered. The prevailing clock shall be the City Department of Procurement clock.

Proposals must be submitted in a sealed envelope. The Request for Proposal number and the offeror's name and address should be clearly indicated on the outside of the envelope. All proposals must be completed in ink or typewritten. Questions must be addressed to the Contract Officer listed above.

*****ALERT*****

The City of Tucson has implemented additional security procedures in City Hall. All visitors will be required to enter only through the north side doors facing Alameda Street. When attending a meeting or delivering a solicitation response to City Hall, please allow ample time to go through the security screening process.

Visitors will be required to do the following:

- Pass through metal detectors / security wands;
- Purses and bags will be searched by security personnel;
- Obtain a visitor's pass.

GN/cq

INTRODUCTION

The Tucson Police Department is a large agency of approximately 950 sworn officers serving a diverse community of over 600,000. The department has a history of progressive thinking and adapting to the ever changing law enforcement environment. As technology evolves, the department is faced with challenges not previously seen in the world of policing. The Tucson Police Department must take advantage of proven technology in the fast growing market of body worn cameras to better serve our community.

The City of Tucson intends to purchase **Officer Worn Cameras** for several divisions who have a high level of daily interaction with the public. The intention of the Police Department is to make multiple purchases as funding becomes available. The Police department is open to any placement of the camera, method of recording and evidence storage.

SCOPE OF WORK

A. GENERAL REQUIREMENTS

1. **CURRENT PRODUCTS:** All products being offered in response to this solicitation shall be in current and ongoing production, shall be formally announced for general marketing purposes, shall be a model or type currently functioning in a user environment and capable of meeting or exceeding all specifications and requirements set forth in this solicitation.
2. **DEFECTIVE PRODUCT:** All defective products shall be replaced and exchanged by the Contractor. The cost of transportation, unpacking, inspection, re-packing, re-shipping or other like expenses shall be paid by the Contractor. All replacement products must be received by the City within seven (7) days of initial notification.
3. **DESCRIPTIVE LITERATURE:** All offers must include complete manufacturers' descriptive literature regarding the product they propose to furnish. Literature shall have sufficient detail in order to allow a complete evaluation of the offer submitted.
4. **EQUIPMENT AND RECALL NOTICES:** In the event of any recall notice, technical service bulletin, or other important notification affecting equipment purchased from this contract, a notice shall be sent to the Contractor Representative(s). It shall be the responsibility of the contractors to ensure that all recall notices are sent directly.
5. **KEY PERSONNEL:** It is essential that the Contractor provide adequate experienced personnel, capable of and devoted to the successful accomplishment of work to be performed under this Contract. The Contractor must agree to assign specific individuals to the key positions. The Contractor agrees that, once assigned to work under this Contract, key personnel shall not be removed or replaced without written notice to and subsequent concurrence by the City. If key personnel are not available for work under this Contract for a continuous period exceeding thirty calendar days, or are expected to devote substantially less effort to the work than initially anticipated, the Contractor shall immediately notify the City, and shall, subject to the concurrence of the City, replace such personnel with personnel of substantially equal ability and qualifications.
6. **SAMPLES AND DEMONSTRATIONS:** Product demonstrations will be conducted as part of the evaluation process. Offerors who are invited to participate in a product demonstration will be required to provide 5 units to the City within 7 days of notification for testing purposes. Product will be tested for approximately 3 weeks. Samples shall be an exact and true representative sample of the actual product offered. Each sample shall be properly tagged or labeled with the name of the Offeror and manufacturer, the due date, and the solicitation number. Samples shall be provided at no additional costs to the City. Samples will be returned to the Offeror.
7. **WARRANTY:** Offeror shall warrant that all equipment and parts furnished in their bid/offer are newly manufactured and free from defects in material and workmanship for no less than one (1) year from the date the equipment is delivered or installed. Warranty shall also guarantee accepted trade standards of quality, fitness for the intended uses, and conformance to promises or specified specifications. No other express or implied warranty shall eliminate the vendor's liability as stated herein.

B. TRAINING

1. The Contractor shall provide the City with primary training for each basic unit of equipment purchased. This training shall be adequate to equip a typical equipment operator in order to ensure proper operation and utilization of the equipment supplied. Any manuals necessary to perform the required training shall be furnished by the Contractor.
2. The Contractor shall provide a "train-the-trainer" program for the operation and use of the equipment
3. The Contractor shall provide training for technical staff for maintenance, troubleshooting and changing of components in need of repair.

C. REPORTING

In Appendix A, Offeror shall provide examples of all standard reports:
Offeror's proposed system shall have the following reporting abilities:

1. Ability to produce comprehensive management reporting for all areas within the organizational process.
Comply: Yes No Exception: _____
2. Ability to produce both standard and ad hoc reports.
Comply: Yes No Exception: _____
3. Ability to allow for the use of standard statistical packages so that research and analysis can take place.
Comply: Yes No Exception: _____
4. Ability to design and implement both on-line ad hoc queries and batch reporting programs as required by user.
Comply: Yes No Exception: _____
5. Ability for report generator to allow user to select data, choose fields, and create calculated fields.
Comply: Yes No Exception: _____
6. Ability to extract data to another tool, such as EXCEL or a report writer.
Comply: Yes No Exception: _____

D. FUNCTIONAL HARDWARE REQUIREMENTS

Offeror's proposed hardware shall offer the following features:

1. Provision of a lightweight unit that must not interfere with normal police operations.
Comply: Yes No Exception: _____
2. Ability to detach camera to maximize the actual view seen by the user.
Comply: Yes No Exception: _____

3. Ability to capture audio from multiple parties of a conversation or sound/speech from a reasonable distance, not just that of the user.

Comply: Yes No Exception: _____

4. Ability to produce a recording that reflects what the officer was seeing and hearing during the event.

Comply: Yes No Exception: _____

5. Ability to provide hardware that must be user-friendly with simple activation.

Comply: Yes No Exception: _____

6. Ability to access the record button by officers wearing gloves while preventing unwanted activation.

Comply: Yes No Exception: _____

7. Ability for an illuminated record indicator on the unit visible to the user.

Comply: Yes No Exception: _____

8. Ability to disable the illuminated record indicator on the unit.

Comply: Yes No Exception: _____

9. Ability for pre event recording capability with the option to disable it.

Comply: Yes No Exception: _____

10. Ability for a privacy mode (complete off) that prevents pre-event recording.

Comply: Yes No Exception: _____

11. Ability for a rechargeable battery that is end-user replaceable.

Comply: Yes No Exception: _____

12. Ability for the battery to last through a working shift of at least 12 hours. *The AXON flex battery is rechargeable but not field replaceable unless camera or controller is replaced*

Comply: Yes No Exception: _____

13. Ability for an internal digital storage that can accommodate multiple video recordings with the capacity to hold data for one work shift of at least 12 hours.

Comply: Yes No Exception: _____

14. Ability to maintain consistent audio/visual recording quality while subject to interference from the following sources:

- High powered radio frequency transmissions
- Other radio frequency interference (including UHF, VHF, an HF transmitters)
- Automobile alternator, ignition, and electrical systems
- Fan motors from automobile heaters and air conditioners
- Other patrol vehicle electrical systems to include radios, emergency lights, sirens, mobile data computers, and speed measuring devices
- High voltage power line, traffic signals, neon signs, etc.

Comply: Yes No Exception: *One inch minimum separation should be maintained between the camera and the source of interference.*

15. Ability for a unit that does not generate electromagnetic interference or radiation that interferes with communications of other electronic equipment used by officers.

Comply: Yes No Exception: _____

16. Ability to operate within the range of temperatures from 0-120 degrees Fahrenheit while being exposed to humidity.

Comply: Yes No Exception: _____

17. Ability to provide a camera and lens that is equipped with auto focus, automatic exposure, and automatic white balance.

Comply: Yes No Exception: _____

18. Ability to adjust auto focus, automatic exposure, and automatic white balance at an administrative level.

Comply: Yes No Exception: _____

19. Ability to provide a camera with a minimum field of view of 40 degrees.

Comply: Yes No Exception: _____

E. SOFTWARE TECHNICAL REQUIREMENTS

1. Camera must be compatible with Win7 and Win8, including IE8 and above *which paired with a mobile device and Evidence Sync, a free app*

Comply: Yes No Exception: _____

2. All required applications must be available for 32-bit or 64-bit operating systems.

Comply: Yes No Exception: _____

3. Ability to provide a warning message when the Hard Disk Drive (HDD) fills to 95% of its capacity. If the HDD is full, then the system should stop accepting new data.

Comply: Yes No Exception: _____

4. Ability to upgrade firmware/software that should be straightforward and should not require any connection to the internet.

F. PORTAL CAPABILITY
Comply: Yes No Exception: *Evidence.com is a cloud based storage system and must be connected to the internet to receive updates to firmware and software*

1. Provide single sign-on to the total system, and all its component parts based on person's role.

Comply: Yes No Exception: _____

2. Ability to customize which objects are displayed on the portal entry.

Comply: Yes No Exception: _____

3. Ability to add other applications to this portal.
- Comply: Yes No Exception: _____
- With integration for sales rep can work with the city/agency to determine needs and potential additional costs*

G. VIDEO

1. Ability to ensure that the evidence is appropriate for use in court. It is desirable that the unit should record and play video and audio data in the same format – without any loss of data through compression and replay options.

2. Ability to meet Federal and State and local laws that reference disclosure requirements. It is also desirable that the video/audio record and replay format is a common 'industry standard' format that will be available to the vast majority of defense solicitors through universally available, computer software.
- Comply: Yes No Exception: _____

3. Ability to provide a system that consists of a recording device linked to a camera and microphone. It will be capable of being operated by one person and will be worn in such a way as to allow the user to retain full mobility and to keep both hands free. It is intended as an overt recording system and full or partial concealment is not required.

4. Ability to record in a non-proprietary, standard file format to enable replay on domestic DVD players and computers (PCs and Macs) without conversion. The recording device should not permit the editing or deletion of recordings.
- Comply: Yes No Exception: _____

5. Ability for each recorder to have a unique serial number.
- Comply: Yes No Exception: _____

H. IMAGE QUALITY

1. Ability to record 30 frames per second.
- Comply: Yes No Exception: _____
2. Ability to record at a minimum of VGA (1024 x 768) resolution.
- Comply: Yes No Exception: _____
3. Ability to provide quality recording, such that an individual should be recognizable up to a distance of 7m from the camera.
- Comply: Yes No Exception: _____

INSTRUCTIONS TO OFFERORS

1. **DEFINITION OF KEY WORDS USED IN THE SOLICITATION:**
For purposes of this solicitation and subsequent contract, the following definitions shall apply:

City: The City of Tucson, Arizona
Contract: The legal agreement executed between the City and the Contractor/Consultant. The Contract shall include this RFP document incorporated herein by reference, all terms, conditions, specifications, scope of work, Amendments, the Contractor's offer and negotiated items as accepted by the City.
Contractor/Consultant: The individual, partnership, or corporation who, as a result of the competitive solicitation process, is awarded a contract by the City.
Contract Representative: The City employee or employees who have specifically been designated to act as a contact person or persons to the Contractor, and is responsible for monitoring and overseeing the Contractor's performance under this Contract.
Director of Procurement: The contracting authority for the City, authorized to sign contracts and amendments hereto on behalf of the City.
May: Indicates something that is not mandatory but permissible.
Offeror: The individual, partnership, or corporation who submits a proposal in response to a solicitation.
Shall, Will, Must: Indicates a mandatory requirement. Failure to meet these mandatory requirements, if they constitute a substantive requirement, may, at the City's sole discretion, result in the rejection of a proposal as non-responsive.
Should: Indicates something that is recommended but not mandatory. If the Offeror fails to provide recommended information, the City may, at its sole option, ask the Offeror to provide the information or evaluate the proposal without the information.

2. **PRE-PROPOSAL CONFERENCE:** If scheduled, the date and time of a Pre-Proposal conference is indicated on the cover page of this document. Attendance at this conference is not mandatory. Written minutes and/or notes will not be available, therefore attendance is encouraged. If an Offeror is unable to attend the Pre-Proposal Conference questions may be submitted in writing. Offerors are encouraged to submit written questions, via electronic mail or facsimile, at least five days prior to the Request for Proposal due date to the Contract Officer listed above. The purpose of this conference will be to clarify the contents of this Request for Proposal in order to prevent any misunderstanding of the City's position. Any doubt as to the requirements of this Request for Proposal or any apparent omission or discrepancy should be presented to the City at this conference. The City will then determine the appropriate action necessary, if any, and may issue a written amendment to the Request for Proposal. Oral statements or instructions will not constitute an amendment to this Request for Proposal.

3. **INQUIRIES:** Any question related to the Request for Proposal shall be directed to the Contract Officer whose name appears above. An offeror shall not contact or ask questions of the department for whom the requirement is being procured. The Contract Officer may require any and all questions be submitted in writing. Offerors are encouraged to submit written questions via electronic mail or facsimile, at least five days prior to the proposal due date. Any correspondence related to a solicitation should refer to the appropriate Request for Proposal number, page and paragraph number. An envelope containing questions should be identified as such, otherwise it may not be opened until after the official proposal due date and time. Oral interpretations or clarifications will be without legal effect. Only questions answered by a formal written amendment to the Request for Proposal will be binding.

4. **AMENDMENT OF REQUEST FOR PROPOSAL:** The Offeror shall acknowledge receipt of a Request for Proposal Amendment by signing and returning the document by the specified due date and time.
5. **FAMILIARIZATION OF SCOPE OF WORK:** Before submitting a proposal, each offeror shall familiarize itself with the Scope of Work, laws, regulations and other factors affecting contract performance. The Offeror shall be responsible for fully understanding the requirements of the subsequent Contract and otherwise satisfy itself as to the expense and difficulties accompanying the fulfillment of contract requirements. The submission of a proposal will constitute a representation of compliance by the Offeror. There will be no subsequent financial adjustment, other than that provided by the subsequent Contract, for lack of such familiarization.

6. **PREPARATION OF PROPOSAL:**
- A. All proposals shall be on the forms provided in this Request for Proposal package. It is permissible to copy these forms as required. Facsimiles or electronic mail proposals shall not be considered.
 - B. At a minimum, your proposal should include the signed Offer and Acceptance form, signed copies of any solicitation amendments, completed Price Page and your response to all evaluation criteria.

- C. The Offer and Acceptance page shall be signed by a person authorized to submit an offer. An authorized signature on the Offer and Acceptance page, Proposal Amendment(s), or cover letter accompanying the proposal documents shall constitute an irrevocable offer to sell the good and/or service specified herein. Offeror shall submit any additional requested documentation, signifying intent to be bound by the terms of the agreement.
- D. The authorized person signing the proposal shall initial erasure, interlineations or other modifications on the proposal.
- E. In case of error in the extension of prices in the proposal, unit price shall govern when applicable.
- F. Periods of time, stated as a number of days, shall be in calendar days.
- G. It is the responsibility of all offerors to examine the entire Request for Proposal package and seek clarification of any requirement that may not be clear and to check all responses for accuracy before submitting a proposal. Negligence in preparing a proposal confers no right of withdrawal after due date and time.
- H. The City shall not reimburse the cost of developing, presenting, submitting or providing any response to this solicitation. Offeror must list any subcontractors to be utilized in the performance of the services specified herein. For each subcontractor, details on respective qualifications must be included.

7. **PAYMENT DISCOUNTS:** Payment discount periods shall be computed from the date of receipt of the material/service or correct invoice, whichever is later, to the date City's payment warrant is mailed. Unless freight and other charges are itemized, any discount provided shall be taken on full amount of invoice. Payment discounts of twenty-one calendar days or more shall be deducted from the proposed price in determining the price points. However, the City shall be entitled to take advantage of any payment discount offered by a vendor provided payment is made within the discount period. The payment discount shall apply to all purchases and to all payment methods.
8. **TAXES:** The City of Tucson is exempt from federal excise tax, including the federal transportation tax.

9. **PROPOSAL/SUBMITTAL FORMAT:** An original and 6 copies (7 total) of each proposal should be submitted on the forms and in the format specified in the RFP. Offerors shall also submit one electronic copy of the proposal on cd, disc or zip disc in MS Office 2003 or pdf format. Any confidential information shall be submitted on a separate cd, disc or zip disc. The original copy of the proposal should be clearly labeled "Original" and shall be single-sided, three hole punched and in a binder. The material should be in sequence and related to the RFP. The sections of the submittal should be tabbed, clearly identifiable and should include a minimum of the following sections: the completed Offer and Acceptance Form, all signed Amendments, a copy of this RFP document and the Offeror's response to the Evaluation Criteria including the completed Price Page. Failure to include the requested information may have a negative impact on the evaluation of the offeror's proposal.

10. **EXCEPTIONS TO CONTRACT PROVISIONS:** A response to any Request for Proposal is an offer to contract with the City based upon the contract provisions contained in the City's Request for Proposal, including but not limited to, the specifications, scope of work and any terms and conditions. Offerors who wish to propose modifications to the contract provisions must clearly identify the proposed deviations and any proposed substitute language. The provisions of the Request for Proposal cannot be modified without the express written approval of the Director or his designee. If a proposal or offer is returned with modifications to the contract provisions that are not expressly approved in writing by the Director or his designee, the contract provisions contained in the City's Request for Proposal shall prevail.
11. **PUBLIC RECORD:** All proposals submitted in response to this Request for Proposal shall become the property of the City and shall become a matter of public record available for review subsequent to the award notification.
12. **CONFIDENTIAL INFORMATION:** The City of Tucson is obligated to abide by all public information laws. If an Offeror believes that any portion of a proposal, offer, specification, protest or correspondence contains information that should be withheld, a statement advising the Contract Officer of this fact should accompany the submission and the information shall be so identified wherever it appears. The City shall review all requests for confidentially and may provide a written determination to designate specified documents confidential or the request may be denied. Price is not confidential and will not be withheld. If the confidential request is denied, such information shall be disclosed as public information, unless the offeror submits a formal written objection.

13. **CERTIFICATION:** By signature on the Offer and Acceptance page, solicitation Amendment(s), or cover letter accompanying the submittal documents, Offeror certifies:
- A. The submission of the offer did not involve collusion or other anti-competitive practices.
- B. The Offeror shall not discriminate against any employee or applicant for employment in violation of Federal or State law.
- C. The Offeror has not given, offered to give, nor intends to give at any time hereafter, any economic opportunity, future employment, gift, loan, gratuity, special discount, trip, favor, meal or service to a public servant in connection with the submitted offer.

D. The Offeror hereby certifies that the individual signing the submittal is an authorized agent for the Offeror and has the authority to bind the Offeror to the Contract.

14. WHERE TO SUBMIT PROPOSALS: In order to be considered, the Offeror must complete and submit its proposal to the City of Tucson Department of Procurement at the location indicated, prior to or at the exact date and time indicated on the Notice of Request for Proposal page. The Offeror's proposal shall be submitted in a sealed envelope. The words "SEALED PROPOSAL" with the REQUEST FOR PROPOSAL TITLE, REQUEST FOR PROPOSAL NUMBER, PROPOSAL DUE DATE AND TIME and OFFEROR'S NAME AND ADDRESS shall be written on the envelope.

15. LATE PROPOSALS: Late proposals will be rejected.

16. OFFER AND ACCEPTANCE PERIOD: In order to allow for an adequate evaluation, the City requires an offer in response to this solicitation to be valid and irrevocable for ninety (90) days after the proposal due date and time.

17. WITHDRAWAL OF PROPOSAL: At any time prior to the specified solicitation due date and time, an offeror may formally withdraw the proposal by a written letter, facsimile or electronic mail from the Offeror or a designated representative. Telephonic or oral withdrawals shall not be considered.

18. DISCUSSIONS: The City reserves the right to conduct discussions with offerors for the purpose of eliminating minor irregularities, informalities, or apparent clerical mistakes in the proposal in order to clarify an offer and assure full understanding of, and responsiveness to, solicitation requirements.

19. CONTRACT NEGOTIATIONS: Exclusive or concurrent negotiations may be conducted with responsible offeror(s) for the purpose of altering or otherwise changing the conditions, terms and price of the proposed contract unless prohibited. Offerors shall be accorded fair and equal treatment in conducting negotiations and there shall be no disclosure of any information derived from proposals submitted by competing offerors. Exclusive or concurrent negotiations shall not constitute a contract award nor shall it confer any property rights to the successful offeror. In the event the City deems that negotiations are not progressing, the City may formally terminate these negotiations and may enter into subsequent concurrent or exclusive negotiations with the next most qualified firm(s).

20. VENDOR APPLICATION: Prior to the award of a Contract, the successful offeror shall register with the City's Department of Procurement. Registration can be completed at <http://www.tucsonprocurement.com> by clicking on Vendor Services. Please note that email notifications of newly published solicitations and amendments will be provided to those vendors that select email as their preferred delivery method in their vendor record.

21. CITY OF TUCSON BUSINESS LICENSE: It is the responsibility of the Contractor to have a City of Tucson Business License throughout the life of this contract or a written determination from the City's Business License Section that a license is not required. At any time during the contract, the City may request the Contractor to provide a valid copy of the business license or a written determination that a business license is not required. Application for a City Business License can be completed at <http://www.tucsonaz.gov/tax>. For questions contact the City's Business License Section at (520) 791-4566 or email at tax-license@tucsonaz.gov.

22. UPON NOTICE OF INTENT TO AWARD: The apparent successful offeror shall sign and file with the City, within five (5) days after Notice of Intent to Award, all documents necessary to the successful execution of the Contract.

23. AWARD OF CONTRACT: Notwithstanding any other provision of the Request for Proposal, the City reserves the right to:

- (1) waive any immaterial defect or informality;
- (2) reject any or all proposals, or portions thereof;
- (3) reissue the Request for Proposal.

A response to this Request for Proposal is an offer to contract with the City based upon the terms, conditions and Scope of Work contained in the City's Request for Proposal. Proposals do not become contracts unless and until they are executed by the City's Director of Procurement and the City Attorney. A contract has its inception in the award, eliminating a formal signing of a separate contract. All of the terms and conditions of the contract are contained in the Request for Proposal, unless any of the terms and conditions are modified by a Request for Proposal amendment, a Contract Amendment, or by mutually agreed terms and conditions in the Contract documents.

24. PROPOSAL RESULTS: The name(s) of the successful offeror(s) will be posted on the Procurement Department's Internet site at <http://www.tucsonprocurement.com> upon issuance of a Notice of Intent to Award or upon final contract execution.

25. PROTESTS: A protest shall be in writing and shall be filed with the Director of Procurement. A protest of a Request for Proposal shall be received at the Department of Procurement not less than five (5) working days before the Request for Proposal due date. A protest of a proposed award or of an award shall be filed within ten (10) days after issuance of notification of award or issuance of a notice of intent to award, as applicable. A protest shall include:

- A. The name, address, and telephone number of the protestant;
- B. The signature of the protestant or its representative;
- C. Identification of the Request for Proposal or Contract number;
- D. A detailed statement of the legal and factual grounds of protest including copies of relevant documents; and
- E. The form of relief requested.

LOCAL PRICE PREFERENCE FOR GENERAL GOODS AND SERVICES

The Local Price Preference for general goods and services was adopted on June 12, 2012, by the City of Tucson's Mayor and Council. The preference shall apply to solicitations with a projected contract value between the formal solicitation threshold and one million dollars \$1,000,000.

In order to receive the applicable local price preference for general goods and services in accordance with Article III, Section 28-39 of the Tucson Procurement Code, firms are required to submit a Local Preference Eligibility Affidavit with their bid or proposal.

Local Price Preference for general goods and services will be given as follows:

Type A Business - The principal business office of the enterprise (defined as the domestic address on record with the Arizona Corporation Commission [ACC]) is physically located within the Tucson Metropolitan Area (i.e., within Pima County) and is eligible for a bid price preference of 5%.

Type B Business - The principal business office of the enterprise (defined as the domestic address on record with the Arizona Corporation Commission) is physically located outside the Tucson Metropolitan Area (i.e., within Pima County) but within the State of Arizona and is eligible for a bid preference of 3%.

Type C Business - The business operates as a franchise within the Tucson Metropolitan Statistical Area (i.e., within Pima County), is owned (majority share) by a local resident (i.e., within Pima County), and has the right to operate a business that is identified or associated with a franchisor's trademark, or to offer, sell, or distribute goods, services, or commodities that are identified or associated with a franchisor's trademark, and is eligible for a bid preference of 1.5%.

In determining the lowest responsive and responsible bid or lowest fee proposal, any offer entitled to a Local Price Preference shall be evaluated by reducing the price(s) of such offer by the appropriate percentage described above. This adjustment shall be solely for the purpose of establishing the apparent low bidder or assigning fee points for proposal evaluation. The actual value of any contract award shall be the amount of the actual offer submitted by the bidder/offeror.

Local Preference Eligibility Affidavit

Solicitation #: 151089 Solicitation Title: Body Worn Cameras and Storage System

I, Jeff Kulowski, Business Owner or Officer (Please Print), hereby certify that TASER International, Business Name (Please Print)

meets the requirements of the Tucson Procurement Code, Article III, Section 28-39, to receive preference as indicated below for the above-referenced City of Tucson Solicitation.

This form must be submitted at time of bid/offer submission. Please select just one:

 Type A Business - The principal business office of the enterprise (defined as the domestic address on record with the Arizona Corporation Commission [ACC]) is physically located within the Tucson Metropolitan Statistical Area (i.e., Pima County) and is eligible for a bid price preference of 5%.

Type B Business - The principal business office of the enterprise (defined as the domestic address on record with the Arizona Corporation Commission) is physically located outside the Tucson Metropolitan Statistical Area (i.e., Pima County) but within the State of Arizona and is eligible for a bid preference of 3%.

 Type C Business - The business operates as a franchise within the Tucson Metropolitan Statistical Area (i.e., Pima County), is owned (majority share) by a local resident (i.e., Pima County), and has the right to operate a business that is identified or associated with a franchisor's trademark, or to offer, sell, or distribute goods, services, or commodities that are identified or associated with a franchisor's trademark, and is eligible for a bid preference of 1.5%.

I declare under penalty of perjury under the laws of the State of Arizona that the foregoing is true and correct, and that, if called upon to testify, I will be competent to testify thereto. The City of Tucson has the unilateral right to conduct investigations to confirm eligibility, and the City reserves any and all recourse available to it under Arizona law for failure to provide true and correct information on this Affidavit. In addition, the City may seek suspension and debarment as provided for under the Tucson Procurement Code for failure to provide true and correct information.

Signature: [Handwritten Signature]
Date: 10/14/14

Owner/Officer: Jeff Kulowski
Title: COO
Address: 13600 N 85TH ST
City/State/Zip: Scottsdale AZ 85255
Phone Number: 602/948-2234
Email: sales@taser.com

PROPOSAL EVALUATION REQUIREMENTS

I. PROPOSAL EVALUATION CRITERIA – (listed in relative order of importance)

A. Method of Approach

B. Qualifications & Experience

C. Price Proposal

II. REQUIREMENTS SPECIFIC TO EVALUATION CRITERIA: The narrative portion and the materials presented in response to this Request for Proposal should be submitted in the same order as requested and must contain, at a minimum, the following:

A. Method of Approach

1. What is the name and current version of the product(s) being proposed (camera, hardware, and software)?

2. How long has each product component/product suite being proposed been on the market and in production status?

3. What are your plans for future releases product and software?

4. Provide a comprehensive list with descriptions and pricing of all supplemental equipment.

5. Provide the City your proposed method of evidence storage. The Police department is open to any method evidence storage. Provide a detailed pricing list of all components required for storage (hardware costs, rates for cloud storage, etc.)

6. Briefly list a three year history of software releases for the product being proposed (include dates, versions, and major enhancements for each release).

7. Describe any umbrella portal entrance into the various modules.

9. Provide a list of any additional software required.
10. Provide software and licensing requirements to be included as part of this project.

11. Provide the camera storage capacity.

12. Provide the capacity of the camera memory.

13. Provide the process to get the audio/video from the camera/laptop to the server.

14. Is the process automated?

15. If yes, can it be set up to be automated with DIMS?

16. Provide the minimum required memory (RAM).

17. Provide the minimum required processor speed.

18. Provide the recommended network connection for audio/video upload.

19. Provide the minimum network speed.

20. In terms of the overall system design, describe the aspects of control and auditing. The system should not preclude, by way of its own design, the assessment of control aspects, compliance, electronic evidence, vulnerability, and data reliability.

21. Describe the standard training package included with the purchase of the client management software.

22. Provide all standard reports as Appendix A.

23. Provide a detailed description of your training concept and materials?

24. Identify the technical support and assistance that will include, but not be limited to, the following: devices worn by police personnel, docking/charging stations, networking equipment, WAN/LAN connectivity, system software, system upgrades and video retrieval software and procedures.

25. Provide days and hours that support is available?

26. Provide methods of support contact? (email, telephone, real time online, etc)

27. Provide average problem resolution time?

28. Provide average support call back time?

29. The City desires an aggressive implementation schedule. Please provide your proposed implementation schedule (starting from date of contract award), state the assumptions that are implicit in your assumptions not being met.

30. The City will perform overall project management. Describe what provisions you will make to provide a project manager for your staff who will support overall project objectives and work effectively with the City project manager and staff.

31. Please attach a high-level project schedule, with milestones from each implementation phase.

26. Describe your approach to project communication, the strategy, the calendar, and responsible parties

B. Qualifications & Experience

1. Please provide a list of all government (or comparable) installations, within the last three years, in metro areas over 250,000 in population, with contact names, positions, e-mail addresses, and telephone numbers.

2. Name, corporate address, and number of years in business under current company organization.

3. Type and number of employees committed to the product and support being proposed.

4. Please provide, as Appendix B, a description of business and development plans for all product and support services proposed in connection with this submission.

5. Briefly describe your own project management methodology.

C. Price Proposal - Included in proposal document

1. Provide price proposal as requested on the Price Page attached herein.

2. As stated in the instructions to Offerors, 7. Discounts, the price(s) herein can be discounted by _____%, if payment is made within _____ days. These payment terms shall apply to all purchases and to all payment methods.

3. Cooperative Purchasing Program: Will your firm provide the City of Tucson, as the lead agency on this regional contract, a rebate in the form of a percentage of sales based upon the other agencies sales?

Yes _____ No _____ If yes, state proposed percentage: _____%

4. Will payment be accepted via commercial credit card? Yes _____ No _____

a. If yes, can commercial payment(s) be made online? Yes _____ No _____

b. Will a third party be processing the commercial credit card payment(s)? Yes _____ No _____

c. If yes, indicate the flat fee per transaction \$ _____ (as allowable, per Section 5.2.E of Visa Operating Regulations).

d. If "no" to above, will consideration be given to accept the card? Yes _____ No _____

5. Does your firm have a City of Tucson Business License? Yes _____ No _____
If yes, please provide a copy of your City of Tucson Business license.

III. GENERAL

A. Shortlist:

The City reserves the right to shortlist the offerors on all evaluation criteria except price. However, the City may determine that shortlisting is not necessary.

B. Interviews:

The City reserves the right to conduct interviews with some or all of the offerors at any point during the evaluation process. However, the City may determine that interviews are not necessary. In the event interviews are conducted, information provided during the interview process shall be taken into consideration when evaluating the stated criteria. The City shall not reimburse the offeror for the costs associated with the interview process.

C. Additional Investigations:

The City reserves the right to make such additional investigations as it deems necessary to establish the competence and financial stability of any offeror submitting a proposal.

D. Prior Experience:

Experiences with the City and entities that evaluation committee members represent and that are not specifically mentioned in the solicitation response may be taken into consideration when evaluating offers.

E. Multiple Awards:

To provide adequate contract coverage, at the City's sole discretion, multiple awards may be made.

SPECIAL TERMS AND CONDITIONS

1. **COOPERATIVE PURCHASING:** Any Contract resulting from this solicitation shall be for the use of the City of Tucson. In addition, public and nonprofit agencies that have entered into a Cooperative Purchasing Agreement with the City of Tucson's Department of Procurement are eligible to participate in any subsequent Contract. See http://www.tucsonprocurement.com/coop_partners.aspx and click on Cooperatives for a list of the public and nonprofit agencies that have currently entered into Cooperative Purchasing Agreements with the City of Tucson. Additionally, this contract is eligible for use by the Strategic Alliance for Volume Expenditures (SAVE) cooperative. See <http://www.maricopa.gov/Materials/PubDocuments/SAVE-members.pdf> for a listing of participating agencies. The parties agree that these lists are subject to change. Any orders placed to, or services required from, the successful Contractor(s) will be requested by each participating agency. Payment for purchases made under this agreement will be the sole responsibility of each participating agency. The Contractor may negotiate additional expenses incurred as a result of participating agencies' usage of this contract (i.e., freight charges, travel related expenses, etc.). The City shall not be responsible for any disputes arising out of transactions made by others.
- The Contractor(s) will provide an electronic copy of the complete Contract to the City of Tucson Department of Procurement upon receipt of the Notice of Intent to Award. At the City's request, the successful Contractor(s) may also be requested to provide an electronic copy of the complete Contract to a participating agency.
2. **FOB DESTINATION FREIGHT PREPAID:** Prices shall be FOB Destination Freight Prepaid to the delivery location designated. Contractor shall retain title and control of all goods until they are delivered and the Contract of coverage has been completed. All risk of transportation and all related charges shall be the responsibility of the Contractor. All claims for visible or concealed damage shall be filed by the Contractor. The City will assist the Contractor in arranging for inspection.
3. **PRICE ADJUSTMENT:** The City will review fully documented requests for price adjustment after any Contract has been in effect for one (1) year. Any price adjustment will only be made at the time of Contract renewal and/or extension and will be a factor in the extension review process. The City will determine whether the requested price adjustment or an alternate option, is in the best interest of the City. Any price adjustment will be effective upon the effective date of the Contract extension.
4. **TERM AND RENEWAL:** The term of the Contract shall commence upon award and shall remain in effect for a period of one (1) year, unless terminated, canceled or extended as otherwise provided herein. The Contractor agrees that the City of Tucson shall have the right, at its sole option, to renew the Contract for four (4) additional one-year periods or portions thereof. In the event that the City exercises such rights, all terms, conditions and provisions of the original Contract shall remain the same and apply during the renewal period with the possible exception of price and minor scope additions and/or deletions.

STANDARD TERMS AND CONDITIONS

1. **ADVERTISING:** Contractor shall not advertise or publish information concerning this Contract without prior written consent of the City's Director of Procurement.

2. **AFFIRMATIVE ACTION:** Contractor shall abide by the provisions of the Tucson Procurement Code Chapter 28, Article XII.

3. **AMERICANS WITH DISABILITIES ACT:** The Contractor shall comply with all applicable provisions of the Americans with Disabilities Act (Public Law 101-336, 42 U.S.C. 12101, et seq.) and applicable Federal regulations under the Act.

4. **APPLICABLE LAW:** This Contract shall be governed, and the City and Contractor shall have all remedies afforded to each, by the Tucson Procurement Code and the law of the State of Arizona. State law claims shall be brought only in Pima County Superior Court.

5. **ASSIGNMENT-DELEGATION:** No right or interest in this Contract shall be assigned by the Contractor without prior written permission of the City, and no delegation of any duty of the Contractor shall be made without prior written permission of the City's Director of Procurement. The City shall not unreasonably withhold approval and shall notify the Contractor of the City's position by written notice.

6. **CHILD/SWEAT-FREE LABOR POLICY:** The Contractor shall comply with all applicable provisions of the United States Federal and State Child Labor and Worker's Right laws and agrees if called upon to affirm in writing, that they, and any subcontractor involved in the provision of goods to the City, are in compliance.

7. **CLEAN UP:** The Contractor shall at all times keep the contract area, including storage areas used by the Contractor, free from accumulation of waste material or rubbish and, prior to completion of the work, remove any rubbish from the premises and all tools, scaffolding, equipment and materials not property of the City. Upon completion of the repair, the Contractor shall leave the work and premises in clean, neat and workmanlike condition.

8. **COMMENCEMENT OF WORK:** The Contractor is cautioned not to commence any billable work or provide any material or service under this Contract until Contractor receives purchase order or is otherwise directed to do so, in writing, by the City.

9. **CONFIDENTIALITY OF RECORDS:** The Contractor shall establish and maintain procedures and controls that are acceptable to the City for the purpose of assuring that no information contained in its records or obtained from the City or from others in carrying out its functions under the Contract shall be used by or disclosed by it, its agents, officers, or employees, except as required to efficiently perform duties under the Contract. Persons requesting such information should be referred to the City. Information pertaining to individual persons shall not be divulged other than to employees or officers of Contractor as needed for the performance of duties under the Contract, unless otherwise agreed to in writing by the City.

10. **CONTRACT AMENDMENTS:** The Procurement Department has the sole authority to:

- A. Amend the contract or enter into supplemental verbal or written agreements;
- B. Grant time extensions or contract renewals;
- C. Otherwise modify the scope or terms and provisions of the contract.

This Contract shall only be modified with the approval of the Department of Procurement. Except in the case of a documented emergency, approval must be granted prior to performance. Any contract modification not explicitly approved by the Procurement Department through a written contract amendment or change order is performed at the sole risk of the Contractor and may not be eligible for payment by the City.

11. **CONTRACT:** The Contract shall be based upon the Request for Proposal issued by the City and the Offer submitted by the Contractor in response to the Request for Proposal. The offer shall substantially conform to the terms, conditions, specifications and other requirements set forth within the text of the Request for Proposal. The City reserves the right to clarify any contractual terms with the concurrence of the Contractor, however, any substantial non-conformity in the offer, as determined by the City's Director of Procurement, shall be deemed non-responsive and the offer rejected. The Contract shall contain the entire agreement between the City of Tucson and the Contractor relating to this requirement and shall prevail over any and all previous agreements, contracts, proposals, negotiations, purchase orders, or master agreements in any form.

12. **DEFAULT IN ONE INSTALLMENT TO CONSTITUTE TOTAL BREACH:** Contractor shall deliver conforming materials in each installment or lot of this Contract and may not substitute nonconforming materials. Delivery of nonconforming

materials, or default of any nature, may constitute breach of the Contract. Noncompliance may be deemed a cause for possible Contract termination.

13. DUPLEXED/RECYCLED PAPER: In accordance with efficient resource procurement and utilization policies adopted by the City of Tucson, the Contractor shall ensure that, whenever practicable, all printed materials produced by the Contractor in the performance of this Contract are duplexed (two-sided copies), printed on recycled paper and labeled as such.

14. EXCLUSIVE POSSESSION: All services, information, computer program elements, reports and other deliverables created under this Contract are the sole property of the City of Tucson and shall not be used or released by the Contractor or any other person except with prior written permission by the City.

15. FEDERAL IMMIGRATION LAWS AND REGULATIONS: Contractor warrants that it complies with all Federal Immigration laws and regulations that relate to its employees and complies with A.R.S. § 23-214(A) and that it requires the same compliance of all subcontractors under this Contract. Contractor acknowledges that pursuant to A.R.S. § 41-4401 and effective September 30, 2008, a breach of this warranty is a material breach of this Contract subject to penalties up to and including termination of this Contract. The City retains the legal right to audit the records of the Contractor and inspect the papers of any employee who works for the Contractor to ensure compliance with this warranty and the Contractor shall assist in any such audit. The Contractor shall include the requirements of this paragraph in each contract with subcontractors under this Contract.

If the Contractor or subcontractor warrants that it has complied with the employment verification provisions prescribed by sections 274(a) and 274(b) of the Federal Immigration and Nationality Act and the E-verify requirements prescribed by A.R.S. § 23-214(A), the Contractor or subcontractor shall be deemed to be in compliance with this provision. The City may request proof of such compliance at any time during the term of this Contract by the Contractor and any subcontractor.

16. FORCE MAJEURE: Except for payment of sums due, neither party shall be liable to the other nor deemed in default under this Contract if and to the extent that such party's performance of this Contract is prevented by reason of Force Majeure. The term "Force Majeure" means an occurrence that is beyond the control of the party affected and occurs without its fault or negligence. Force Majeure shall not include late performance by a subcontractor unless the delay arises out of a Force Majeure occurrence in accordance with this Force Majeure term and condition.

If either party is delayed at any time in the progress of the work by Force Majeure, the delayed party shall notify the other party in writing of such delay, as soon as is practical, of the commencement thereof and shall specify the causes of such delay in such notice. Such notice shall be hand-delivered or mailed certified-return receipt and shall make a specific reference to this article, thereby invoking its provisions. The delayed party shall cause such delay to cease as soon as practicable and shall notify the other party in writing when it has done so. The time of completion shall be extended by contract modification for a period of time equal to the time that results or effects of such delay prevent the delayed party from performing in accordance with this Contract.

17. GRATUITIES: The City may, by written notice to the Contractor, terminate this Contract if it is found that gratuities, in the form of entertainment, gifts, meals or otherwise, were offered or given by the Contractor or any agent or representative of the Contractor, to any officer or employee of the City amending, or the making of any determinations with respect to the performing of such Contract. In the event this Contract is terminated by the City pursuant to this provision, the City shall be entitled, in addition to any other rights and remedies, to recover or withhold from the Contractor the amount of the gratuity.

18. HUMAN RELATIONS: Contractor shall abide by the provisions of the Tucson City Code Chapter 28, Article XII.

19. INDEMNIFICATION: To the fullest extent permitted by law, Contractor, its successors, assigns and guarantors, shall pay, defend, indemnify and hold harmless the City of Tucson, its agents, representatives, officers, directors, officials and employees from and against all allegations, demands, proceedings, suits, actions, claims, including claims of patent or copyright infringement, damages, losses, expenses, including but not limited to, attorney fees, court costs, and the cost of appellate proceedings, and all claim adjusting and handling expense, related to, arising from or out of or resulting from any actions, acts, errors, mistakes or omissions caused in whole or part by Contractor relating to work, services and/or products provided in the performance of this Contract, including but not limited to, any Subcontractor or anyone directly or indirectly employed by any of them or anyone for whose acts any of them may be liable and any injury or damages claimed by any of Contractor's and Subcontractor's employees. If Contractor or any of Contractor's employees are certified to receive a premium tax credit or cost sharing reduction which triggers a §4980H (a) or (b) penalty against the City, the Contractor shall indemnify the City from and shall pay any assessed tax penalty.

20. INDEPENDENT CONTRACTOR: It is understood that each party shall act in its individual capacity and not as an agent, employee, partner, joint venture, or associate of the other. An employee or agent of one party shall not be deemed or construed to be the employee or agent of the other party for any purpose.

The Contractor shall not be entitled to compensation in the form of salaries, holidays, paid vacation, sick days, or pension contributions by the City. The City of Tucson will not provide any insurance coverage to the Contractor, including Workers' Compensation coverage. The Contractor is advised that taxes, social security payments, and other withholdings shall not be withheld from a City payment issued under this Contract and that Contractor should make arrangements to directly pay such expenses. Contractor is responsible for compliance with the Affordable Care Act for Contractor and any of Contractor's employees.

21. INSPECTION AND ACCEPTANCE: All material or service is subject to final inspection and acceptance by the City. Material or service failing to conform to the specifications of this Contract shall be held at the Contractor's risk and may be returned to the Contractor. If returned, all costs are the responsibility of the Contractor. Noncompliance may be deemed a cause for possible Contract termination.

22. INTERPRETATION-PAROLE EVIDENCE: This Contract is intended by the parties to be a final expression of their agreement and is intended also as a complete and exclusive statement of the terms of this agreement. No course of prior dealings between the parties and no usage of the trade shall be relevant to supplement or explain any term used in the Contract. Acceptance or consent in the course of performance under this Contract shall not be relevant to determine the meaning of this Contract even though the accepting or consenting party has knowledge of the nature of the performance and the opportunity to object.

23. LICENSES: Contractor shall maintain in current status all Federal, State, and local licenses and permits required for the operation of the business conducted by the Contractor as applicable to this Contract.

24. LIENS: All materials, services, and other deliverables supplied to the City under this Contract shall be free of all liens other than the security interest. Security interest shall extinguish upon full payment made by the City. Upon the City's request, the Contractor shall provide a formal release of all liens.

25. NO REPLACEMENT OF DEFECTIVE TENDER: Every tender of materials must fully comply with all provisions of this Contract. If a tender is made which does not fully comply, this shall conform to the termination clause set forth within this document.

26. NON-EXCLUSIVE CONTRACT: Any contract resulting from this solicitation shall be awarded with the understanding and agreement that it is for the sole convenience of the City of Tucson. The City reserves the right to obtain like goods or services from another source when necessary.

27. OVERCHARGES BY ANTITRUST VIOLATIONS: The City maintains that, in actual practice, overcharges resulting from antitrust violations are borne by the purchaser. Therefore, to the extent permitted by law, the Contractor hereby assigns to the City any and all claims for such overcharges as to the materials or services used to fulfill the Contract.

28. PAYMENT: The City's preferred method of payment is via credit card. The City will issue a Purchase Order and, in some cases, either provide a credit card for payment at the time of ordering or pay subsequent invoices by credit card upon receipt of goods or services in good order. However, not all City employees will possess a credit card and, therefore, the City reserves the right to make payment by check as it deems necessary.

Unless payment is made by credit card at time of order or point of sale, a separate invoice shall be issued for each shipment of material or service performed, and no payment shall be issued prior to receipt of material or service and correct invoice.

The City shall make every effort to process payment for the purchase of materials or services within twenty-one (21) calendar days after receipt of materials or services and a correct invoice.

The Contractor's payment terms shall apply to all purchases and to all payment methods.

29. PROTECTION OF GOVERNMENT PROPERTY: The Contractor shall use reasonable care to avoid damaging existing buildings, equipment, and vegetation (such as trees, shrubs, and grass) on City property. If the Contractor fails to do so and damages such property, the Contractor shall replace or repair the damage at no expense to the City, as determined and approved by the City's Director of Procurement. If the Contractor fails or refuses to make such repair or replacement, the City will determine a cost and the Contractor shall be liable for the cost thereof, which may be deducted from the Contract price.

30. PROVISIONS REQUIRED BY LAW: Each and every provision of law and any clause required by law to be in the Contract shall be read and enforced as though it were included herein, and if through mistake or otherwise any such provision is not inserted, or is not correctly inserted, then upon the application of either party the Contract shall be amended to make such insertion or correction.

31. RECORDS: Internal control over all financial transactions related to this Contract shall be in accordance with sound fiscal policies. The City may, at reasonable times and places, audit the books and records of the Contractor and/or any subcontractors. Said audit shall be limited to this Contract.

32. RIGHT TO ASSURANCE: Whenever one party to this Contract has reason to question, in good faith, the other party's intent to perform, the former party may demand that the other party give a written assurance of this intent to perform. In the event that a demand is made and no written assurance is given within five (5) days, the demanding party may treat this failure as the other party's intent not to perform and as a cause for possible Contract termination.

33. RIGHT TO INSPECT: The City may, at reasonable times, and at the City's expense, inspect the place of business of a Contractor or subcontractor which is related to the performance of any Contract as awarded or to be awarded.

34. RIGHTS AND REMEDIES: No provision in this document or in the Contractor's proposal shall be construed, expressly or by implication, as a waiver by either party of any existing or future right and/or remedy available by law in the event of any claim, default or breach of contract. The failure of either party to insist upon the strict performance of any term or condition of the Contract, to exercise or delay the exercise of any right or remedy provided in the Contract or by law, or to accept materials or services required by this Contract or by law shall not be deemed a waiver of any right of either party to insist upon the strict performance of the Contract.

35. SEVERABILITY: The provisions of this Contract are severable to the extent that any provision or application held to be invalid shall not affect any other provision or application of the Contract which may remain in effect without the valid provision or application.

36. SHIPMENT UNDER RESERVATION PROHIBITED: No tender of a bill of lading shall operate as a tender of the materials. Non-compliance shall conform to the termination clause set forth within this document.

37. SUBCONTRACTS: No subcontract shall be entered into by the Contractor with any other party to furnish any of the material/service specified herein without the advance written approval of the City's Director of Procurement. All subcontracts shall comply with Federal and State laws and regulations which are applicable to the services covered by the subcontract and shall include all the terms and conditions set forth herein which shall apply with equal force to the subcontract, as if the subcontractor were the Contractor referred to herein. The Contractor is responsible for contract performance whether or not subcontractors are used.

38. SUBSEQUENT EMPLOYMENT: The City may terminate this Contract without penalty or further obligation pursuant to A.R.S. Section 38-511 if any person significantly involved in initiating, negotiating, securing, drafting, or creating the Contract, on behalf of the City, is or becomes, at any time while the Contract or any extension of the Contract is in effect, an employee of, or a contractor to, any other party to this Contract with respect to the subject matter of the Contract. Termination shall be effective when written notice from the City's Director of Procurement is received by the parties to this Contract, unless the notice specifies a later time.

39. TERMINATION OF CONTRACT: This Contract may be terminated at any time by mutual written consent, or by the City, with or without cause, upon giving thirty (30) days written notice. The City, at its convenience, by written notice, may terminate this Contract, in whole or in part. If this Contract is terminated, the City shall be liable only for payment under the payment provisions of this Contract for services rendered and accepted material received by the City before the effective date of termination.

The City reserves the right to terminate the whole or any part of this Contract due to the failure of the Contractor to carry out any term or condition of the Contract. The City will issue a written ten (10) day notice of default to the Contractor for acting or failing to act as specified in any of the following:

In the opinion of the City, the Contractor provides personnel that do not meet the requirements of the Contract;

In the opinion of the City, the Contractor fails to perform adequately the stipulations, conditions or services/specifications required in this Contract;

In the opinion of the City, the Contractor attempts to impose personnel, materials, products or workmanship of an unacceptable quality;

The Contractor fails to furnish the required service and/or product within the time stipulated in the Contract;

In the opinion of the City, the Contractor fails to make progress in the performance of the requirements of the Contract;

The Contractor gives the City a positive indication that the Contractor will not or cannot perform to the requirements of the Contract.

Each payment obligation of the City created by this Contract is conditioned upon the availability of City, State and Federal funds that are appropriated or allocated for the payment of such an obligation. If funds are not allocated by the City and available for the continued purchase of the services and/or materials provided under this Contract, this Contract may be terminated by the City at the end of the period for which funds are available. The City will endeavor to notify the Contractor in the event that continued service will or may be affected by non-appropriation. No penalty shall accrue to the City in the event this provision is exercised, and the City shall not be obligated or liable for any future payments due or for any damages as a result of termination under this paragraph.

40. TITLE AND RISK OF LOSS: The title and risk of loss of material or service shall not pass to the City until the City actually receives the material or service at the point of delivery, unless otherwise provided within this Contract.

41. WARRANTIES: Contractor warrants that all material or service delivered under this Contract shall conform to the specifications of this Contract. Mere receipt of shipment of the material or service specified and any inspection incidental thereto by the City shall not alter or affect the obligations of the Contractor or the rights of the City under the foregoing warranties. Additional warranty requirements may be set forth in this document.

PRICE PAGE

Included in proposal

Item No.	Description	Estimated Annual Quantity	Unit Price	Extended Price
1	Body Worn Camera, as per specification	40 Each	\$ _____	\$ _____
	Manufacturer and Model #			
2	Software, as per specification	40 Each	\$ _____	\$ _____
	Manufacturer and Model #			
3	Initial Product Training	40	\$ _____ per person	\$ _____
4	Train the Trainer program	1	\$ _____ per class	\$ _____

OFFER AND ACCEPTANCE

OFFER

TO THE CITY OF TUCSON:
The Undersigned hereby offers and shall furnish the material or service in compliance with all terms, scope of work, conditions, specifications, and amendments in the Request for Proposal which is incorporated by reference as if fully set forth herein.

For clarification of this offer, contact:

TASER International Inc Company Name
17800 N 85th St Address
Scottsdale AZ 85255 City
State Zip
[Signature] Signature of Person Authorized to Sign
Jeff Kukonick Printed Name
COO Title

Maureen Harman Name
Sales Operations Coordinator Title
800/978-2737 Phone
480/991-0791 Fax
Maureen@taser.com E-mail

The Offer is hereby accepted. The Contractor is now bound to sell the materials or services specified in the Contract. This Contract shall be referred to as Contract No. 151754

ACCEPTANCE OF OFFER

CITY OF TUCSON, a municipal corporation
Awarded this 2nd day of February, 2014
Maureen Harman
Marcheta Gillespie, C.P.M., CPPO, CPPB, CPM
As Director of Procurement and not personally

Approved as to form this 3rd day of Feb, 2014
[Signature]
As Tucson City Attorney and not personally

TASER International
reject Truth

17800 N 85th St.
 Scottsdale, Arizona 85255
 United States
 Phone: (800) 978-2737
 Fax:

TASER



Quotation

Quote: Q-18016-1
 Date: 9/26/2014 12:09 PM
 Quote Expiration: 11/30/2014
 Contract Start Date*: 12/15/2014
 Contract Term: 3 years

Joe Puglia
 (520) 791-4467
 joe.puglia@tucsonaz.gov

Ship To:
 Joe Puglia
 Tucson Police Dept. - AZ
 270 S. Stone Avenue
 Tucson, AZ 85701
 US

Bill To:
 Tucson Police Dept. - AZ
 270 S. Stone Avenue
 Tucson, AZ 85701
 US

SALESPERSON	PHONE	EMAIL	DELIVERY METHOD	PAYMENT METHOD
Laurie Bain		lbain@taser.com	Fedex - Ground	Net 30

*Note this will vary based on the shipment date of the product.

*This quote reflects a discount for the upgrade program, based upon the number of units that you have indicated will be destroyed. The Certificate of Destruction, provided by TASER, must be completed and submitted with your signed quote/purchase order to obtain the upgrade credit. The credit is reflected as a reduction to the first year payment or your upfront payment for the TASER Assurance Plan, due with your hardware purchase. Please see <http://www.taser.com/upgrade> for current program details.

Year 1--Due Net 30

QTY	ITEM #	DESCRIPTION	UNIT PRICE	Total Before Discount	DISC (\$)	NET TOTAL
40	73030	KIT, AXON, FLEX	499.95	USD 19,998.00	USD 0.00	USD 19,998.00
40	73009	COLLAR/VERSATILE/CAP MOUNT, FLEX		USD 0.00	USD 0.00	USD 0.00
40	73036	CONTROLLER, HOLSTER, BELT CLIPS, FLEX		USD 0.00	USD 0.00	USD 0.00
40	85074	3 YEAR TASER ASSURANCE PLAN AXON FLEX		USD 0.00	USD 0.00	USD 0.00
7	70026	EVIDENCE.COM, DOCK, SIX CAMERA BAYS+HUB	1495.00	USD 10,465.00	USD 0.00	USD 10,465.00
7	85091	3 YEAR TASER ASSURANCE PLAN ETM HUB		USD 0.00	USD 0.00	USD 0.00
7	85093	3 YEAR TASER ASSURANCE PLAN ETM 6 BAY		USD 0.00	USD 0.00	USD 0.00
40	85079	TASER ASSURANCE PLAN ETM ANNUAL PAYMENT	36.00	USD 1,440.00	USD 0.00	USD 1,440.00
1	85078	ULTIMATE EVIDENCE.COM ANNUAL PAYMENT	588.00	USD 23,520.00	USD 0.00	USD 23,520.00
800	85035	EVIDENCE.COM STORAGE		USD 0.00	USD 0.00	USD 0.00

Subtotal USD 136,243.00

QTY	ITEM #	DESCRIPTION	UNIT PRICE	Total Before Discount	DISC (\$)	NET TOTAL
40	85078	ULTIMATE EVIDENCE.COM ANNUAL PAYMENT	588.00	USD 23,520.00	USD 0.00	USD 23,520.00
800	85035	EVIDENCE.COM STORAGE		USD 0.00	USD 0.00	USD 0.00
10	88301	STANDARD EVIDENCE.COM LICENSE: YEAR 3 PAYMENT	300.00	USD 3,000.00	USD 0.00	USD 3,000.00
100	85035	EVIDENCE.COM STORAGE		USD 0.00	USD 0.00	USD 0.00
3,200	85035	EVIDENCE.COM STORAGE	1.50	USD 4,800.00	USD 0.00	USD 4,800.00
40	85079	TASER ASSURANCE PLAN ETM ANNUAL PAYMENT	36.00	USD 1,440.00	USD 0.00	USD 1,440.00
Year 3--Due 2 Years from Purchase Date Total: USD 32,760.00						
Year 3--Due 2 Years from Purchase Date Net Price: USD 32,760.00						

Year 3--Due 2 Years from Purchase Date

QTY	ITEM #	DESCRIPTION	UNIT PRICE	Total Before Discount	DISC (\$)	NET TOTAL
40	85078	ULTIMATE EVIDENCE.COM ANNUAL PAYMENT	588.00	USD 23,520.00	USD 0.00	USD 23,520.00
800	85035	EVIDENCE.COM STORAGE		USD 0.00	USD 0.00	USD 0.00
10	88201	STANDARD EVIDENCE.COM LICENSE: YEAR 2 PAYMENT	300.00	USD 3,000.00	USD 0.00	USD 3,000.00
100	85035	EVIDENCE.COM STORAGE		USD 0.00	USD 0.00	USD 0.00
3,200	85035	EVIDENCE.COM STORAGE	1.50	USD 4,800.00	USD 0.00	USD 4,800.00
40	85079	TASER ASSURANCE PLAN ETM ANNUAL PAYMENT	36.00	USD 1,440.00	USD 0.00	USD 1,440.00
Year 2--Due 1 Year from Purchase Date Total: USD 32,760.00						
Year 2--Due 1 Year from Purchase Date Net Price: USD 32,760.00						

Year 2--Due 1 Year from Purchase Date

QTY	ITEM #	DESCRIPTION	UNIT PRICE	Total Before Discount	DISC (\$)	NET TOTAL
10	88101	STANDARD EVIDENCE.COM LICENSE: YEAR 1 PAYMENT	300.00	USD 3,000.00	USD 0.00	USD 3,000.00
100	85035	EVIDENCE.COM STORAGE		USD 0.00	USD 0.00	USD 0.00
3,200	85035	EVIDENCE.COM STORAGE	1.50	USD 4,800.00	USD 0.00	USD 4,800.00
1	73030	KIT, AXON, FLEX		USD 0.00	USD 0.00	USD 0.00
1	73009	COLLAR/VERSATILE/CAP MOUNT, FLEX		USD 0.00	USD 0.00	USD 0.00
1	73036	CONTROLLER, HOLSTER, BELT CLIPS, FLEX		USD 0.00	USD 0.00	USD 0.00
1	85074	3 YEAR TASER ASSURANCE PLAN AXON FLEX		USD 0.00	USD 0.00	USD 0.00
1	85055	PREMIUM PLUS SERVICE	1500.00	USD 15,000.00	USD 7,500.00	USD 7,500.00
Year 1--Due Net 30 Total: USD 78,223.00						
Year 1--Due Net 30 Net Price: USD 70,723.00						

Estimated Tax	USD 11,193.70
Grand Total	USD 147,436.70

This quote contains a purchase of either the Basic or Standard Evidence.com license. You will temporarily receive the features available with the Professional license for the Basic and Standard licenses purchased until December 31, 2014. This is a free upgrade to your account so you can enjoy all the benefits of our most feature rich license tier. In January 2015 you will be prompted to select which users you would like to go in which tiers. This will have no impact on uploaded data.

Complimentary Evidence.com Tier Upgrade Through 12/31/2014

TASER International, Inc.'s Sales Terms and Conditions for Direct Sales to End User Purchasers

By signing this Quote, you are entering into a contract and you certify that you have read and agree to the provisions set forth in this Quote and TASER's current Sales Terms and Conditions for Direct Sales to End User Purchasers or, in the alternative, TASER's current Sales Terms and Conditions for Direct Sales to End User Purchasers for Sales with Financing with TASER. If your purchase includes the TASER Assurance Plan (TAP), then you are also agreeing to TASER's current Sales Terms and Conditions for the AXON Flex™ and AXON Body™ Cameras TASER Assurance Plan (U.S. Only) and/or Sales Terms and Conditions for the X2/X26P and TASER CAM HD Recorder TASER Assurance Plan (U.S. Only), as applicable to your product purchase. All of the sales terms and conditions, as well as, the TAP terms and conditions are posted at <http://www.taser.com/sales-terms-and-conditions>. If your purchase includes AXON hardware and/or EVIDENCE.com services you are also agreeing to the terms in the EVIDENCE.com Master Service Agreement posted at <http://www.taser.com/services/agreement14>. If your purchase includes Professional Services, you are also agreeing to the terms in the Professional Service Agreement posted at http://www.taser.com/images/support/downloads/downloads/evidence_materials/Professional_Services_Agreement.pdf. You represent that you are lawfully able to enter into contracts and if you are entering into this agreement for an entity, such as the company, municipality, or government agency you work for, you represent to TASER that you have legal authority to bind that entity. If you do not have this authority, do not sign this Quote.

Signature: _____

Date: _____

Name (Print): _____

Title: _____

PO # (if needed): _____

Please sign and email to Laurie Bath at lbath@taser.com or fax to

THANK YOU FOR YOUR BUSINESS!

'Project Life' and © are trademarks of TASER International, Inc., and TASER® is a registered trademark of TASER International, Inc., registered in the U.S. © 2013 TASER International, Inc. All rights reserved.



17800 N. 85th St
Scottsdale, AZ
85355-9603

Phone: (480) 991-0797 • (800) 978-2737
Fax: (480) 991-0791
www.TASER.com

October 14, 2014

City of Tucson
Department of Procurement
255 W. Alameda, 6th Floor
Tucson, Arizona 85701

RE: EXCEPTIONS/DEVIATIONS TO RFP NUMBER 151089: Body Worn Cameras and Storage System

Ms. Gillian B. Needham:

Please find below TASER International Inc.'s exceptions to the City of Tucson Request for Proposal: 151089. Due
October 20, 2014. TASER International's proposal is contingent upon the following section changes and/or deletions.

1. **SCOPE OF WORK – Page 2, Term 7, WARRANTY:**
Offeror shall warrant that all equipment and parts furnished in their bid/offer are newly manufactured and free from
defects in material and workmanship for no less than one (1) year for products and ninety (90) days for
accessories from the date the equipment is delivered or installed.

2. **SPECIAL TERMS AND CONDITIONS – Page 15, Term 1, COOPERATIVE PURCHASING:**
Any Contract resulting from this solicitation shall be for the use of the City of Tucson. In addition, public and
nonprofit agencies that have entered into a Cooperative Purchasing Agreement with the City of Tucson's
Department of Procurement are eligible to participate in any subsequent Contract approved by the Contractor.
See http://www.tucsonprocurement.com/coop_partners.aspx and click on Cooperatives for a list of the public and
nonprofit agencies that have currently entered into Cooperative Purchasing Agreements with the City of Tucson.
Additionally, this contract is eligible for use by the Strategic Alliance for Volume Expenditures (SAVE) cooperative.

3. **SPECIAL TERMS AND CONDITIONS – Page 15, Term 4, TERM AND RENEWAL:**
The term of the Contract shall commence upon award and shall remain in effect for a period of one (1) year,
unless terminated, canceled or extended as otherwise provided herein. The Contractor agrees that the City of
Tucson shall have the right, at its sole option, to renew the Contract for four (4) additional one-year periods or
portions thereof with approved until price adjustments received from Contractor.

4. **STANDARD TERMS AND CONDITIONS – Page 16, Term 1, ADVERTISING:**
Contractor shall not advertise or publish information concerning this Contract without prior written consent of the
City's Director of Procurement, except for financial reporting obligations to the contractor auditor and the US
Government.

5. **STANDARD TERMS AND CONDITIONS – Page 16, Term 9, CONFIDENTIALITY OF RECORDS:**
The Contractor shall establish and maintain procedures and controls that are acceptable to the City for the
purpose of assuring that no information contained in its records or obtained from the City or from others in carrying
out its functions under the Contract shall be used by or disclosed by its agents, officers, or employees, except
as required to efficiently perform duties under the Contract except for financial reporting obligations to the
contractor auditor and the US Government.

6. **STANDARD TERMS AND CONDITIONS – Page 17, Term 19, INDEMNIFICATION:**

Phone: (480) 991-0797 • (800) 978 2737
Fax: (480) 991-0791
www.TASER.com

17800 N. 85th St
Scottsdale, AZ
85255-9603



To the fullest extent permitted by law, Contractor, its successors, assigns and guarantors, shall pay, defend, indemnify and hold harmless the City of Tucson, its agents, representatives, officers, directors, officials and employees from and against all allegations, demands, proceedings, suits, actions, claims, including claims of patent or copyright infringement, damages, losses, expenses, including but not limited to, attorney fees, court costs, and the cost of appellate proceedings, and all claim adjusting and handling expense, related to, arising from or out of or resulting from any negligent actions, negligent acts, errors, mistakes or willful omissions caused in whole or part by Contractor relating to work, services and/or products provided in the performance of this Contract, including but not limited to, any Subcontractor or anyone directly or indirectly employed by any of them or anyone for whose acts any of them may be liable and any injury or damages claimed by any of Contractor's and Subcontractor's employees. This indemnity and liability obligation does not apply to any claim arising out of the deployment, use, or misuse of the Taser product by the City, its employees or agents, including any claims for damages and personal injuries. The City agrees to assume all risks of loss and all liability for any damages and personal injury which may result from the deployment use, or misuse of the Taser product.

7. STANDARD TERMS AND CONDITIONS – Page 18, Term 21. INSPECTION AND ACCEPTANCE:
All material or service is subject to final inspection and acceptance by the City. After seven (7) calendar days of the City possessing the goods, the goods shall be deemed inspected and accepted.

If there are any questions or concerns please feel free to contact me by phone at: (480)463-2128 or by email: acoleman@TASER.com

Best Regards,

Anthony Coleman
Contracts & Compliance Manager
acoleman@taser.com
480-905-2128

ID	Task Mode	Task Name	Start	Duration	Finish
1		Tuscon PD Project	Mon 10/27/14	9.25 days	Fri 11/7/14
		Configuration Tasks	Mon 10/27/14	5 days	Fri 10/31/14
3		Site survey for ETM installation, test bandwidth	Mon 10/27/14	1 day	Mon 10/27/14
4		ETM registration and configuration	Mon 10/27/14	1 day	Mon 10/27/14
5		Install and test E.com Docks	Mon 10/27/14	1 day	Mon 10/27/14
6		Create user accounts in Evidence.com	Tue 10/28/14	2 hrs	Tue 10/28/14
7		Inventory, assign, test all Axon devices	Tue 10/28/14	1 day	Wed 10/29/14
8		Draft video police created	Mon 10/27/14	5 days	Fri 10/31/14
9		Record/upload test video	Tue 10/28/14	1 hr	Tue 10/28/14
10		Install AXON Mobile & Evidence Mobile App (Done at the time of training)	Mon 10/27/14	1 day	Mon 10/27/14

Task	Manual Summary Rollup	
Split	Manual Summary	
Milestone	Start-only	
Summary	Finish-only	
Project Summary	External Tasks	
Inactive Task	External Milestone	
Inactive Milestone	Deadline	
Inactive Summary	Progress	
Manual Task	Manual Progress	
Duration-only		

Project: Tuscon PD Project Plan 2
Date: Mon 9/29/14

ID	Task Mode	Task Name	Duration	Start	Finish
11		Install MDT Application (SYNC) (Done at the time of training)	1 day	Mon 10/27/14	Mon 10/27/14
12		Draft Deployment Plan created	2 days	Mon 10/27/14	Tue 10/28/14
13		EVIDENCE.COM Training	2 days	Mon 11/3/14	Tue 11/4/14
14		Evidence.com Configuration Meeting	2 hrs	Mon 11/3/14	Mon 11/3/14
15		Train The Trainer	3 hrs	Mon 11/3/14	Mon 11/3/14
16		Evidence.com Super User Training Session 1	3 hrs	Tue 11/4/14	Tue 11/4/14
17		Evidence Tech Training	1.5 hrs	Tue 11/4/14	Tue 11/4/14
18		Tuscon PD Go Live Rollout (40 units)	2 days	Wed 11/5/14	Thu 11/6/14
19		Wave 1 Training	1 day	Wed 11/5/14	Wed 11/5/14
20		Gear Fit and Training - First Shift	3 hrs	Wed 11/5/14	Wed 11/5/14

Task	Manual Summary Rollup	
Split	Manual Summary	
Milestone	Start-only	
Summary	Finish-only	
Project Summary	External Tasks	
Inactive Task	External Milestone	
Inactive Milestone	Deadline	
Inactive Summary	Progress	
Manual Task	Manual Progress	
Duration-only		

ID	Task Mode	Task Name	Duration	Start	Finish
21		Gear Fit and Training - Second Shift	3 hrs	Wed 11/5/14	Wed 11/5/14
22		Wave 2 Training	1 day	Thu 11/6/14	Thu 11/6/14
23		Gear Fit and Training- First Shift	3 hrs	Thu 11/6/14	Thu 11/6/14
24		Gear Fit and Training- Second Shift	3 hrs	Thu 11/6/14	Thu 11/6/14
25		Make up Training	1 day	Thu 11/6/14	Thu 11/6/14
26		Gear Fit and Training- First Shift	3 hrs	Thu 11/6/14	Thu 11/6/14
27		Gear Fit and Training- Second Shift	3 hrs	Thu 11/6/14	Thu 11/6/14
28		Tuscon PD Go Live Complete	0.25 days	Fri 11/7/14	Fri 11/7/14
29		Post Deployment Meeting	2 hrs	Fri 11/7/14	Fri 11/7/14

Date: Mon 9/29/14
Project: Tuscon PD Project Plan 2

Task	Split	Milestone	Summary	Project Summary	Inactive Task	Inactive Milestone	Inactive Summary	Manual Task	Duration-only
Manual Summary Rollup	Manual Summary	Start-only	Finish-only	External Tasks	External Milestone	Deadline	Progress	Manual Progress	

Project: Tuscon PD Project Plan 2
 Date: Mon 9/29/14

Task		Manual Summary Rollup	
Split		Manual Summary	
Milestone		Start-only	
Summary		Finish-only	
Project Summary		External Tasks	
Inactive Task		External Milestone	
Inactive Milestone		Deadline	
Inactive Summary		Progress	
Manual Task		Manual Progress	
Duration-only			

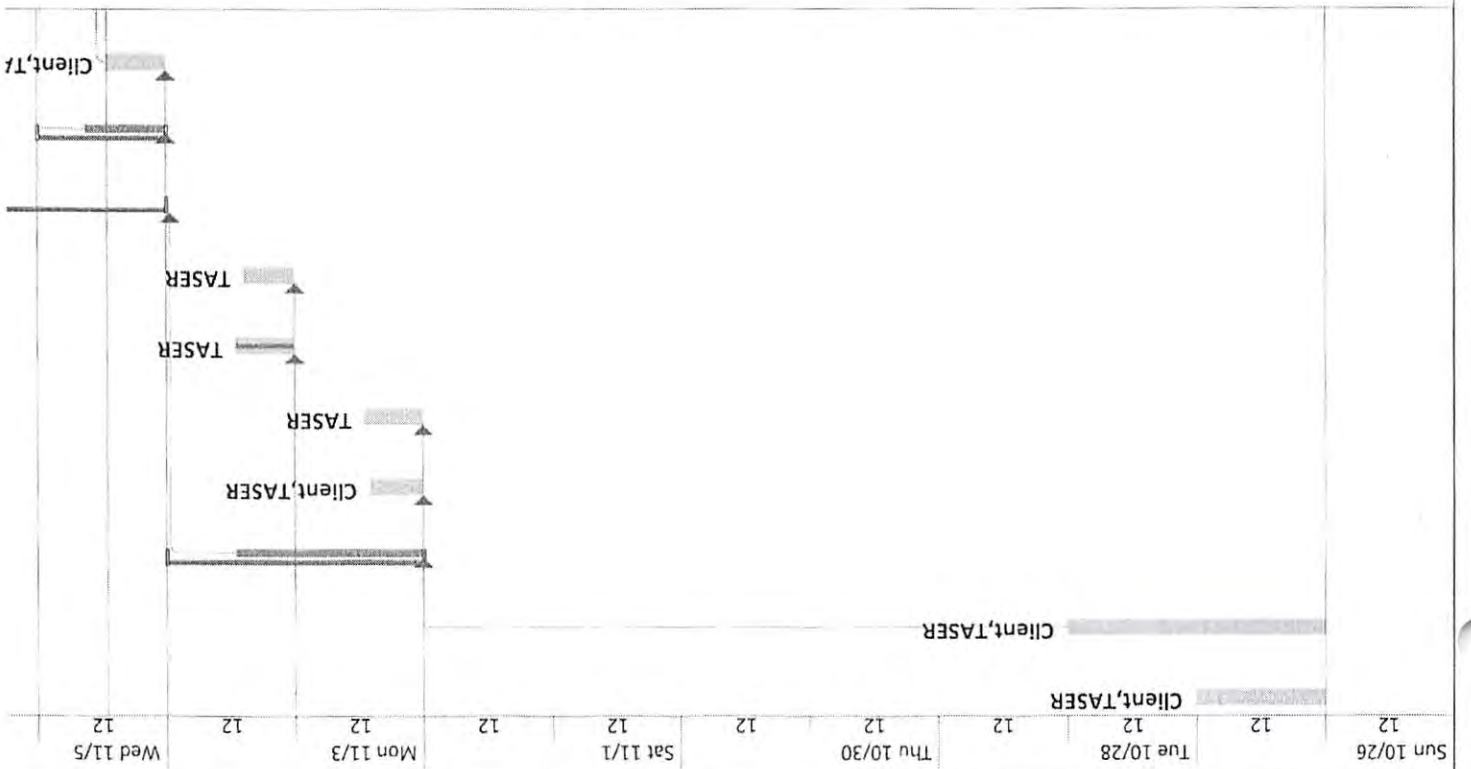

Sun 10/26 12
 Tue 10/28 12
 Thu 10/30 12
 Sat 11/1 12
 Mon 11/3 12
 Wed 11/5 12
 Client,

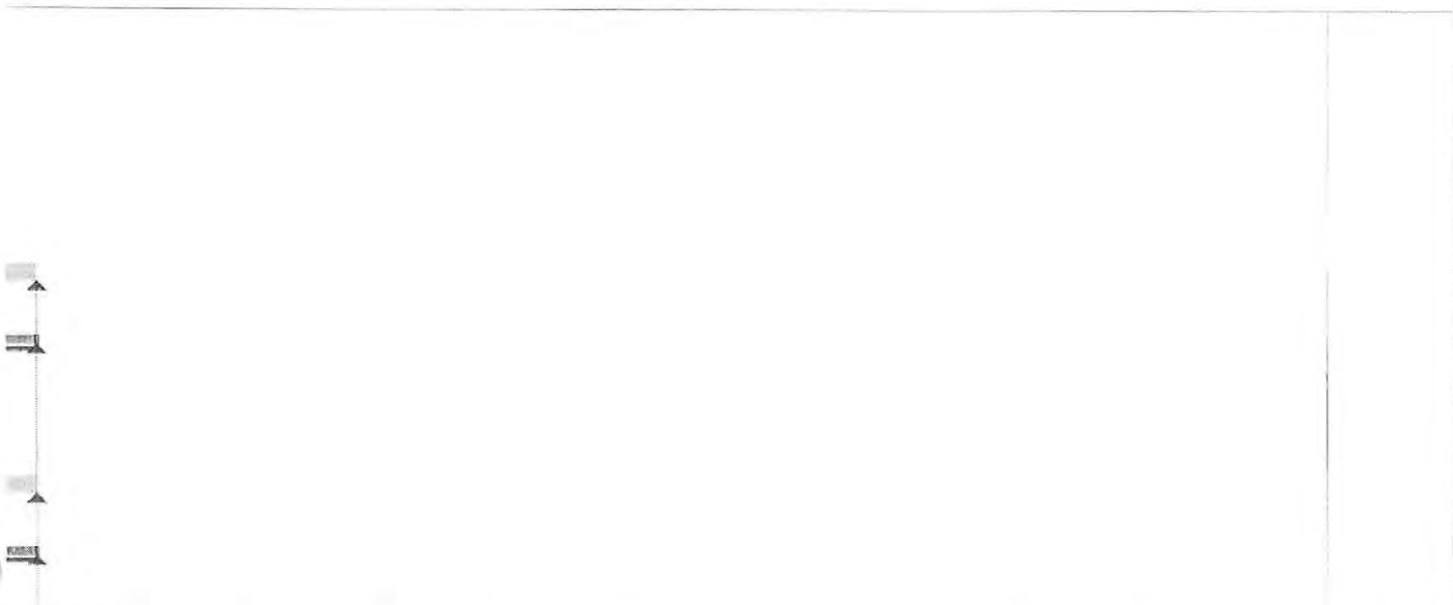

Task	Manual Summary Rollup	
Split	Manual Summary	
Milestone	Start-only	
Summary	Finish-only	
Project Summary	External Tasks	
Inactive Task	External Milestone	
Inactive Milestone	Deadline	
Inactive Summary	Progress	
Manual Task	Manual Progress	
Duration-only		

Project: Tuscon PD Project Plan 2
 Date: Mon 9/29/14

Sample 3

NAME

RETENTION DURATION

Uncategorized

Until manually deleted

1. No Action

26 Weeks

2. F.I.

2 Years

3. Citation, Civil

2 Years

4. Backup *Add Other Cat.

1 Years

5. Citation, Criminal

3 Years

6. Arrest Misd

3 Years

7. Arrest Fel.

10 Years

8. Investigation Misd

3 Years

9. Investigation Fel.

10 Years

Title: TASER International, Inc.'s Sales Terms and Conditions – Direct Sales to End User Purchasers

Department: Legal

Version: 6.0

Release Date: 11/22/2013

TASER International, Inc.'s Sales Terms and Conditions

for Direct Sales to End User Purchasers

(Effective November 22, 2013)

These Sales Terms and Conditions apply to your purchase of all TASER International, Inc. ("TASER," "we," "us," or "our") products and services purchased directly from us. Products and services sold by us are expressly subject to and conditioned upon the terms and conditions set forth below. By signing a quote, issuing a purchase order, or accepting delivery of the product or service, you accept and are bound to these Sales Terms and Conditions. Any different or additional terms set forth by you, whether in your purchase order or another communication, are expressly objected to and will not be binding on us.

Return Policies. All sales are final and no refunds or exchanges are allowed, except as provided by state or federal law and as specified below for TASER® Citizen Products.

Exchanges for TASER Citizen Products. The citizen model products that are unopened and still in their sealed package may be returned or exchanged within 15 days from the date of receipt of the product for a credit or a refund of the purchase price paid, less shipping and handling, and any applicable restocking fees. Any product returned to TASER without prior authorization from us will be considered an unauthorized return, and you will not receive credit for the product and we will not ship the product back to you. Unless the product is defective or the return is a direct result of our error, we may charge a restocking fee of up to 15% of the purchase price paid, plus any applicable sales tax.

To return a citizen model product, you must first go to our website, www.TASER.com and obtain a

Return Material Authorization ("RMA") number before the end of the applicable return period. We will not accept returns without an RMA number. See the Product Warranty, www.TASER.com, or contact us at 800.978.2737 (+1.480.905.2000 for international callers) for information on how to obtain an RMA number. You must ship the product to us within 5 days of the date that we issue the RMA number as follows:

- in the original product packaging, in as-new condition, along with any media, documentation, and any other items that were included in your original shipment;
- at your expense and insured (if you return the product uninsured then you accept the risk of loss or damage during shipment);
- with the RMA number clearly marked on the outside of the return packaging;
- with proof of purchase of the product (receipt, purchase order, or invoice); and
- with your name, address, and phone number of where to send the exchange item or the product credit or refund.

Upon receipt of your return, we will issue a credit or a refund of the purchase price paid, less shipping and handling, and any applicable restocking fees. For partial returns, your credit may be less than the invoice or individual component price due to bundled or promotional pricing or any unadvertised discounts or concessions. If you fail to follow the return or exchange instructions and policies provided by us, we are not responsible for product that is lost, damaged, modified, or otherwise processed for disposal or resale.

Quotes. A quotation is an offer to sell, is valid only for the products and services listed on the quote at the prices listed on the quote, and is subject to these Sales Terms and Conditions, all of which are deemed incorporated into the quote. The quote from TASER contains the entire terms and conditions

associated with the transaction. You may accept a quotation by signing the quote, issuing a purchase order, or other writing expressing your intention to be bound. Any terms, conditions or writing within your purchase order or other writing addressing the subject matter of the transaction, will be for your internal purposes only and the terms and conditions contained therein will have no force or effect. If you have not signed a quote from TASER, then your order is subject to cancellation by us, in our sole discretion. We are not responsible for pricing, typographical, or other errors in any offer by us and reserve the right to cancel any orders resulting from such errors.

Prices. The price of the products and services are set forth in the quote specifically provided to you (if no quote was provided then the price is that set forth on our current price list or www.TASER.com). Prices do not include taxes, shipping, handling, insurance or other similar charges; any such charges will be added to the price or separately invoiced unless otherwise expressly indicated at the time of sale.

Payment Terms. Invoices are due and payable within the time period noted on your invoice, measured from the date of the invoice. We may invoice parts of an order separately. Where no credit has been granted to you or where credit has been withdrawn (in our absolute discretion) or for international sales, payment is required in full prior to shipment. Payment must be by credit card, wire transfer, or some other prearranged payment method. If we have reasonable grounds to believe that you will fail to comply with the payment terms or with the agreed credit terms, we are entitled to postpone or to refuse delivery of an order.

Taxes. Unless you provide us with a valid and correct tax exemption certificate applicable to your purchase and ship-to location, you are responsible for sales and other taxes associated with your order. **Shipping; Title; Risk of Loss.** We reserve the right to make partial shipments and products may ship from multiple locations. All shipments are FOB TASER's facility and title and risk of loss pass from us to you on upon delivery to the common carrier by TASER. You are responsible for all freight charges. Any loss or damage that occurs during shipment is your responsibility. Shipping dates are estimates only. Delivery is typically 2–6 weeks after receipt of order or payment.

Excusable delays. We will use commercially reasonable efforts to deliver all products and services ordered by you as soon as reasonably practicable. In the event of interruption of any delivery due to causes beyond our reasonable control, including but not limited to force majeure, fire, labor disturbances, riots, accidents, or inability to obtain necessary materials or components, we have the right, in our sole discretion and upon oral or written notice to you, to delay or terminate the delivery.

Not For Resale or Export. Shipping of some our products out of the United States is restricted by U.S. federal law and neither the product nor its technology can be exported out of the U.S. without a validated export license issued by the U.S. Department of Commerce and a signed BIS-711 on file with us.

Regulations and Restrictions. You agree to comply with all applicable laws, codes and license requirements, and controls of the United States and other applicable jurisdictions in connection with the use of TASER products and services including your acceptance of responsibility for the payment of any relevant taxes or duties. Please go to our website (www.TASER.com) or contact our Customer Service Department for a list of known regulations and restrictions regarding the sale, possession, and use of



Title: TASER International, Inc.'s Sales Terms and Conditions – Direct Sales to End User Purchasers

Department: Legal

Version: 6.0

Release Date: 11/22/2013

TASER CEW products. You are responsible for understanding and verifying all local laws, regulations, and restrictions.

Warranty Coverage. Our current warranty provisions, warranty exclusions, release, and any limitations of liability located at www.TASER.com are also applicable to your purchase.

Product Warnings. See our website at www.TASER.com for the most current product warnings.

Proprietary Information. You agree that we have and claim various proprietary rights in the hardware, firmware, software, and the integration of ancillary materials, knowledge, and designs that constitute our products and services, and that you will not directly or indirectly cause any proprietary rights to be violated.

Design Changes. We reserve the right to make changes in design of any of our products and services without incurring any obligation to notify you or to make the same change to products and services previously purchased.

Severable Provisions. If any provision of these Sales Terms and Conditions is found by a court of competent jurisdiction to be invalid or unenforceable, then the remainder will have their full force and effect and the invalid provision will be modified or partially enforced by the court to the maximum extent permitted by law to effectuate the purpose of this agreement.

No Assignment. You may not assign this agreement nor any related order and you may not delegate your duties under this agreement without our prior written consent which will not be unreasonably withheld. We may assign this agreement without your consent.

Entire Agreement. These Sales Terms and Conditions, along with the quote, sales order acknowledgement, and the applicable product warranty, license and service agreement(s), constitute the entire agreement between the parties. These Sales Terms and Conditions supersede and replace any prior agreement or understanding between the parties, including any oral representations concerning the subject matter of this agreement. Any prior or extrinsic representations or agreements, with the exception of the product warranty, any service and license agreement(s), are intended to be discharged or nullified.

Governing Law. The laws of the State of Arizona, U.S.A. govern this transaction and agreement, without regard to conflicts of law.

® and ™ are trademarks of TASER International, Inc., and TASER is a registered trademark of TASER International, Inc., registered in the U.S. All rights reserved. © 2013 TASER International, Inc.



TAP Term. The TAP Term start date is based upon the shipment date of the hardware covered under TAP. If the shipment of the hardware occurred in the first half of the month, then the Term starts on the 1st of the following month. If the shipment of the hardware occurred in the second half of the month, then the Term starts on the 15th of the following month.

TAP Termination. If an invoice for TAP is more than 30 days past due or your agency defaults on its payments for the

EVIDENCE.com services then Taser may terminate TAP and all outstanding AXON product related TAPs with your agency.

TASER will provide notification to you that TAP coverage is terminated. Once TAP coverage is terminated, then:

1. TAP coverage will terminate as of the date of termination and no refunds will be given.

2. TASER will not and has no obligation to provide the free Upgrade Models.

3. You will be invoiced for and are obligated to pay to TASER the MSRP then in effect for all Spare Products provided to you

under TAP. If the Spare Products are returned within 30 days of the Spare Product invoice date, credit will be issued and applied against the Spare Product invoice.

4. You will be responsible for payment of any missed payments due to the termination before being allowed to purchase any future TAP.

TAP Payment Terms. TAP may only be purchased at the point of sale. TASER will separately invoice you on an annual basis for the cost of TAP and you are responsible for payment within 30 days of the invoice (even if TASER does not receive an annual purchase order from you prior to issuing the invoice). The payment due date

Sales Terms. TASER's current Sales Terms and Conditions for Direct Sales to End User Purchasers, located at <http://www.taser.com/sales-terms-and-conditions>, are also applicable to your purchase.

No Assignment. You may not assign the TAP or any related order and you may not delegate your duties under these Terms without TASER's prior written consent, which will not be unreasonably withheld.

Entire Agreement. These Terms, along with the quote, sales order acknowledgement, Sales Terms and Conditions for Direct Sales to End User Purchasers, and the applicable product warranty, license and service agreements, constitute the entire agreement between the parties for the purchase of the AXON camera/ETM products and TAP. These Terms supersede and replace any prior agreement or understanding between the parties, including any oral representations concerning the subject matter of this agreement.

AXON flex and AXON body are trademarks of TASER International, Inc., and TASER and  are registered trademarks of TASER International, Inc., registered in the U.S. © 2014 TASER International, Inc. All rights reserved.

(Effective March 12, 2014)

Purchaser agrees to assume all risks of loss and all liability for any damages and personal injury which may result from the deployment, use, or misuse of the TASER product. TASER is not liable for the failure of the TASER product to perform and TASER is not liable for any claims made by a third party or by Purchaser for or on behalf of a third party.

Purchaser should update product software and/or firmware as they become available through TASER, as well as perform periodic data uploads to EVIDENCE.com services or download/backup copies of the information, data, and/or video contained on the TASER product storage media to protect the contents and as a precaution against possible operational failures.

To register your TASER product, please go to www.taser.com/register. Registration of your product allows TASER to contact you with important product notifications and provides a record in case of product loss or theft. Registration is voluntary and failure to register will not diminish your limited warranty rights.

Warranty Repair Procedure

This warranty supersedes any prior, contrary, or additional representations, whether written or oral. This warranty is TASER's only hardware warranty and may not be changed or enlarged by any agent, employee, distributor, dealer, or other person. This warranty, including any extended warranty, is non-transferable.

ACON 40v™, Shockwave™, Smart™, TASER CAM™, X2™, X25™, X26™, X-Rail™, TASER, ACON and  are registered trademarks of TASER International, Inc. and TASER is a trademark of TASER International, Inc. registered in the U.S. All rights reserved © 2014 TASER International, Inc.

Registration

The remedies provided for in the above warranty are expressly in lieu of any other liability TASER may have. TASER's cumulative liability to any party for any loss or damage resulting from any claims, demands, or actions arising out of or relating to any TASER product will not exceed the purchase price paid to TASER for the product. In no event will TASER be liable for any real, special, indirect, incidental, exemplary, punitive or consequential damages, however caused, whether for breach of warranty, breach of contract, negligence, strict liability, tort or under any other legal theory, even if TASER has been advised of the possibility of those damages or if those damages could have been reasonably foreseen, and notwithstanding any failure of essential purpose of any exclusive remedy provided in this warranty. Some local laws do not allow for the limitation or exclusion of liability for incidental or consequential damages, so the above limitation or exclusion may not apply to you. Any repair to or replacement of any product under this warranty may result in a loss of programs or data.

Release

Purchaser agrees to release TASER from any use, or misuse of the TASER product, including and all liability arising out of the deployment, without limitation, warranties of merchantability, design, fitness for a particular purpose, arising from a course of dealing, usage or trade practice, warranties against hidden or latent defects, and warranties against patent infringement. If statutory or implied warranties cannot be lawfully disclaimed, then all such warranties are limited to the duration of the express warranty described above and limited by the other provisions contained in this warranty document.

General

This warranty supersedes any prior, contrary, or additional representations, whether written or oral. This warranty is TASER's only hardware warranty and may not be changed or enlarged by any agent, employee, distributor, dealer, or other person. This warranty, including any extended warranty, is non-transferable.

ACON 40v™, Shockwave™, Smart™, TASER CAM™, X2™, X25™, X26™, X-Rail™, TASER, ACON and  are registered trademarks of TASER International, Inc. and TASER is a trademark of TASER International, Inc. registered in the U.S. All rights reserved © 2014 TASER International, Inc.



Part Number	Description	Unit of Measure	Unit Price
73002	AXON Body Camera	Each	\$ 401.00
73066	AXON Body Camera Full Solution Kit	Each	\$ 653.20
73075	Standard Uniform Clip Holster	Each	\$ 30.10
73076	Mini Alligator Clip Holster	Each	\$ 30.10
73077	Belt Clips Holster	Each	\$ 30.10
73078	Holster, 2-Bracket, HW	Each	\$ 30.10
73079	Holster, 2-Bracket, VELCRO	Each	\$ 30.10
73089	Pocket Mount Holster	Each	\$ 30.10
73090	AXON Flex Kit (Camera, Controller, Cable straight to right angle (73005), USB Sync Cable w/Wall Charger	Each	\$ 703.45
73061	AXON Flex Full Solution Kit	Each	\$ 1,018.62
73092	Motorola Moto G	Each	\$ 200.00
73094	Oakley Flak Jacket Kit Flex	Each	\$ 150.70
73026	6-bay + hub Evidence.com Dock	Each	\$ 1,502.48
70023	1-bay + hub Evidence.com Dock	Each	\$ 250.25
70028	Individual bay Evidence.com Dock	Each	\$ 250.25
70037	EXTENDED WARRANTY, 2 YEAR, EVIDENCE.COM DOCK, HUB	Each	\$ 499.95
70031	EXTENDED WARRANTY, 2 YEAR, EVIDENCE.COM DOCK, SINGLE BAY	Each	\$ 129.90
70030	EXTENDED WARRANTY, 2 YEAR, EVIDENCE.COM DOCK, 6 BAY	Each	\$ 79.95
73033	AXON Flex Kit 2-Year Extended Warranty	Each	\$ 299.95
73074	AXON Body Cam 2-Year Extended Warranty	Each	\$ 199.95
85035	Evidence.com Storage (GB)	Each	\$ 1.50
87001	Basic EVIDENCE.com License: 1 Year	Each	\$ 180.00
88001	Standard Evidence.com license: 1 Year	Each	\$ 300.00
89001	Pro Evidence.com license: 1 Year	Each	\$ 468.00
85078	Ultimate EVIDENCE.com annual payment	Each	\$ 660.00
85335	EVIDENCE.COM STORAGE (GB), 5-YEAR CONTRACT	Each	\$ 7.50
85054	TASER Assurance Plan AXON flex annual payment	Each	\$ 276.00
85070	TASER Assurance Plan AXON flex annual payment	Each	\$ 204.00
85079	TASER Assurance Plan EVIDENCE.com Dock Annual Payment (Based upon number of cameras purchased)	Each	\$ 36.00
85055	Premium Plus Package	Each	\$ 15,000.00
85056	Premium Package	Each	\$ 7,500.00
85014	A La Cart Package	Each	\$ 2,000.00
89005	Professional Evidence.COM License: YEAR 5 PAYMENT (Full Price)	Each	\$ 2,340.00
85045	5 YEAR PREPAID MAINTENANCE PLAN	Each	\$ 1,150.00
89101	Professional Evidence.COM License: YEAR 1 PAYMENT	Each	\$ 468.00
89201	Professional Evidence.COM License: YEAR 2 PAYMENT	Each	\$ 468.00
89301	Professional Evidence.COM License: YEAR 3 PAYMENT	Each	\$ 468.00
89401	Professional Evidence.COM License: YEAR 4 PAYMENT	Each	\$ 468.00
89501	Professional Evidence.COM License: YEAR 5 PAYMENT	Each	\$ 468.00
73004	USB Sync Cable w/ Wall Charger	Each	\$ 15.02
73008	Oakley Clip	Each	\$ 20.05
73009	Collar/Versatile/Cap Mount	Each	\$ 30.10
73088	Ratchet Collar/Versatile/Cap Mount	Each	\$ 30.10
73062	Ball Cap Mount	Each	\$ 30.10
73010	Low Rider Headband Flex	Each	\$ 50.20
73058	Low Rider Headband, Large, Flex	Each	\$ 55.22
73006	Controller Holster, Flex Standard Uniform Clip	Each	\$ 30.10
73035	Controller Holster, Flex, Mini Alligator Clip Flex	Each	\$ 30.10
73036	Controller Holster, Flex, Belt Clips, Flex	Each	\$ 30.10
73011	Equalette Mount	Each	\$ 20.05
73013	Helmet Mount	Each	\$ 20.05
73090	Helmet Mount, Ratchet, Shoni	Each	\$ 20.05
73091	Helmet Mount, Ratchet, HIC	Each	\$ 20.05
73020	Universal Magnet Clip	Each	\$ 7.99
73021	Multi-Mounting Kit, Flex (Low Rider Headband, Collar Mount, Equalette Mount, Oakley Kit)	Each	\$ 20.05
73059	Ballistic Vest Mount, Notating	Each	\$ 20.05
73088	Ratchet Collar/Versatile/Cap Mount	Each	\$ 30.10
73022	Cable, Straight to Right Angle 18"	Each	\$ 5.98
73005	Cable, Straight to Right Angle, 36"	Each	\$ 5.98
73023	Cable, Straight to Right Angle, 48"	Each	\$ 5.98
73025	Cable, Straight to Straight, 36"	Each	\$ 5.98
73026	Cable, Straight to Straight, 48"	Each	\$ 5.98
73027	Cable, Right Angle to Right Angle, 18"	Each	\$ 5.98
73028	Cable, Right Angle to Right Angle, 36"	Each	\$ 5.98
73029	Cable, Right Angle to Right Angle, 48"	Each	\$ 5.98
73060	Cable, Coiled, Straight to Right Angle 48"	Each	\$ 13.01
73081	TASER CAM HD/AXON Camera Universal Charger w/U.S. and International Adaptors	Each	\$ 15.02

*each day**

AXON Flex™ Camera Models	
Model	Model No.
AXON Flex Camera	73000 series
Color	Black

Specifications	
1. Operating temperature range: -4 °F to 122 °F [-20 °C to 50 °C]	1. Ambidextrous design for left- or right-side mounting.
2. Storage temperature range: ² -4 °F to 95 °F [-20 °C to 35 °C]	2. Multiple attachment options available, including: Oakley Flak Jacket® eyewear mount; Low Rider headband; Collar mount; Epaulette/shoulder mount; and Helmet mount.
3. 75° field of view camera lens	3. Playback via the AXON™ Mobile smart phone application or EVIDENCE Sync software.
4. Humidity: 80 percent non-condensing, when cable is attached	4. Several cable styles and cable lengths are available. ⁵
5. 30-second pre-event video buffer. Buffer does not include audio.	5. Configurable bit rate (multiple settings to optimize file size and upload speed)
6. Note: Buffer time can change depending on device state.	6. Full color audiovisual camera
7. 640 x 480 VGA video resolution	7. Retina Low-Light capability less than 1 lux
8. Up to 8 GB non-removable, solid state storage ³	8. Constructed from impact resistant polymer
9. Approximately 4 hours video storage under highest quality recording settings; up to 9 hours storage under medium quality recording settings; and up to 13 hours storage available at lowest quality recording setting.	9. Data is protected by TASER proprietary security features and can be viewed and downloaded with EVIDENCE.com services through the AXON Flex Evidence Transfer Manager (ETM) ⁶ and EVIDENCE Sync software.
10. Rechargeable Lithium-Ion Battery ⁴	10. Data download to personal computer through EVIDENCE Sync software is also available.
	11. GPS tagging and streaming capability available through Android™ and iPhone® AXON™ Mobile applications.

Physical Characteristics	
Length (L)	3.2 in [8.1 cm]
Height (H)	0.8 in [2.0 cm]
Width (W)	0.7 in [1.8 cm]
Weight	0.53 oz (15 g)

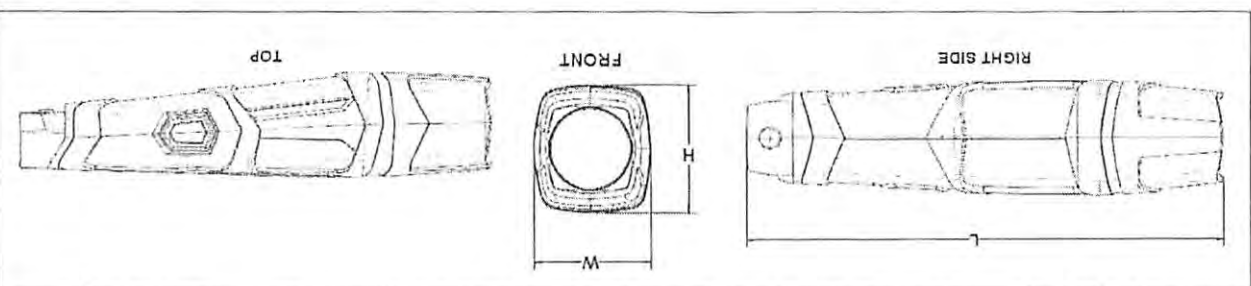

- Requires a cable connection to the AXON Flex Controller (model number 73001) to function.
- Less than 1 month at the high temperature. Long-term storage should be in a climate-controlled environment.
- Multi-Level Cell flash memory is rated for approximately 10,000 write cycles. The current technology along with normal usage, which includes recording and buffering and ETM sync processes, typically gives memory components a useful life of 4 to 5 years. A portion of the memory is reserved for the operating system.
- The AXON Flex camera contains a non-replaceable Lithium-Ion battery. Rechargeable Lithium-Ion batteries have a limited life of approximately 2 years, and will gradually lose their capacity to hold a charge. This loss of capacity (aging) is reversible. As the battery loses capacity, the length of time it will power your device (run time) decreases. Additionally, Lithium-Ion batteries continue to slowly discharge (self-discharge) when not in use or while in storage. It is advised that you routinely check the battery's charge status. The device should be recharged regularly to maintain the internal chemistry of the battery. TASER product user manuals summarize how to check battery status as well as battery charging instructions. The latest product manuals are available at www.TASER.com
- While all TASER products are thoroughly tested to ensure product reliability, all usage conditions cannot be anticipated. User checks are recommended to ensure connections remain snug and performance is unaffected. AXON Flex cables should be replaced at the first sign of wear or breakdown to ensure reliable function and use.
- User account and subscription required.
- Product specification may change without notice; actual product may vary from picture.
- Dimensions and weights are for reference only.



AXON Flex™ Controller Models	
Flex Controller ¹	Model No. 73001
	Color Black
Specifications	
1. Operating temperature range: -4° F to 122° F [-20° C to 50° C] ²	
2. Storage temperature range: ² -4° F to 95° F [-20° C to 35° C]	
3. Humidity: 80 percent non-condensing, with cable attached	
4. Lithium-ion rechargeable battery.	
5. 2500 mAh capacity. ^{3,4}	
6. Patents: U.S. and foreign patents pending.	
Over 12 hours' battery life under normal operation. ⁵	
Features	
1. EVENT button to start recording and return to buffering.	
2. On/Off slide switch to power the device. ⁶	
3. Battery button and LED to indicate remaining battery capacity.	
4. Operation LED on the top of the housing indicates device status.	
5. Several cable styles and cable lengths are available. ⁷	
6. Holster and several clip mounts are available.	
Physical Characteristics	
Dimensions	
Depth (D)	0.8 in [2.0 cm]
Width (W)	2.6 in [6.6 cm]
Height (H)	3.3 in [8.4 cm]
Weight	3.3 oz [94 g]

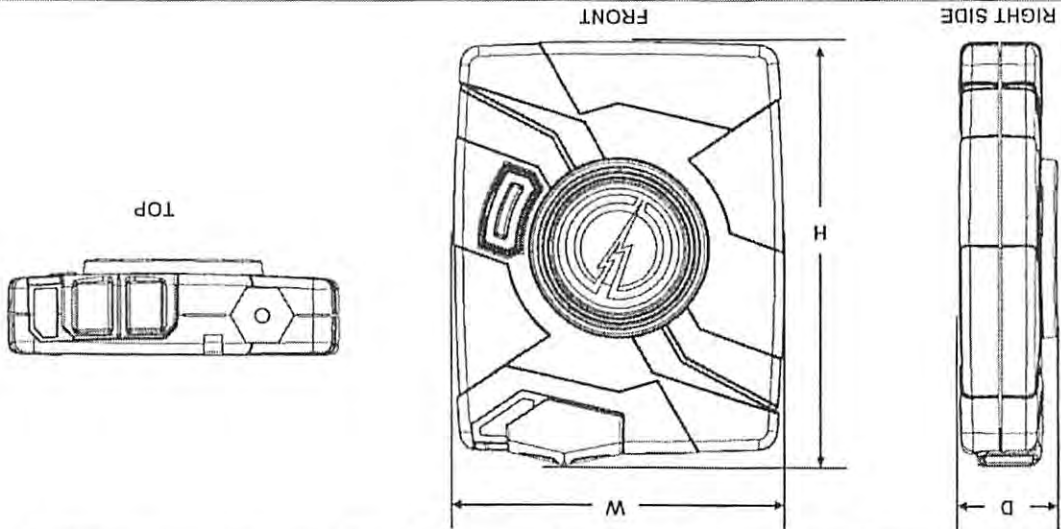

- 1 Requires cable connection to an AXON Flex Camera (model number 73000) for audio/video recording.
- 2 Less than 1 month at the high temperature. Long-term storage should be in a climate-controlled environment.
- 3 Rechargeable Lithium-ion batteries have a limited life of approximately 2 years or approximately 300 full charge and discharge cycles. With age, batteries will gradually lose their capacity to hold a charge. This loss of capacity (aging) is irreversible. As the battery loses capacity, the length of time it will power your device (run time) decreases. Additionally, lithium-ion batteries continue to slowly discharge (self-discharge) when not in use or while in storage. It is advised that you routinely check the battery's charge status. The device should be recharged regularly to maintain the internal chemistry of the battery. TASER product user manuals summarize how to check battery status as well as battery charging instructions.
- 4 The AXON Flex Controller cannot be disassembled. The internal battery is only replaceable as a complete assembly. Please contact www.TASER.com to purchase a replacement AXON Flex Controller.
- 5 Uses outside the above use profile, as well as temperature and other ambient conditions, can affect battery life.
- 6 The On/Off switch is magnetically activated. Close proximity with other magnets may cause the AXON Flex Controller to turn off or on.
- 7 While all TASER products are thoroughly tested to ensure product reliability, all usage conditions cannot be anticipated. User checks are recommended to ensure connections remain snug and performance is unaffected. AXON Flex cables should be replaced at the first sign of wear or breakdown to ensure reliable function and use.
- 8 Product specification may change without notice; actual product may vary from picture.
- 9 Dimensions and weights are for reference only.

AXON® EVIDENCE.com Dock Models	
Model	EVIDENCE.com Dock 6-Bay and Core ¹
Model No.	70026
Color	Black

Specifications²	
1. Input power requirements ³	Voltage: 15 V DC Current: 4 A DC Power: 60 W
2. Output specifications per port	Connector: Barrel power connector, inner diameter 0.08" [2.1 mm], outer diameter 0.22" [5.5 mm], length 0.37" [9.5 mm], inside positive
3. Operating Temperature: -4 °F [-20 °C] to 167 °F [75 °C]	Power: 2.75 W (maximum) Current: 500 mA (maximum) Voltage: 4.5 V DC to 5.5 V DC
4. Humidity: 85 percent non-condensing	
5. One USB B input port, twelve 2.5 mm dock output ports, one USB A 2.0 output port	
Characteristics^{2,4}	
1. Attaches to EVIDENCE.com Dock core to connect to the Internet.	
Physical Characteristics^{2,4}	
Width (W)	6.4" [16.2 cm]
Height (H)	2.18" [5.5 cm]
Depth (D)	11.25" [28.6 cm]
Weight	1.36 lb. [612.35 g]

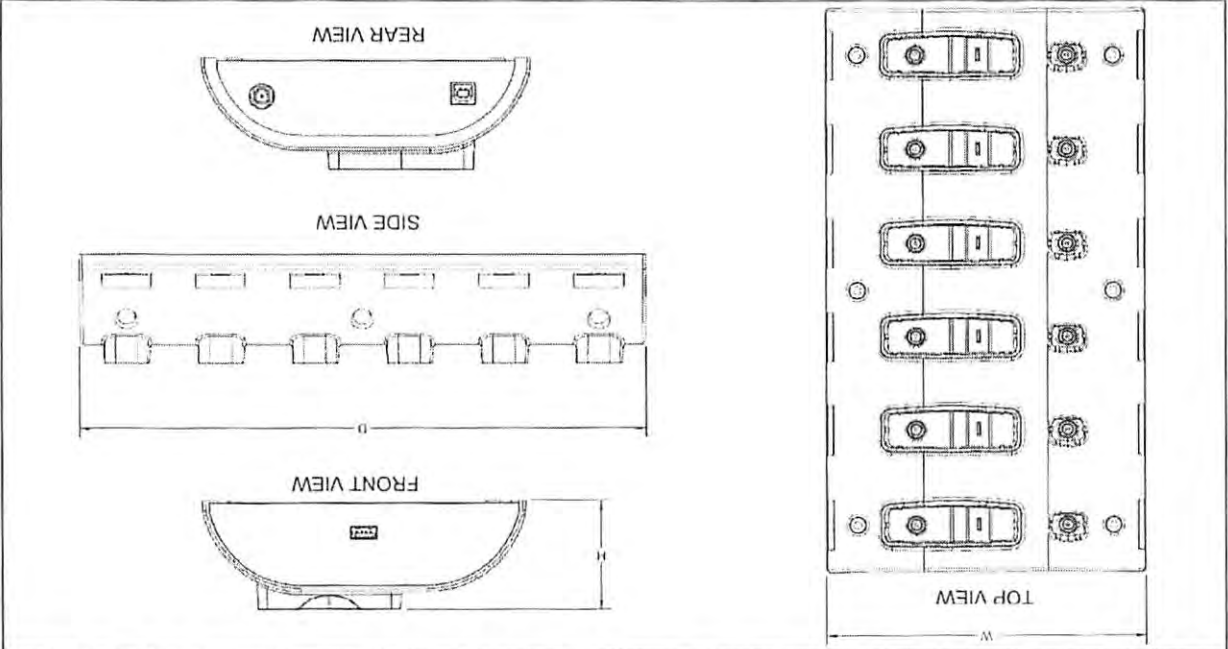

¹ This document only describes the bay. For information about the core, see the *TASER EVIDENCE.com Doc Core Specifications*.

² Product specification may change without notice; actual product may vary from picture.

³ Required AC service specifications for provided external AC-DC power supply are 100–240 V AC, 1.5 A (min), 50–60 Hz

⁴ Dimensions and weights are for reference only.

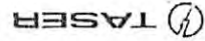



TASER International, Inc. ("TASER," "us," or "we") and ("Agency," "your," or "you") agree to accept and be bound by the following terms and conditions effective _____, 20____ ("Effective Date");

1. **Access Rights.** Upon the purchase or granting of a subscription from TASER and your opening of an Evidence.com account you will have access and use of the Evidence.com Services and Your Content during the subscription term ("Term"). You and each of your end users agree to adhere to this Agreement and all laws, rules, regulations, and policies applicable to your use of the Evidence.com Services. If you become aware of any violation of this Agreement by an end user, you will immediately terminate that end user's access to Your Content and the Evidence.com Services.

2. **You Own Your Content.** You control and own all right, title, and interest in and to Your Content and we obtain no rights to Your Content. You consent to your limited access to Your Content solely for the purpose of providing and supporting the Evidence.com Services to you and your end users. You represent that you own Your Content; and that none of Your Content or your end users' use of Your Content or the Evidence.com Services will violate this Agreement or applicable laws.

3. **Evidence.com Data Security.** We will implement commercially reasonable and appropriate measures designed to secure Your Content against accidental or unlawful loss, access or disclosure. We will maintain a comprehensive Information Security Program ("ISP") that includes logical and physical access management, vulnerability management, configuration management, incident monitoring and response, encryption of digital evidence you upload, security education, risk management, and data protection. You are responsible for maintaining the security of your end user names and passwords and taking steps to maintain appropriate security and access by your end users to Your Content. Log-in credentials are for your internal use only and you may not sell, transfer, or sublicense them to any other entity or person. You agree to be responsible for all activities undertaken by you, your employees, your contractors or agents, and your end users which result in unauthorized access to your account or Your Content. Audit log tracking for the video data is an automatic feature of the Services which provides details as to who accesses the video data and may be downloaded by you at any time. You will contact us immediately if you believe an unauthorized third party may be using your account or Your Content or if your account information is lost or stolen.

4. **Our Support.** We will make available to you updates as released by us to the Evidence.com Services. Updates may be provided electronically via the Internet. It is your responsibility to establish and maintain adequate access to the Internet in order to receive the updates. We will use reasonable efforts to continue supporting the previous version of any API or software for 6 months after the change (except if doing so (a) would pose a security or intellectual property issue, (b) is economically or technically burdensome, or (c) is needed to comply with the law or requests of governmental entities). You are responsible for maintaining the computer equipment and Internet connections necessary for your use of the Evidence.com Services.

5. **Data Privacy.** We will not disclose Your Content or any information about you except as compelled by a court or administrative body or required by any law or regulation. We will give you notice if any disclosure request is received for Your Content so you may file an objection with the court or administrative body. You agree to allow us access to certain information from you in order to: (a) perform troubleshooting services for your account at your request or as part of our regular diagnostic screenings; (b) enforce our agreements or policies governing your use of Evidence.com Services; or (c) perform analytic and diagnostic evaluations of the systems.

6. **Data Storage.** We will determine the locations of the data centers in which Your Content will be stored and accessible by your end users. For United States customers, we will ensure that all of Your Content stored in the Evidence.com Services remains within the United States including any backup data, replication sites, and disaster recovery sites. You consent to the transfer of Your Content to third parties for the purpose of storage of Your Content. Third party subcontractors responsible for storage of Your Content are contracted by us for data storage services. Ownership of Your Content remains with you.

7. **Fees and Payment.** Additional end users may be added during the Term at the pricing in effect at the time of purchase of additional end users, prorated for the duration of the Term. Additional end user accounts will terminate on the same date as the pre-existing subscriptions. You are responsible for paying all subscription fees and applicable taxes and duties for Evidence.com Services. Unless otherwise specified by us, all fees for Evidence.com Services are due and payable net 30 days for approved credit. Payment obligations are non-cancelable and fees paid are non-refundable and all amounts payable will be made without setoff, deduction, or withholding. We reserve the right to charge additional fees for you exceeding your purchased storage amounts or for TASER's assistance in the downloading or exporting of Your Content. We may charge you interest at the rate of 1.5% per month (or the highest rate permitted by law, if less) on all late payments. If a delinquent account is sent to collections, you are responsible for all collection and attorneys' fees.

8. **Suspension of Evidence.com Services.** We may suspend your or any end user's right to access or use any portion or all of the Evidence.com Services immediately upon notice to you if we determine:

- a. Your or an end user's use of or registration for the Evidence.com Services (i) poses a security risk to the Evidence.com Services or any third party, (ii) may adversely impact the Evidence.com Services or the systems or content of any other customer, (iii) may subject us, our affiliates, or any third party to liability, or (iv) may be fraudulent;
- b. You are, or any end user is, in breach of this Agreement, including if you are delinquent on your payment obligations for more than 30 days; or
- c. You have become the subject of any bankruptcy, reorganization, liquidation, dissolution, or similar proceeding;
- d. If we suspend your right to access or use any portion or all of the Evidence.com Services, you remain responsible for all fees and charges incurred through the date of suspension without any credits for any period of suspension. We will not delete any of Your Content on

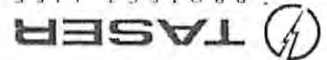

Evidence.com as a result of your suspension, except as specified elsewhere in this Agreement.

9. **Term.**

a. **Subscription Term.** The start date of the Term of this Agreement will be determined based upon the shipment date of any hardware

ordered as authorized by you in a signed Quote or purchase order and will remain in effect for the subscription Term agreed to in the Quote or

purchase agreement together with any renewal Terms until terminated as provided in this Agreement. If the hardware is shipped in the first half

of a month, then the Term starts on the 1st of the following month. If the hardware is shipped in the last half of a month, then the Term begins

on the 15th of the following month. If no hardware is purchased, then the Term will begin on the first of the month following the Effective Date of

the Agreement. This Agreement automatically renews for additional successive Terms of one (1) year each after the completion of your initial

Term at the list prices then in effect, unless you give us written notice of cancellation sixty (60) days prior to the end of a Term.

b. **Free Trial Term.** If you signed up for a free trial, you are granted a limited non-exclusive license to use the Evidence.com Services

for the term of the free trial period ("Trial Term"). Upon the expiration of the Trial Term you must purchase the Evidence.com Services to

continue to use the Evidence.com Services to access Your Content.

c. **Free EVIDENCE.com Lite Account.** If you signed up for a free Evidence.com Lite account, you are granted a limited non-exclusive

license to use the Evidence.com Lite Services. Your use of the Evidence.com Lite Services is not limited to a specific term and you may

cancel your Evidence.com Lite account and download Your Content at any time. Evidence.com Lite allows users to manage their conducted

electrical weapon (CEW) firing logs and TASER CAM data.

10. **Termination.**

a. **Termination for Convenience.** We may terminate this Agreement for any reason by providing you 30 days advance notice. In the

event that we terminate this Agreement under this Section we will issue you a refund of any prepaid amounts on a prorated basis.

b. **Termination for Cause.**

i. **By Either Party.** Either party may terminate this Agreement for cause upon 30 days advance notice to the other party if there is

any material default or breach of this Agreement by the other party, unless the defaulting party has cured the material default or

breach within the 30-day notice period. In the event that you terminate this Agreement under this Section and we failed to cure

the material breach or default, we will issue you a refund of any prepaid amounts on a prorated basis.

ii. **By Agency.** You are obligated to pay the fees under this Agreement as may lawfully be made from funds budgeted and

appropriated for that purpose during your then current fiscal year. In the event that sufficient funds will not be appropriated or

are not otherwise legally available to pay the fees required under this Agreement, this Agreement may be terminated by you.

You agree to deliver notice of termination under this Section 10(b)(ii) at least 90 days prior to the end of the then current fiscal

year.

c. **Effect of Termination.** Upon any termination of this Agreement: (a) all your rights under this Agreement immediately terminate; (b)

you remain responsible for all fees and charges you have incurred through the date of termination; and (c) Sections 2, 5-7, 11, 12 (except the

11. **Return of Your Content.**

a. **During the Term.** You can log into the Evidence.com Services to retrieve and manually download Your Content at any time during

the Term.

b. **After Termination.** We will not delete any of Your Content as a result of a termination during the 90 days following termination.

During this 90-day period you may retrieve Your Content only if you have paid all amounts due (there will be no application functionality of the

Evidence.com Services during this 90-day period other than the ability for you to retrieve Your Content). You will not incur any additional fees if

you download Your Content from the Evidence.com Services during this 90-day period. We have no obligation to maintain or provide any of

Your Content after the 90-day period and will thereafter, unless legally prohibited, delete all of Your Content stored in the Evidence.com

Services. Upon request, we will provide written proof that all of Your Content has been successfully deleted and fully removed from the

Evidence.com Services.

c. **Post-Termination Assistance.** We will provide you with the same post-termination data retrieval assistance that we generally make

available to all customers. Requests that we provide additional assistance to you in downloading or transferring Your Content will result in

additional fees from us and we will not warranty or guarantee data integrity or readability in the external system.

12. **IP Rights.** We or our licensors own and reserve all right, title, and interest in and to the Evidence.com Services and related software.

Subject to the terms of this Agreement, we grant you a limited, revocable, non-exclusive, non-sub licensable, non-transferable license to

access and use the Evidence.com Services solely in accordance with this Agreement during the Term. We own all right, title, and interest in

and to the Evidence.com Services, including without limitation all Intellectual Property Rights. If you or your end users provide any suggestions

to us for enhancements or improvements, we will own all right, title, and interest in and to the suggestions and have the right to use the

suggestions without restriction, even if you or your end users have designated the suggestions as confidential. You irrevocably assign to us all

right, title, and interest in and to the suggestions and agree to provide us any assistance we may require to document, perfect, and maintain

our rights in the suggestions.

13. **License Restrictions.** Neither you nor any of your end users may use the Evidence.com Services in any manner or for any purpose

other than as expressly permitted by this Agreement. Neither you nor any of your end users may, or attempt to: (a) permit any third party to

access the Evidence.com Services except as permitted in this Agreement; (b) modify, alter, lamp, repair, or otherwise create derivative



EVIDENCE.com Master Service Agreement

works of any of the Evidence.com Services; (c) reverse engineer, disassemble, or decompile the Evidence.com Services or apply any other process or procedure to derive the source code of any software included in the Evidence.com Services, or allow any others to do the same; (d) access or use the Evidence.com Services in a way intended to gain unauthorized access, avoid incurring fees or exceeding usage limits or quotas; (e) copy the Evidence.com Services in whole or part, except as expressly permitted in this Agreement; (f) use trade secret information contained in the Evidence.com Services, except as expressly permitted in this Agreement; (g) resell, rent, loan, or sublicense the Evidence.com Services; (h) access the Evidence.com Services in order to build a competitive product or service or copy any features, functions, or graphics of the Evidence.com Services; (i) remove, alter, or obscure any confidentially or proprietary rights notices (including copyright and trademark notices) of ours or our licensors on or within the Evidence.com Services or any copies of the Evidence.com Services; or (j) use the Evidence.com Services to store or transmit infringing, libelous, or otherwise unlawful or tortious material, to store or transmit material in violation of third-party privacy rights, or to store or transmit malicious code. All licenses granted to you in this Agreement are conditional on your continued compliance with this Agreement, and will immediately and automatically terminate if you do not comply with any term or condition of this Agreement. During and after the Term, you will not assert, nor will you authorize, assist, or encourage any third party to assert, against us or any of our affiliates, customers, business partners, or licensors, any patent infringement or other intellectual property infringement claim regarding any Evidence.com Services you have used. You may only use our trademarks in accordance with the TASER Trademark Use Guidelines (located at www.TASER.com).

14. Third-Party Products and Services. No purchase of third-party products or services is required to use the Evidence.com Services other than a computer and internet access. Any acquisition by you of third-party products or services and any exchange of data between you and any third-party provider, is solely between you and the applicable third-party provider. We do not warrant or support third-party products or services, whether or not they are designated by us as "certified" or otherwise, except as specified in a Quote. If you install or enable Third-Party Applications for use with Evidence.com Services, you acknowledge that we may need to allow providers of those Third-Party Applications to access Your Content as required for the interoperation of the Third-Party Applications with the Evidence.com Services. We are not responsible for any disclosure, modification or deletion of Your Content resulting from any access by Third-Party Application providers. **15. Representations by You.** You represent and warrant to us that: (a) you have been duly authorized by the laws of the applicable jurisdiction, and by a resolution of your governing body, if legally required, to execute and deliver this Agreement and to carry out your obligations under this Agreement; (b) all legal requirements have been met, and procedures have been followed, including public bidding, if legally required, in order to ensure the enforceability of this Agreement; (c) if you are a government agency, that the Evidence.com Services will be used by you only for essential governmental or proprietary functions consistent with the scope of your authority and will not be used in a trade or business of any person or entity, by the federal government or for any personal, family or household use; and (d) if you are a government agency, you have funds available to pay until the end of its current appropriation period, and you intend to request funds to make payments in each appropriation period, from now until the end of the Term.

16. Our Warranty. We warrant that the Evidence.com Services (a) will perform materially in accordance with the Documentation, (b) will be performed in a timely and professional manner by qualified persons with the technical skills, training, and experience to perform the Evidence.com Services, and (c) will not infringe or misappropriate any patent, copyright, trademark, or trade secret rights of any third party. All warranties or guarantees given or made by us with respect to the Evidence.com Services are solely for the benefit of you and your end users and are not transferable and are null and void if you breach any term or condition of this Agreement. THE EVIDENCE.COM SERVICES ARE PROVIDED "AS IS." WE AND OUR AFFILIATES AND LICENSORS MAKE NO REPRESENTATIONS OR WARRANTIES OF ANY KIND, WHETHER EXPRESS, IMPLIED, STATUTORY OR OTHERWISE THAT THE EVIDENCE.COM SERVICES OR THIRD-PARTY CONTENT WILL BE UNINTERRUPTED, ERROR FREE OR FREE OF HARMFUL COMPONENTS, OR THAT ANY CONTENT, INCLUDING YOUR CONTENT OR THE THIRD-PARTY CONTENT, WILL BE SECURE OR NOT OTHERWISE LOST OR DAMAGED, OR THAT THE EVIDENCE.COM SERVICES WILL MEET YOUR REQUIREMENTS. EXCEPT AS PROVIDED IN THIS SECTION 16, TO THE EXTENT PROHIBITED BY LAW, WE AND OUR AFFILIATES AND LICENSORS DISCLAIM ALL WARRANTIES, INCLUDING ANY IMPLIED WARRANTIES OF MERCHANTABILITY, SATISFACTORY QUALITY, FITNESS FOR A PARTICULAR PURPOSE, NON-INFRINGEMENT, OR QUIET ENJOYMENT, AND ANY WARRANTIES ARISING OUT OF ANY COURSE OF DEALING OR USAGE OF TRADE. YOU ARE SOLELY RESPONSIBLE FOR ENSURING THAT YOUR USE OF THE EVIDENCE.COM SERVICES IS IN ACCORDANCE WITH APPLICABLE LAW. YOU ARE SOLELY RESPONSIBLE FOR: (A) ALL DATA BEFORE IT IS UPLOADED TO THE EVIDENCE.COM SERVICES; (B) CONFIGURING AND SETTING UP ANY HARDWARE OR NETWORKS THAT YOU CONNECT TO THE EVIDENCE.COM SERVICES; (C) YOUR NETWORKS AND HOW THEY MAY INTERACT WITH THE HARDWARE, SOFTWARE, OR EVIDENCE.COM SERVICES; AND (D) ANY SECURITY SETTINGS YOU ESTABLISH TO INTERACT WITH OR ON THE EVIDENCE.COM SERVICES. WE DISCLAIM ANY WARRANTIES OR RESPONSIBILITY FOR DATA CORRUPTION OR ERRORS BEFORE THE DATA IS UPLOADED TO THE EVIDENCE.COM SERVICES.

17. Indemnification and Hold Harmless. This Section states a party's sole liability to, and the party's exclusive remedy against, the other party for any type of claim specified below.

a. Indemnification by Us. We will defend, indemnify, and hold you harmless, and each of our respective employees, officers, directors, and representatives from and against any claims, damages, losses, liabilities, costs, and expenses (including reasonable attorneys' fees) arising out of or relating to any: (a) acts or omissions of us or our subcontractors or anyone directly or indirectly employed by any of them

Version 6.0
Department: Legal
The EVIDENCE.com Master Service Agreement
Release Date: 5/25/2014



or anyone for whose acts arising out of or related to this Agreement any of them may be liable, save and except for damage or injury caused solely by the negligence of you or your agents, officers, or employees; and (b) third-party claim alleging that the use of the Evidence.com Services as permitted under this Agreement infringes or misappropriates the intellectual property rights of a third party. You must provide us with prompt written notice of each such claim, tender to us the defense or settlement of each such claim at our expense, and cooperate fully with us in the defense or settlement of each such claim. If we receive notice of an alleged infringement, or if you use of the Evidence.com Services will be prevented by permanent injunction, we may, at our sole option and expense, procure for you the right to continue using the Evidence.com Services as provided in this Agreement, modify the Evidence.com Services so that it no longer infringes, replace the Evidence.com Services with other services of equal or superior functional capability, refund to you all amounts paid by you to us under this Agreement for the Evidence.com Services in the 1-year period immediately preceding the first event giving rise to the claim of infringement, or in the case of trademark infringement, instruct you to use an alternative trademark. We have no liability to you or any third party if any alleged infringement or claim of infringement is to any extent based upon: (a) any modification of the Evidence.com Services by you or any third party not approved by us; (b) use of the Evidence.com Services in connection with equipment, devices, or services not approved or recommended by us; (c) the use of Evidence.com Services other than as permitted under this Agreement or in a manner for which it was not intended; or (d) the use of other than the most current release or version of any software provided by us as part of or in connection with the Evidence.com Services. Nothing in this Section will affect any warranties in favor of you that are otherwise provided in or arise out of this Agreement.

b. Hold Harmless by You. To the extent permitted by your jurisdiction's local law, you will hold harmless us, our affiliates and licensors, and each of their respective employees, officers, directors, and representatives from and against any claims, damages, losses, liabilities, costs, and expenses (including reasonable attorneys' fees) arising out of or relating to any third-party claim concerning: (a) your or any of your end users' use of the Evidence.com Services (including any activities under your account and use by your employees and agents); (b) breach of this Agreement or violation of applicable law by you or any of your end users; (c) Your Content or the combination of Your Content with other applications, content or processes, including any claim involving alleged infringement or misappropriation of third-party rights by Your Content or by the use of Your Content; (d) a dispute between you and any of your end users; or (e) a dispute between you and any third-party over your collection or use of Your Content. You agree to maintain insurance coverage up to the amount allowed by State and local laws and regulations that would cover any claims, damages, losses, liabilities, costs, and expenses (including reasonable attorneys' fees) arising out of or related to any third-party claim in this section 17(b).

18. Limitations of Liability. WE AND OUR AFFILIATES OR LICENSORS WILL NOT BE LIABLE TO YOU FOR ANY DIRECT, INDIRECT, INCIDENTAL, SPECIAL, CONSEQUENTIAL OR EXEMPLARY DAMAGES (INCLUDING DAMAGES FOR LOSS OF PROFITS, GOODWILL, USE, OR DATA), EVEN IF A PARTY HAS BEEN ADVISED OF THE POSSIBILITY OF SUCH DAMAGES. FURTHER, NEITHER WE NOR ANY OF OUR AFFILIATES OR LICENSORS WILL BE RESPONSIBLE FOR ANY COMPENSATION, REIMBURSEMENT, OR DAMAGES ARISING IN CONNECTION WITH: (A) YOUR INABILITY TO USE THE EVIDENCE.COM SERVICES, INCLUDING AS A RESULT OF ANY (I) TERMINATION OR SUSPENSION OF THIS AGREEMENT OR YOUR USE OF OR ACCESS TO THE EVIDENCE.COM SERVICES, (II) OUR DISCONTINUATION OF ANY OR ALL OF THE EVIDENCE.COM SERVICES, OR, (III) WITHOUT LIMITING ANY OTHER OBLIGATIONS, ANY UNANTICIPATED OR UNSCHEDULED DOWNTIME OF ALL OR A PORTION OF THE EVIDENCE.COM SERVICES FOR ANY REASON, INCLUDING AS A RESULT OF POWER OUTAGES, SYSTEM FAILURES OR OTHER INTERRUPTIONS; (B) THE COST OF PROCUREMENT OF SUBSTITUTE GOODS OR SERVICES; (C) ANY INVESTMENTS, EXPENDITURES, OR COMMITMENTS BY YOU IN CONNECTION WITH THIS AGREEMENT OR YOUR USE OF OR ACCESS TO THE EVIDENCE.COM SERVICES; OR (D) ANY UNAUTHORIZED ACCESS TO, ALTERATION OF, OR THE DELETION, DESTRUCTION, DAMAGE, LOSS OR FAILURE TO STORE ANY OF YOUR CONTENT OR OTHER DATA. IN ANY CASE, WHETHER IN CONTRACT, TORT OR UNDER ANY OTHER THEORY OF LIABILITY, OUR AND OUR AFFILIATES' AND LICENSORS' AGGREGATE LIABILITY UNDER THIS AGREEMENT WILL BE LIMITED TO THE GREATER OF \$100,000 OR THE AMOUNT YOU ACTUALLY PAY US UNDER THIS AGREEMENT FOR THE EVIDENCE.COM SERVICES THAT GAVE RISE TO THE CLAIM DURING THE 12 MONTHS PRECEDING THE CLAIM.

19. Miscellaneous
a. Definitions.

- i.** "Evidence.com Services" means our web services for Evidence.com, the EVIDENCE.com site, EVIDENCE Sync software, EVIDENCE Mobile App, AXON@ Mobile App, other software, maintenance, storage, and any other product or service provided by us under this Agreement. This does not include any Third-Party Applications, hardware warranties, or the my.evidence.com services.
- ii.** "Your Content" means software, data, text, audio, video, images or other content you or any of your end users (a) run on the Evidence.com Services, (b) cause to interface with the Evidence.com Services, or (c) upload to the Evidence.com Services under your account or otherwise transfer, process, use or store in connection with your account.
- iii.** "Documentation" means the user guides, quick reference guides, and other technical and operations manuals and specifications for the Evidence.com Services provided by us, as that documentation may be updated by us from time to time.
- iv.** "Confidential Information" means all nonpublic information disclosed by us, our affiliates, business partners or our or their respective employees, contractors or agents that is designated as confidential or that, given the nature of the information or circumstances surrounding its disclosure, reasonably should be understood to be confidential. Confidential information includes:



(a) nonpublic information relating to our or our affiliates or business partners' technology, customers, business plans, promotional and marketing activities, finances and other business affairs; (b) third-party information that we are obligated to keep confidential; and (c) the nature, content and existence of any discussions or negotiations between you and us or our affiliates that is not subject to your public record laws. Confidential information does not include any information that: (i) is or becomes publicly available without breach of this Agreement; (ii) can be shown by documentation to have been known to you at the time of your receipt from us; (iii) is received from a third party who did not acquire or disclose the same by a wrongful or tortious act; or (iv) can be shown by documentation to have been independently developed by you without reference to the Confidential Information.

v. "Policies" means any Service Level Agreement, the Trademark Use Guidelines, all restrictions described on the Evidence.com site, and any other policy or terms referenced in or incorporated into this Agreement. Policies do not include whitepapers or other marketing materials.

b. Confidentiality. Any party may use the other party's Confidential Information only as permitted under this Agreement. Except as required by applicable law or judicial order, you will not disclose our Confidential Information during the Term or at any time during the 5-year period following the end of the Term. You will take all reasonable measures to avoid disclosure, dissemination or unauthorized use of our Confidential Information.

c. Force Majeure. Neither party will be liable for any delay or failure to perform any obligation under this Agreement where the delay or failure results from any cause beyond the parties' reasonable control, including acts of God, labor disputes or other industrial disturbances, systemic electrical, telecommunications, or other utility failures, earthquakes, storms or other elements of nature, blockages, embargoes, riots, acts or orders of government, acts of terrorism, or war.

d. Independent Contractors. The parties are independent contractors, and neither party, nor any of their respective affiliates, is an agent of the other for any purpose or has the authority to bind the other. This Agreement does not create a partnership, franchise, joint venture, agency, fiduciary, or employment relationship between the parties.

e. No Third-Party Beneficiaries. This Agreement does not create any third-party beneficiary rights in any individual or entity that is not a party to this Agreement.

f. Non-discrimination and Equal Opportunity. During the performance of this Agreement, we agree that neither we nor our employees will discriminate against any person, whether employed by us or otherwise, on the basis of race, color, religion, gender, age, national origin, handicap, marital status, or political affiliation or belief. In all solicitations or advertisements for employees, agents, subcontractors or others to be engaged by us or placed by or on behalf of us, we will state all qualified applicants will receive consideration for employment without regard to race, color, religion, gender, age, national origin, handicap, marital status, or political affiliation or belief.

g. U.S. Government Rights. The Evidence.com Services are provided to the U.S. Government as "commercial items," "commercial computer software," "commercial documentation," and "technical data" with the same rights and restrictions generally applicable to the Evidence.com Services. If you are using the Evidence.com Services on behalf of the U.S. Government and these terms fail to meet the U.S. Government's needs or are inconsistent in any respect with federal law, you will immediately discontinue your use of the Evidence.com Services. The terms "commercial item," "commercial computer software," "commercial documentation," and "technical data" are defined in the Federal Acquisition Regulation and the Defense Federal Acquisition Regulation Supplement.

h. Import and Export Compliance. In connection with this Agreement, each party will comply with all applicable import, re-import, export, and re-export control laws and regulations, including the Export Administration Regulations, the International Traffic in Arms Regulations, and country-specific economic sanctions programs implemented by the U.S. Office of Foreign Assets Control. You are solely responsible for compliance related to the manner in which you choose to use the Evidence.com Services, including your transfer and processing of Your Content, the provision of Your Content to end users, and the region in which any of the foregoing occur.

i. Assignment. Neither party may assign or otherwise transfer this Agreement or any of its rights and obligations under this Agreement without the prior written approval of the other party, except that we may assign or otherwise transfer this Agreement or any of our rights or obligations under this Agreement without your consent (a) for financing purposes, (b) in connection with a merger, acquisition or sale of all or substantially all of our assets, (c) to a subsidiary corporation, or (d) to a subsidiary corporation. Subject to the foregoing, this Agreement will be binding upon, and inure to the benefit of the parties and their respective successors and assigns.

j. No Waivers. The failure by either party to enforce any provision of this Agreement will not constitute a present or future waiver of the provision nor limit the party's right to enforce the provision at a later time. All waivers by a party must be in writing and sent in accordance with this Agreement to be effective.

k. Severability. This Agreement is contractual and not a mere recital. If any portion of this Agreement is held to be invalid or unenforceable, the remaining portions of this Agreement will remain in full force and effect. Any invalid or unenforceable portions will be interpreted to effect and intent of the original portion. If such construction is not possible, the invalid or unenforceable portion will be severed from this Agreement but the rest of the Agreement will remain in full force and effect.

l. Governing Law; Venue. The laws of the state where you are physically located, without reference to conflict of law rules, govern this Agreement and any dispute of any sort that might arise between the parties. The United Nations Convention for the International Sale of Goods does not apply to this Agreement.

m. Litigation Costs. In the event of any legal action to enforce the provisions of this Agreement, the successful party in enforcing any



EVIDENCE.com Master Service Agreement

provision of this Agreement will be awarded that party's reasonable attorneys' fees and costs.

n. **Notices.** All communications and notices to be made or given pursuant to this Agreement must be in the English language. To You, We may provide any notice to you under this Agreement by: (i) posting a notice on your specific agency EVIDENCE.com site; or (ii) sending a message to the email address(es) then associated with your account. Notices we provide by posting on your EVIDENCE.com site will be effective upon posting and notices we provide by email will be effective when we send the email. You will be deemed to have received any email sent to the email address then associated with your account when we send the email, whether or not you actually receive the email.

ii. **To Us.** To give us notice under this Agreement, you must contact us: (i) by email transmission to evidencecontracts@taser.com; or (ii) by personal delivery, overnight courier or registered or certified mail to TASER International, Inc., ATTN: Evidence Contracts, 17800 N. 85th Street, Scottsdale, Arizona 85255. We may update the email or address for notices to us by posting a notice on your Evidence.com site. Notices provided by personal delivery will be effective immediately. Notices provided by email transmission or overnight courier will be effective one business day after they are sent. Notices provided registered or certified mail will be effective 3 business days after they are sent.

o. **Entire Agreement.** This Agreement, including the Policies and the Quote provided by TASER, is the entire agreement between you and TASER regarding the Evidence.com Services. This Agreement supersedes all prior or contemporaneous representations, understandings, agreements, or communications between you and TASER, whether written or verbal, regarding the subject matter of this Agreement. You agree that your purchases are neither contingent on the delivery of any future functionality or features nor dependent on any oral or written public comments made by us regarding future functionality or features of the Evidence.com Services. We will not be bound by, and specifically object to, any term, condition or other provision which is different from or in addition to the provisions of this Agreement (whether or not it would materially alter this Agreement) and which is submitted by you in any order, receipt, acceptance, confirmation, correspondence or other document. No modification or amendment of any portion of this Agreement will be effective unless in writing and signed by the parties to this Agreement. If we provide a translation of the English language version of this Agreement, the English language version of the Agreement will control if there is any conflict.

p. **Voluntary Agreement.** This Agreement was negotiated and executed voluntarily and is not the result of duress, fraud, undue influence or any threat of any kind. All parties had the opportunity to read and consider this Agreement, to consult with counsel, and fully understand the Agreement.

q. **Time is of the Essence.** Time is of the essence in connection with all matters and obligations pertaining to this Agreement. **r. Counterparts.** If this Agreement from requires the signatures of the parties, then this Agreement may be executed in any number of counterparts, each of which will be considered an original for all purposes, and all of which, when taken together, constitute one and the same Agreement.

TASER International, Inc.		Agency Name:	
By: _____	By: _____	Name: _____	Name: _____
Title: _____	Title: _____	Title: _____	Title: _____
Signature _____	Signature _____	Signature Date: _____	Signature Date: _____
Date: _____	Date: _____	Address: _____	
17800 N. 85th Street		Address: _____	
Scottsdale, AZ 85255		Address: _____	
Attn: General Counsel		Address: _____	
Email: legal@taser.com		Address: _____	

[Document revised 6-25-2014]

Project Life and (TM) are trademarks of TASER International, Inc., and TASER and AXON are registered trademarks of TASER International, Inc., registered in the U.S. All rights reserved. © 2014 TASER International, Inc.

BY ORDERING OR ACCEPTING PROFESSIONAL SERVICES FROM TASER INTERNATIONAL, INC. (TASER) YOU AGREE THAT YOU HAVE READ AND UNDERSTAND THIS AGREEMENT AND YOU ACCEPT AND AGREE TO BE BOUND BY THE FOLLOWING TERMS AND CONDITIONS. You represent to us that you are lawfully able to enter into contracts and if you are entering into this Agreement for an entity, such as the company, municipality, or government agency you work for, you represent to us that you have legal authority to bind that entity. If you do not have this authority, do not order or accept the Professional Services. In consideration of the mutual promises contained in this Agreement, the parties agree to all terms of the Agreement effective as of the date you signed the Quote or submit your purchase order, whichever is first (**Effective Date**).

Terms and Conditions

This Professional Services Agreement (**Agreement**) is an agreement between TASER International, Inc. (TASER, **we, us, or our**) and you or the entity you represent (**Agency or you**). This Agreement contains the terms and conditions that govern our provision of Professional Services to you for assistance in deploying and implementing TASER camera systems and EVIDENCE.com service solutions. See Section 17 for definitions of certain capitalized terms used in this Agreement.

1. **Term and Pricing.**
 - a. **Term.** The term of this Agreement commences on the Effective Date. The actual work to be performed by us is not authorized to begin until we receive the signed Quote or your purchase order, whichever is first.
 - b. **Service Pricing.** All Services performed by us will be rendered in accordance with the fees set forth in the Quote. You will pay us in accordance with the terms contained in this Agreement unless different payment terms have been identified and agreed upon in the Quote.
 - c. **Taxes.** You are responsible for any sales or use taxes assessed on payment for Services and Products. We will itemize sales or use taxes separately on our invoices. We are responsible for all other taxes, duties and fees. If you are exempt from taxation for the Services or Products, you must submit an exemption certificate to us.
2. **Invoicing and Payment Terms.**
 - a. **Services.** We will invoice you, in accordance with this Agreement, for all Services provided. Notwithstanding the foregoing, no terms, provisions, or conditions of any purchase order or other business form or written authorization used by you will have any effect on, or otherwise modify, the rights, duties, or obligations of the parties under this Agreement, regardless of any failure of us to object to such terms, provisions, or conditions.
 - b. **Payment.** All payments for fees and expenses are due 30 days after the date of invoice. Interest at the rate of 1.5% per month (or the highest rate permitted by law, if less) may be charged on all late payments. Payment obligations are non-cancelable and amounts paid are non-refundable. All amounts payable under this Agreement will be made without setoff or counterclaim, and without any deduction or withholding. Amounts pre-paid for Services will expire within 6 months of the Effective Date; therefore all Services must be completed within that time period. Any delays by you may result in additional fees due to us, and delay in our completion of the Services.
3. **Scope of Services.** The project scope will consist of the Services identified on your Quote. The Premium Plus Service Package and Premium Service Package are detailed below:

Description of the Service Packages		
Premium Plus Services	Premium Plus Services	Premium Services
System set up and configuration Setup AXON® Mobile on smart phones (if applicable) Configure categories & custom roles based on Agency need Troubleshoot IT issues with EVIDENCE.com and evidence transfer manager (ETM) access Work with IT to install EVIDENCE Sync software on locked-down computers (if applicable)	1 on-site session	virtual assistance
ETM installation	on-site assistance	virtual assistance



Description of the Service Packages	
Premium Plus Services	Premium Services

	<p>Work with Agency to decide ideal location of ETM setup and set configurations on ETM if necessary</p> <p>Authenticate ETM with EVIDENCE.com using "admin" credentials</p> <p>Work with Agency's IT to configure its network to allow for maximum bandwidth and proper operation within Agency's network environment</p>		
	<p>Dedicated Project Manager</p> <p>Assignment of a specific TASER representative for all aspects of planning the Product rollout (Project Manager). Ideally, the Project Manager will be assigned to the Agency 4-6 weeks prior to rollout.</p>		
	<p>Weekly project planning meetings</p> <p>Project Manager will develop a Microsoft Project plan for the rollout of AXON camera units, ETMs and EVIDENCE.com account training based on size, timing of rollout and Agency's desired level of training. Up to 4 weekly meetings leading up to the ETM installation of not more than 30 minutes in length.</p>		
	<p>Best practice implementation planning session—1 on-site session to:</p> <p>Provide considerations for establishment of video policy and system operations best practices based on TASER's observations with other agencies</p> <p>Discuss importance of entering metadata in the field for organization purposes and other best practice for digital data management</p> <p>Provide referrals to other agencies using the AXON camera products and EVIDENCE.com services</p> <p>Create project plan for larger deployments</p> <p>Recommend rollout plan based on review of shift schedules</p>		
	<p>System Admin and troubleshooting training sessions</p> <p>2 on-site sessions—each providing a step-by-step explanation and assistance for Agency's configuration of security, roles & permissions, categories & retention, and other specific settings for EVIDENCE.com.</p>		
	<p>AXON instructor training</p> <p>Prior to general user training on AXON camera systems and EVIDENCE.com services, TASER's on-site professional services team will provide training with the goal of certifying instructors who can support the Agency's subsequent AXON camera and EVIDENCE.com training needs.</p>	training for up to 5 individuals at the Agency	training for up to 2 individuals at the Agency
	<p>End user go live training and support sessions</p> <p>Provide individual device set up and configuration assistance; pairing with viewers when applicable; and training on device use, EVIDENCE.com and EVIDENCE Sync.</p>	6 on-site sessions	3 on-site sessions
	<p>Implementation document packet</p> <p>EVIDENCE.com administrator guides, camera implementation guides, network setup guide, sample policies, and categories & roles guide</p>		virtual assistance
	<p>Post go live review session</p>	on-site assistance	

4. Out of Scope Services. We are responsible to perform only the Services described on your Quote. Any

additional services discussed or implied that are not defined explicitly by the Quote will be considered out of the scope.

5. Delivery of Services.

a. Hours and Travel. Our personnel will work within normal business hours, Monday through Friday, 8:30 a.m. to 5:30 p.m., except holidays unless otherwise agreed in advance. All tasks on-site will be performed over a consecutive timeframe unless otherwise agreed to by the parties in advance. Travel time by our personnel to your premises will not be charged as work hours performed.

b. Changes to Services. Changes to the scope of Services must be documented and agreed upon by the parties in a change order. If the changes cause an increase or decrease in any charges or cause a scheduling change from that originally agreed upon, an equitable adjustment in the charges or schedule will be agreed upon by the parties and included in the change order, signed by both parties.

c. Delays. If any delays are caused by you, you will be responsible for any costs incurred by us in preparing for the performance of the Services, and we will be entitled to recover these costs from you, including travel related costs. The non-performance or delay by us of our obligations under this Agreement will be excused if and to the extent the non-performance or delay results directly from the failure by you to perform your responsibilities. If any failure or delay by you to perform any of your responsibilities prevents or delays our performance of our obligations under this Agreement, we will be entitled to a reasonable extension of time to the applicable performance dates to reflect the extent of the impact of the failure or delay by you.

d. Performance Warranty. We warrant that we will perform the Services in a good and workmanlike manner. In the event the Services do not meet the requirements and specifications agreed upon, you must provide us with written notice and details of the alleged non-complying Services within 7 calendar days after completion of the Services involved. After determination by us that the Services were not in conformance to the requirements and specifications, we will re-perform the non-complying Services at no additional cost.

6. Your Responsibilities. Our successful performance of the Services depends upon your:

- a.** Making available your relevant systems for assessment by us prior to our arrival at the Installation Site;
- b.** Ensuring that prior to our arrival at the Installation Site that your network and systems comply with the following system requirements posted at <http://www.laser.com/products/digital-evidence-management/evidence/>;
- c.** Making any required modifications, upgrades or alterations to your hardware, facilities, systems and networks related to our performance of the Services prior to our arrival at the Installation Site;
- d.** Providing access to the building facilities and where we are to perform the Services, subject to safety and security restrictions imposed by you (including providing security passes or other necessary documentation to our representatives performing the Services permitting them to enter and exit your premises with laptop personal computers and any other materials needed to perform the Services);
- e.** Providing suitable workspace with telephone and Internet access for our personnel while working at the Installation Site and in your facilities;
- f.** Timely implementation of operating procedures, audit controls, and other procedures necessary for your intended use of the Products;
- g.** Providing all necessary infrastructure information (TCP/IP addresses, node names and network configuration) necessary for us to provide the Services;
- h.** Promptly installing and implementing any and all software updates provided by us;
- i.** Ensuring that all appropriate data backups are performed;
- j.** Providing to us the assistance, participation, review and approvals and participating in testing of the Products as requested by us;
- k.** Providing us with remote access to your EVIDENCE.com account when required for us to perform the Services;
- l.** Designating a representative who will be the main point of contact for all communication with us and who has the authority to act on your behalf in matters regarding the performance of the Services;
- m.** Ensuring the reasonable availability by phone or pager or knowledgeable staff and personnel, system administrators and operators to provide timely, accurate, complete and up-to-date documentation and information for the duration of the Term (these contacts are to provide background information and clarification of information required to perform the Services);
- n.** Instructing your personnel so that they are, at all times, educated and trained in the proper use and





operation of the Products and that the Products are used in accordance with applicable TASER manuals and instructions; and

o. Identifying in advance any holidays, non-work days, or major events that may impact the project.

7. Authorization to Access Computer Systems to Perform Services. You authorize us to access your relevant computers and network systems solely for the purpose of performing the Services. We will work diligently to identify as soon as reasonably practicable the resources and information we expect to use, and will provide an initial itemized list to you. You are responsible for, and assume the risk of any problems, delays, losses, claims, or expenses resulting from the content, accuracy, completeness, and consistency of all data, materials, and information supplied by you.

8. Site Preparation and Installation. Prior to delivering any Services, we will provide you with 1 copy of the then-current user documentation for the Services and related Products in paper or electronic form (**Product User Documentation**). The Product User Documentation will include all environmental specifications that must be met in order for the Services and related Products to operate in accordance with the Product User Documentation. Prior to the installation of Product (whether performed by you or TASER), you must prepare the installation Site in accordance with the environmental specifications set forth in the Product User Documentation. Following the installation of the Products, you must maintain the installation Site where the Products have been installed in accordance with the environmental specifications set forth in the Product User Documentation. In the event that there are any updates or modifications to the Product User Documentation for any Products provided by us under this Agreement, including the environmental specifications for the Products, we will provide the updates or modifications to you when they are generally released by us to our customers.

9. Acceptance Checklist. We will present you with an Acceptance Checklist (Checklist) upon our completion of the Services. You will sign the Checklist acknowledging completion of the Services once the on-site service session has been completed. If you reasonably believe that we did not complete the Services in substantial conformance with this Agreement, you must notify us in writing of your specific reasons for rejection of the Services within 7 calendar days from delivery of the Checklist to you. We will address your issues and then will re-present the Checklist for your approval and signature. If we do not receive the signed Checklist or a written notification of the reasons for the rejection of the performance of the Services from you within 7 calendar days of delivery of the Checklist to you, the absence of your response will constitute your affirmative acceptance of the Services, and a waiver of any right of rejection.

10. Liability for Loss or Corruption of Data. The parties' default obligations concerning the liability for any loss or corruption of data under this Agreement are as follows:

a. You are responsible for: (i) instituting proper and timely backup procedures for your software and data; (ii) creating timely backup copies of any of your software or data that may be damaged, lost, or corrupted due to our provision of Services; and (iii) using backup copies to restore any of your software or data in the event of any loss of, damage to, or corruption of the operational version of your software or data, even if such damage, loss, or corruption is due to our negligence.

b. If, as a direct result of our negligence in performing the Services, your software or data is damaged, lost, or corrupted, we will assist you in loading the media (e.g., tape) in which you stored the backup copy of your software or data onto the server, mainframe, or other computer system to which your software or data is to be restored. The assistance provided by us may consist of telephone support to your personnel performing the software or data restoration. However, our assistance is conditioned upon TASER being notified by you within 24 hours of you becoming aware that your software or data has been damaged, lost, or corrupted as a direct result of our negligence in performing the Services. However, regardless of any assistance provided by us; (i) we will in no way be liable for the accuracy, completeness, success, or results of your efforts to restore your software or data; (ii) any assistance provided by us under this Section is without warranty, express or implied; and (iii) in no event will we be liable for loss of, damage to, or corruption of your data from any cause.

c. The section does not apply to your data stored on EVIDENCE.com and covered by the EVIDENCE.com Master Service Agreement.

11. Intellectual Property. We own all right, title and interest in all Pre-Existing Works and Documentation. We grant to you, unless otherwise agreed in writing by the parties, a perpetual, non-revocable, royalty-free, non-

exclusive, right and license to use, execute or copy, the Pre-Existing Works provided to you in connection with the delivery of Services and in accordance with this Agreement.

12. Confidentiality. A receiving party may use the disclosing party's Confidential Information only in connection with TASER's performance of the Services under this Agreement. The receiving party will not disclose the end of the Term. The receiving party will take all reasonable measures to avoid disclosure, dissemination or unauthorized use of the disclosing party's Confidential Information, including, at a minimum, those measures taken to protect its own confidential information of a similar nature.

13. Indemnification. Except to the extent caused by the negligent acts or willful misconduct of you, we will indemnify, defend and hold you, your officers, directors, employees, agents, and permitted assigns (each **Agency Indemnitee**) harmless from and against all claims, demands, losses, liabilities, costs, expenses, and reasonable attorneys' fees, arising out of a claim by a third party against an Agency Indemnitee resulting from any negligent act, error or omission, or willful misconduct of TASER under or related to this Agreement.

14. Limitation of Liability. EXCEPT AS OTHERWISE PROVIDED IN THIS AGREEMENT, THE WARRANTIES STATED IN THIS AGREEMENT ARE LIMITED WARRANTIES AND ARE THE ONLY WARRANTIES MADE BY TASER. WE DO NOT MAKE AND HEREBY DISCLAIM, AND YOU EXPRESSLY WAIVE, ALL OTHER WARRANTIES, EXPRESSED OR IMPLIED, EXPRESSLY EXCLUDED ARE ALL WARRANTIES OF MERCHANTABILITY AND FITNESS FOR A PARTICULAR PURPOSE AND ANY OTHER STATUTORY OR COMMON LAW WARRANTY. UNDER NO CIRCUMSTANCES WILL EITHER PARTY HAVE ANY LIABILITY WITH RESPECT TO ITS OBLIGATIONS UNDER THIS AGREEMENT OR OTHERWISE FOR LOSS OF PROFITS, CONSEQUENTIAL, EXEMPLARY, INCIDENTAL OR PUNITIVE DAMAGES, EVEN IF EITHER PARTY HAS BEEN ADVISED OF THE POSSIBILITY OF SUCH DAMAGES. IN ANY EVENT, EXCEPT FOR OBLIGATIONS OF CONFIDENTIALITY AND INDEMNIFICATION SET FORTH IN THIS AGREEMENT, THE LIABILITY OF EITHER PARTY TO THE OTHER PARTY FOR ANY REASON AND UPON ANY CAUSE OF ACTION WHATSOEVER WILL NOT EXCEED THE AMOUNTS ACTUALLY PAID TO TASER UNDER THIS AGREEMENT FOR THE SERVICES IN THE PRIOR 12 MONTHS PRECEDING THE CLAIM. NOTHING IN THIS SECTION LIMITS YOUR OBLIGATIONS UNDER SECTIONS 1 AND 2.

15. Insurance. We will maintain at our own expense and in effect during the Term, insurance coverage as set out below, and will furnish certificates of insurance or self-insurance upon your request:

- a.** Commercial General Liability Insurance with limits of \$1,000,000 per occurrence for Bodily Injury, Property Damage, and Personal and Advertising Injury;
- b.** Workers' Compensation Insurance in compliance with the statutory requirements of the state in which the Services are performed and Employers' Liability Insurance with limits of not less than \$500,000 each Accident and Disease per Employee/Policy Limit; and
- c.** Commercial Automobile Liability Insurance covering hired and non-owned vehicles for which we may be responsible with limits of \$1,000,000 per occurrence Bodily Injury and Property Damage.

16. General.

- a. Non-Discriminatory Employment.** We will not unlawfully discriminate against any individual based on race, color, religion, national origin, age, or condition of disability. We understand and agree that we are bound by and will comply with the nondiscrimination mandates of all Federal, State and local states.
- b. Notifications.** Any notice permitted or required under this Agreement will be deemed to have been given if it is in writing and personally served or delivered, mailed by registered or certified mail (return receipt requested), delivered by a national overnight courier service with confirmed receipt, or sent by email to the parties at the addresses listed in the signature block at the end of this Agreement.
- c. Force Majeure.** We will not be liable for any delay or failure to perform any obligation under this Agreement where the delay or failure results from any cause beyond our reasonable control, including acts of God, labor disputes or other industrial disturbances, systemic electrical, telecommunications, or other utility failures, earthquake, storms or other elements of nature, blockages, embargoes, riots, acts or orders of government, acts of terrorism, or war.
- d. Independent Contractors; Non-Exclusive Rights.** The parties are independent contractors, and neither





party, nor any of their respective affiliates, is an agent of the other for any purpose or has the authority to bind the other. This Agreement does not create a partnership, franchise, joint venture, agency, or fiduciary or employment relationship between the parties.

e. Entire Agreement; Modification. This Agreement, including the Quote, constitutes the entire agreement between the parties and supersedes all prior and contemporaneous agreements, proposals, or representations, written or oral, concerning our provision of the Services. No modification, amendment, or waiver of any provision of this Agreement will be effective unless in writing and signed by both parties. All headings are for reference purposes only and must not affect the interpretation of the Agreement.

f. Severability. This Agreement is contractual and not a mere recital. Sections 1-2, 5-6, 10-15, and 17-18 will continue in force and effect after termination of this Agreement. If any portion of this Agreement is held to be invalid or unenforceable, the remaining portions of this Agreement will remain in full force and effect. Any invalid or unenforceable portions will be interpreted to the effect and intent of the original portion. If such construction is not possible, the invalid or unenforceable portion will be severed from this Agreement but the rest of the Agreement will remain in full force and effect.

g. Waiver. The failure by either party to enforce any provision of this Agreement will not constitute a waiver of the provision nor limit the party's right to enforce the provision at a later time.

h. Voluntary Agreement. This Agreement was negotiated and executed voluntarily and is not the result of duress, fraud, undue influence or any threat of any kind. All parties had the opportunity to consider this Agreement, to consult with counsel, and fully understand the Agreement.

i. No Third-Party Beneficiaries. This Agreement does not create any third-party beneficiary rights in any individual or entity that is not a party to this Agreement.

j. Assignment. Neither party may assign or otherwise transfer this Agreement or any of its rights and obligations under this Agreement without the prior written approval of the other party, except that we may assign or otherwise transfer this Agreement or any of our rights or obligations under this Agreement without the consent of you (a) in connection with a merger, acquisition or sale of all or substantially all of our assets, or (b) to as part of a corporate reorganization. Subject to the foregoing, this Agreement will be binding upon, and inure to the benefit of the parties and their respective successors and assigns.

k. Applicable Law. The validity, construction, interpretation, and administration of this Agreement will be governed by and must be interpreted under the laws of the State in which the Services are performed. In the event of any legal action to enforce the provisions of this Agreement, the successful party in enforcing any provision of this Agreement will be awarded that party's reasonable attorneys' fees and costs.

17. Definitions.

"Confidential Information" means any and all financial, technical, legal, marketing, network and/or other business information, know-how, plans, records, files, file layouts, manuals, documentation, or data (including, but not limited to, computer programs, code systems, applications, analyses, passwords, procedures, output, software sales, personal individual information, and lists compilations). All information communicated during the course of this Agreement, whether written or oral, will be assumed confidential even if it is not specifically noted as such at the time of the disclosure. Both parties acknowledge and agree that a disclosing party's Confidential Information is the proprietary property of the disclosing party and constitutes valuable trade secrets. Nothing in this Agreement will be construed as granting the receiving party any right of use, title, or interest in the disclosing party's Confidential Information.

"Installation Site" means the location(s) where the Products are to be installed.

"Products" means all equipment, software, cloud based services, Product User Documentation and software maintenance releases and updates provided by us under this Agreement.

"Product User Documentation" means either (i) specifications, explanatory or informational materials, whether in paper or electronic form, that relate to the Services provided under this Agreement, or (ii) user manuals, technical manuals, training manuals, specification or other explanatory or informational materials, whether in paper or electronic form, that relate to the Products provided under this Agreement.

"Services" means the professional services provided by us pursuant to this Agreement.

[Document Revised 12-11-2013]

Microsoft is a trademark of the Microsoft group of companies.
© is a trademark of TASER International, Inc., and AXON and TASER are registered trademarks of TASER International, Inc., registered in the U.S. All rights reserved. © 2013 TASER International, Inc.

EXHIBIT “B”

RESOLUTION No. 17-215

A RESOLUTION OF THE MAYOR AND THE CITY COUNCIL OF THE CITY OF DORAL, FLORIDA, PURSUANT TO SECTION 2-322 OF THE CITY CODE OF ORDINANCES, APPROVING THE PURCHASE OF 80 BODY-WORN CAMERAS FROM AXON IN AN AMOUNT NOT TO EXCEED \$116,999.80 VIA CONTRACT NO. 151089, CITY OF TUCSON ARIZONA (NATIONAL INTERGOVERNMENTAL PURCHASING ALLIANCE); AUTHORIZING THE CITY MANAGER TO NEGOTIATE AND ENTER INTO AN AGREEMENT, SUBJECT TO APPROVAL AS TO FORM AND LEGAL SUFFICIENCY BY THE CITY ATTORNEY FOR THE PURCHASE AND TO EXPEND BUDGETED FUNDS IN FURTHERANCE HEREOF; PROVIDING FOR IMPLEMENTATION; AND PROVIDING FOR AN EFFECTIVE DATE

WHEREAS, the Police Department for the City of Doral (the "City") seeks to purchase 80 body-worn cameras from Axon; and

WHEREAS, law enforcement officers have been working to resolve the level of oversight necessary to satisfy review by the courts, the community, or law enforcement command. Video-based evidence of police actions works to satisfy those demands. Officer worn cameras offer a unique, officer's point-of-view at how law enforcement interacts with the community. Mobile video recording was originally envisioned as a tool for the courtroom, but has evolved and proven itself over the last twenty years to be much more, from a training tool to a silent partner who forgets nothing. This law enforcement tool affords officers not only documentation, but also a witness that is not swayed by politics, prejudice, or personal gain. In cases of alleged police misconduct, the technology can work to exonerate officers, corroborate an allegation, or show a suspect's misconduct or illegal activities; and

WHEREAS, body-worn camera supports law enforcement administrators in justifying and defending their officers' actions or reactions in the field, promoting

necessary changes in policies and training, or in taking disciplinary action for officer wrongdoings. Video evidence serves to enhance public trust and by adding another layer of transparency to police actions.

WHEREAS, section 2-322 of the City Code of Ordinance permits the City to enter into agreements entered into by other governmental entities provided that same was competitively solicited and obtained in a manner similar to that prescribed by the City Code; and

WHEREAS, Staff has found advantageous to the City the terms of an agreement between the City of Tucson, Arizona, and Axon, Contract # 151089 (the "Tucson Agreement"), which was competitively entered into in a manner similar to that set forth in Chapter 2, Article V of the City Code; and

WHEREAS, Staff has recommended the City Council authorize the City Manager to negotiate and enter into an agreement with Axon for the purchase of 80 body-worn cameras in an amount not to exceed \$116,999.80 via the Tucson Arizona.

NOW, THEREFORE, BE IT RESOLVED BY THE MAYOR AND CITY COUNCIL OF THE CITY OF DORAL, FLORIDA, AS FOLLOWS:

Section 1. Recitals. The foregoing recitals are confirmed, adopted, and incorporated herein and made a part hereof by this reference.

Section 2. Approval. Pursuant to section 2-322 of the City Code of Ordinance, the purchase from Axon of 80 body-worn cameras, via the Tucson Agreement, attached hereto as Exhibit "A", which is incorporated herein and made a part hereof by this reference, in an amount not to exceed \$116,999.80 is hereby approved. This purchase is funded in account 105.60005.500640- LETF-Treasury for year 1 and

years 2-5 will be funded by the IT Department FY 2018-2019 in the amount not to exceed \$110,464.00.

Section 3. Authorization. The City Manager is hereby authorized to enter into an agreement and other contractual documents, subject to approval as to form and legal sufficiency by the City Attorney, as may be necessary to procure the body-worn cameras via the Tucson Agreement, and to expend funds, in furtherance thereof.

Section 4. Implementation. The City Manager and the City Attorney are hereby authorized to take such further action as may be necessary to implement the purpose and provisions of this Resolution.

Section 5. Effective Date. This Resolution shall become effective immediately upon its adoption.

The foregoing Resolution was offered by Councilmember Cabrera who moved its adoption. The motion was seconded by Councilmember Mariaca and upon being put to a vote, the vote was as follows:

Mayor Juan Carlos Bermudez	Yes
Vice Mayor Ana Maria Rodriguez	Not Present at Time of the Vote
Councilman Pete Cabrera	Yes
Councilwoman Christi Fraga	Not Present at Time of the Vote
Councilwoman Claudia Mariaca	Yes

PASSED AND ADOPTED this 13 day of December, 2017.



JUAN CARLOS BERMUDEZ, MAYOR

ATTEST:



CONNIE DIAZ, CMC
CITY CLERK

APPROVED AS TO FORM AND LEGAL SUFFICIENCY
FOR THE USE AND RELIANCE OF THE CITY OF DORAL ONLY:



WEISS, SEROTA, HELFMAN, COLE & BIERMAN, P.L.
CITY ATTORNEY

EXHIBIT “C”

Non-Binding Budgetary Estimate



Axon Enterprise, Inc.
 17800 N 85th St.
 Scottsdale, Arizona 85255
 United States
 VAT: 86-0741227
 Domestic: (800) 978-2737
 International: +1.800.978.2737

Q-325550-44399.531BR

Issued: 07/22/2021

➔ Quote Expiration: 08/15/2021

Account Number: 210651

Payment Terms: N30
 Delivery Method: Fedex - Ground

SHIP TO	BILL TO
Delivery-6100 NW 99th Ave 6100 NW 99th Ave Doral, FL 33178-2738 USA	Doral Police Dept. - FL 8401 NW 53rd Ter Miami, FL 33166-4517 USA Email:

SALES REPRESENTATIVE	PRIMARY CONTACT
Brendan Rome Phone: Email: brome@axon.com Fax:	Phone: (305) 593-6699 Email: carlos.delauz@doralpd.com Fax: (786) 871-1501

PAYMENT PLAN		
PLAN NAME	INVOICE DATE	AMOUNT DUE
Year 1	Sep, 2021	\$17,576.99
Year 2	Sep, 2022	\$17,577.00

Quote Details

Bundle Summary				
Item	Description	QTY	Average Cost Per Year	Cost Per User Per Month
BWCUwTAP	BWC Unlimited with TAP	11	\$12,011.48	\$91.00
AB3C	AB3 Camera Bundle	11	\$3,773.50	\$28.59
AB3MBD	AB3 Multi Bay Dock Bundle	2	\$1,467.39	\$61.14

Bundle: BWC Unlimited with TAP Quantity: 11 Start: 10/1/2021 End: 10/14/2023 Total: 24474.99 USD				
Category	Item	Description	Requested Ship Date	
Camera Warranty	80464	EXT WARRANTY, CAMERA (TAP)	09/01/2021	
E.com License	73746	PROFESSIONAL EVIDENCE.COM LICENSE (Formerly SKU 73746)		
Warranty	80465	EXT WARRANTY, MULTI-BAY DOCK (TAP)	09/01/2021	
Multi-bay Dock Refresh 1	73689	MULTI-BAY BWC DOCK 1ST REFRESH	03/01/2024	
Camera Refresh 1 with Spares	73309	AXON CAMERA REFRESH ONE	03/01/2024	
Multi-bay Dock Refresh 2	73688	MULTI-BAY BWC DOCK 2ND REFRESH	09/01/2026	
Device Storage	73686	EVIDENCE.COM UNLIMITED AXON DEVICE STORAGE		
Camera Refresh 2 with Spares	73310	AXON CAMERA REFRESH TWO	09/01/2026	
A La Carte Storage	73683	10 GB EVIDENCE.COM A-LA-CART STORAGE		

Bundle: AB3 Camera Bundle Quantity: 11 Start: 10/1/2021 End: 10/14/2023 Total: 7689 USD				
Category	Item	Description	Requested Ship Date	
Camera	73202	AXON BODY 3 - NA10	09/01/2021	
Camera Mount	74028	WING CLIP MOUNT, AXON RAPIDLOCK	09/01/2021	
USB	11534	USB-C to USB-A CABLE FOR AB3 OR FLEX 2	09/01/2021	

Bundle: AB3 Multi Bay Dock Bundle Quantity: 2 Start: 10/1/2021 End: 10/14/2023 Total: 2990 USD				
Category	Item	Description	Requested Ship Date	
Dock	74210	AXON BODY 3 - 8 BAY DOCK	09/01/2021	
Power Cord	71019	NORTH AMER POWER CORD FOR AB3 8-BAY, AB2 1-BAY / 6-BAY DOCK	09/01/2021	

Hardware				
Requested Ship Date	Item	Description	QTY	

Non-Binding Budgetary Estimate

09/01/2021	80464	EXT WARRANTY, CAMERA (TAP)	11
09/01/2021	80465	EXT WARRANTY, MULTI-BAY DOCK (TAP)	2
09/01/2021	73202	AXON BODY 3 - NA10	11
09/01/2021	71019	NORTH AMER POWER CORD FOR AB3 8-BAY, AB2 1-BAY / 6-BAY DOCK	2
09/01/2021	11534	USB-C to USB-A CABLE FOR AB3 OR FLEX 2	11
09/01/2021	74210	AXON BODY 3 - 8 BAY DOCK	2
09/01/2021	74028	WING CLIP MOUNT, AXON RAPIDLOCK	11

This Rough Order of Magnitude estimate is being provided for budgetary and planning purposes only. It is non-binding and is not considered a contractable offer for sale of Axon goods or services.

Tax is estimated based on rates applicable at date of quote and subject to change at time of invoicing. If a tax exemption certificate should be applied, please submit prior to invoicing.

